

 **2024.01**  
CATALOGUE

the toolmaker  
**GOVONI**<sup>®</sup>

*...just blue, just perfect!*



SPECIAL TOOLS

the toolmaker  
**GOVONI**<sup>®</sup>  
*...just blue, just perfect!*





Dear business partners and friends!

Since its foundation in 1977, GOVONI has become one of the leading manufacturers of special tools for the automotive industry. Continuously expanding his position through permanent and focused investment in technological and product innovation, keys factors of GOVONI constant growth and success.

Thanks to this new catalogue and the further expanded range of product, we have reached another important milestone in GOVONI's 45-year history!

You can find over 700 single products and solutions divided into six main product area such as:

Suspensions, Engine, Hydraulic cylinders, Garage workshop, Truck.

More than 100 brand new products make this new catalogue extremely valuable. In addition, we have recon-figured and updated the layout of this catalogue. The products are divided into sections characterized by different colours per each family, so they are easier to find.

There is more detailed than ever before, on the product with images and applications illustrations. You will find out also our new coding system, short, easy and simple to remember! Finally, you may pay special attention to our new GOBOX packing solutions which is unique of its kind, robust, modular, flexible and customizable!

For GOVONI, selling excellent products it's not enough.

All the knowhow obtained so far have made Govoni one of the best operative tools manufacturers in the market, with customers spread worldwide in over 64 countries ... and It's just the beginning!

Our passion is made of intelligent, reliable and durable products for professional users who understand that solution and quality make the difference.

*...just blue, just perfect!*

# MADE IN ITALY

From the heart of Italy and the lovely region of Bologna.  
In the middle of the automotive valley where dream vehicles are manufactured.



**This is our home!**



#### HEADQUARTER

Via degli Orsi 97  
40014 Crevalcore (BO)  
Italy

#### OUR CONTACTS

tel +39 .0. 51 982688  
+39 .0. 51 980798  
e-mail [info@govoni.it](mailto:info@govoni.it)



## OUR ESTATES



**PRODUCTION PLANT 1**  
Crevalcore, Italia



**PRODUCTION PLANT 2**  
Crevalcore, Italia



**DISTRIBUTION CENTRE**  
Crevalcore, Italia



**DEVELOPMENT AND TRAINING CENTER**  
Leipzig, Deutschland



**DISTRIBUTION CENTRE**  
Barcelona, España

# TRAINING CENTRE



Welcome to the **blue!** Our new Development and Training Center – **Bologna**/Emilia Romagna.





HERE WE ARE

# TRAINING CENTRE



Welcome to the **blue!** Our new Development and Training Center – **Leipzig**/Saxony.



Book your **blue experience**, become a car repair expert!



**GOVONI Srl**

Development and Training Center  
Saalfelder Strasse 3  
04179 Leipzig | GERMANY |

GERMANY.SAXONY.LEIPZIG

WWW.THETOOLMAKER.COM

# AT EXPOS IN EUROPE



**automechanika**  
FRANKFURT



**autopromotec**  
**mórtotec**  
MADRID





ON TOUR

# ALL OVER ON THE ROAD



# SECTION

## **G** CHASSIS & SUSPENSIONS

**1-50**

<b>HUBS AND BEARINGS</b>	2-27
<b>SILENT BLOCKS AND SWIVELING ARMS</b>	28-39
<b>SHOCK ABSORBER</b>	40-47
<b>BRAKES</b>	48
<b>TIRES</b>	49-50

## **G** ENGINE

**51-182**

<b>INJECTORS AND GLOW PLUGS</b>	52-92
<b>ENGINE AND DISTRIBUTION</b>	93-106
<b>CLUTCH</b>	107-110
<b>TRANSMISSION GEARBOX</b>	111-115
<b>OIL SUMP AND FILTERS</b>	116-130
<b>RADIATOR AND AIR CONDITIONING</b>	131-133
<b>EXHAUST SYSTEM</b>	134-139
<b>CYLINDER HEAD AND ENGINE BLOCK</b>	140-148
<b>TIMING TOOLS</b>	149-182



# CATALOGUE



## **G** HYDRAULIC CYLINDERS

**183-192**

**CYLINDERS**

184-188

**PUMPS**

189-190

**CONNECTIONS**

191-192

## **G** BODY SHOP

**193-206**

**DOORS**

194-197

**GLASS**

198-199

**SHEET METAL**

200-203

**SYSTEM STACKING CABINET FOR GOBOX CASE**

204-206

## **G** TRUCK

**207-221**

**SILENT BLOCKS**

208-209

**HUBS**

210-215

**ENGINE**

216-218

**BRAKES**

219-221

the toolmaker  
**GOVONI**<sup>®</sup>  
*...just blue, just perfect!*

# CHASSIS & SUSPENSIONS

<b>HUBS AND BEARINGS</b>	<b>2-27</b>
<b>SILENT BLOCKS AND SWIVELING ARMS</b>	<b>28-39</b>
<b>SHOCK ABSORBER</b>	<b>40-47</b>
<b>BRAKES</b>	<b>48</b>
<b>TIRES</b>	<b>49-50</b>



## EXTRACTION SET DRIVE SHAFTS AND CV JOINTS FOR HUBS CARS



- For pressing out seized and bonded drive shafts and also, with the optional Govoni slide hammer **GO520** or **GO530**, for removing the wheel hub.
- Considerable time savings - no damage to the thread - wheel bearing is not damaged - Optimised hole pitch for maximum coverage of models within the market.
- Suitable for 2, 3, 4, 5 and 6-hole bolt pitch on hubs with stud bolts and wheel bolts
- For use on all vehicles ranging from passenger cars to transporters, and particularly for extremely firmly anchored drive shafts on VW Group, Mazda, Ford, BMW, Renault and Peugeot.
- When extreme force is required, can also be used with Govoni 16-ton mechdraulics (**GO1016** optional).

### Technical data

- Slotted mounting hole: M12 and M14
- Working range:  
M12: Ø96-138 mm  
M14: Ø98-136 mm



### INCLUDED:

Lubricating grease to be used with threaded bars, nuts etc...

### Components

1 x extractor with mounting thread 1-1/2"-16G  
1 x reducing adapter ring for mechanical spindle, 1-1/2"-16G x M22x2  
1 x mechanical spindle, M22x2

1 x pulling flange, 96-142 mm for 3, 4, 5 and 6-hole bolt hub, for M12/M14 bolts  
5 x conical washers  
1 x lubricating grease

### Example of application



Pushing out the drive shaft, mechanically using the tool set



Pulling out the wheel hub, using a slide hammer, optional code **GO520**



Pushing out the drive shaft, using a 16-Ton Mechadraulic-Spindle, optional code **GO1016**



Pushing out the drive shaft, mechanically on the work bench

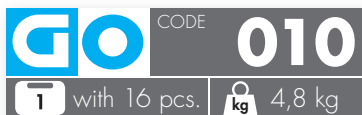

**+ 16TON MECHADRAULIC-SPINDLE ADAPTOR KIT**

**Technical data**

- Force: 16 ton
- Dimensions: Ø38x225x345 mm
- Driving torque: 38 Nm
- Receiving thread: 1-1/2 inch x 16 tpi
- Stroke: 20 mm
- Weight: 1,7 kg



- Due to the mechanical properties, shape and size, the Govoni Mechadraulic-Spindle is optimally suited for use in the automotive sector: removal and installation of wheel hubs, drive shafts, supporting joints, tie rod heads, pitman arms, silent bearings etc.



**+ INTRODUCTION SET DRIVE SHAFTS AND CV JOINTS**



- Use this kit if the profile of the seat of the drive shaft's spline has a high degree of adjustment with respect to the profile of the seat of the hub's spline.
- The adapters in this kit can be used both on drive shafts secured with nuts (of commercial use) and those secured with bolts (VW/Audi for example).
- This set is also suitable for fitting the hub.
- Use this kit with the Govoni code **GO010** and **GO012**.

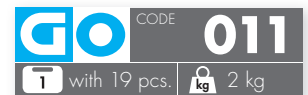

**G RING PLIERS AND 4 SHELLS**

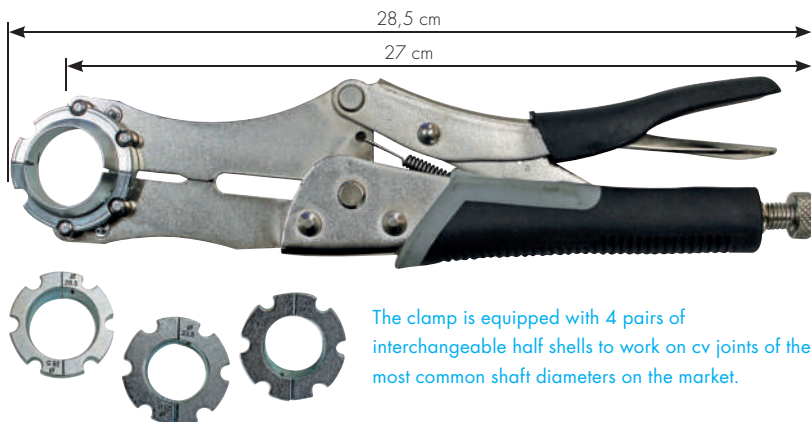

The clamp is equipped with 4 pairs of interchangeable half shells to work on cv joints of the most common shaft diameters on the market.

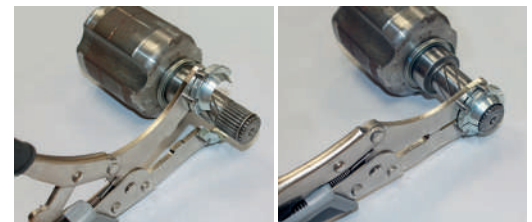

Clamps come down automatically when the joint opens. Ideal for saving the axle shaft without risking damage and having to replace it completely.

**Components**

- 1 x Pliers
- 2 x Ø23.8 mm half shell
- 2 x Ø24.6 mm half shell
- 2 x Ø26.9 mm half shell
- 2 x Ø28.5 mm half shell

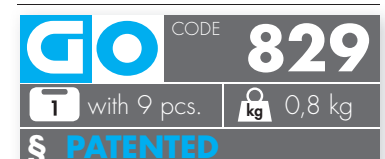

- Locking pliers supplied with 4 sets of interchangeable clamps for tightening the snap ring on the transmission shaft to reinstall the seal (bowl) on the transmission when using the SNR OBK (Outer Boot Kit) and OJK (Outer Joint Kit) types.
- The rush compressed by the conical shell will be released when hitting the bowl.
- This pliers ensure a mounting without risk of damage of the rush (clips), or the teeth when inserting the bowl on the transmission shaft



## PULL ROD/EXTENSION SET UNIVERSAL



Drive shaft  
extraction from hub

### Components

5 x spacers kit for hub flange M12x1.25

5 x spacers kit for hub flange M12x1.50

5 x spacers kit for hub flange M14x1.50

- Useful addition to Govoni's **GO010** kit for the removal of CV joints.
- This kit ensures a strong flange connection with the hub and is also suitable for systems with wheel nuts and/or bolts.
- The user is not bound to the diameter of the hub edge since the hub's flange is placed 80 mm or 90 mm in front of the hub.

**GO** CODE **070**  
1 with 25 pcs. 1 kg 5,2 kg

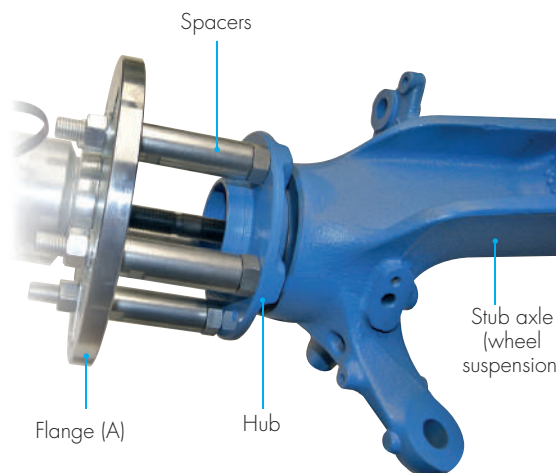

**GO** CODE **071**  
1 with 5 pcs. 1 kg 1,8 kg

**M12X1.25**

### Components

1 x spacers kit M12x1.25 L = 80 mm

**GO** CODE **073**  
1 with 5 pcs. 1 kg 1,8 kg

**M14X1.25**

### Components

1 x spacers kit M14x1.25 L = 80 mm

**GO** CODE **072**  
1 with 5 pcs. 1 kg 1,8 kg

**M12X1.5**

### Components

1 x spacers kit M12x1.5 L = 80 mm

**GO** CODE **074**  
1 with 5 pcs. 1 kg 1,8 kg

**M14X1.5**

### Components

1 x spacers kit M14x1.5 L = 80 mm





## CV JOINTS INTRODUCTION KIT CAR, UNIVERSAL



- Tool kit for maintenance intervention on the drive shaft. Especially for vehicles with high fitting accuracy of the wedge taper profile of the drive shaft in relation to the wheel hub wedge taper profile.
- 10 tension sleeves and 2 tension bolts ensure maximum coverage of markets and models!
- For nut-secured (commonly used) and bolt-secured (e. g. VW/Audi) drive shafts.
- The slide hammer can be used to remove the outer drive shaft joints even when installed.
- Particularly important in the act of replacing the original rubber or thermoplastic sleeves. In order to complete the set, a 3-piece special pliers set, for the special circlips without eyelet, is included.

### Application

- 1 Inserting the drive shafts into the wheel hub
- 2 Disconnecting the drive shaft coupling
- 3 Fitting the drive shaft coupling
- 4 Circlips disassembly and assembly on drive shafts

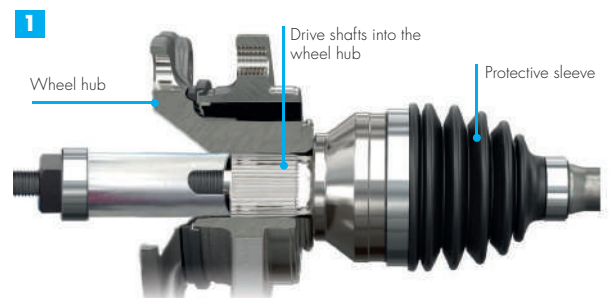

**GO** CODE **013**  
1 with 24 pcs. **kg** 6,8 kg





## EXTRACTION/INTRODUCTION SET DRIVE SHAFTS AND CV JOINTS FOR HUBS CARS



Example application with Mechadraulic-Spindle (optional)

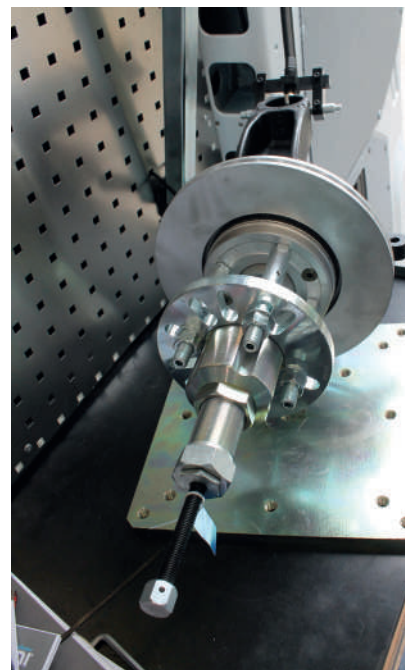

- Use the tools contained in the kit for proper assembly and disassembly procedures. Furthermore, components such as wheel bearings, silent blocks and ball joints, for example, will be preserved.
- The adapters contained in the kit allow the use of CV joints, secured both by nuts (usually the common ones) and bolts (e.g.: Gruppo VW/Audi).
- Optimized hole pitch for maximum coverage of models within the market (suitable for 2, 3, 4, 5 and 6-hole bolt pitch on hubs mounted on passenger cars).
- When an extreme forced is required, max till 16 ton, use Govoni Mechadraulic-Spindle **GO1016** (optional).

### Application 1

Mechanical removal of the CV joint

### Application 2

Insertion of the CV joint

### Application 3

Insertion/disconnection of the CV joint with 1,5 kg slide hammer (1,5 kg slide hammer not supplied GO406)

### Application 4

Removal of the wheel hubs/floating axles and brake drums with a 9 kg slide hammer (9 kg slide hammer not supplied GO520 or GO530)

### Application 5

Assembly of the wheel hubs

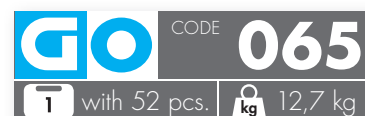



Example of application

1



2



3



4

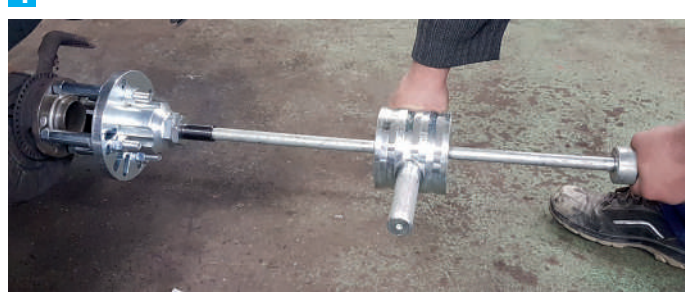

5



**+ 16TON MECHADRAULIC-SPINDLE ADAPTOR KIT**



**+ PULL ROD/EXTENSION SET M14X1.25**

**Components**

1 x spacers kit M14x1.25 L = 80 mm



**GO** CODE **073**  
1 with 5 pcs. **kg** 1,8 kg

**Technical data**

- Force: 16 ton
- Dimensions: Ø38x225x345 mm
- Driving torque: 38 Nm
- Receiving thread: 1-1/2 inch x 16 tpi
- Stroke: 20 mm
- Weight: 1,7 kg

**GO** CODE **1016**  
1 with 7 pcs. **kg** 2,2 kg



## EXTRACTION SET DRIVE SHAFTS AND CV JOINTS FOR HUBS COMMERCIAL VEHICLES



- Aimed to remove locked and tighten drive shafts, and by using the Govoni slide hammer (**GO520** or **GO530**), also wheel hubs.
- Considerable time savings - no damage to the thread - wheel bearing is not damaged.
- Optimized hole pitch for maximum coverage of models within the market (suitable for 2, 3, 4, 5 and 6-hole bolt pitch on hubs mounted on passenger cars and commercial vehicles).
- When an extreme forced is required, max till 17 ton, use Govoni Mechadraulic-Spindle **GO1016** (optional) or hydraulic cylinder **GO1061** (optional).

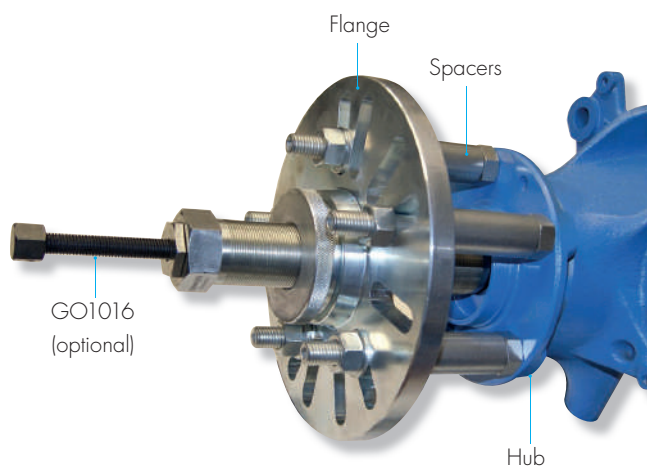
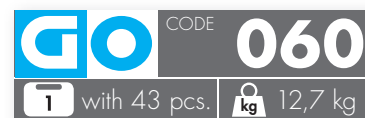

### + 16TON MECHADRAULIC-SPINDLE ADAPTOR KIT



#### Technical data

- For nut and bolt systems: M12/M14/M16/M18
- Working range: Ø115-186mm
- Slotted hole connection: Ø14 mm
- Tension bolt length: 80 mm



#### Technical data

- Force: 16 ton
- Dimensions: Ø38x225x345 mm
- Driving torque: 38 Nm
- Receiving thread: 1-1/2 inch x 16 tpi
- Stroke: 20 mm
- Weight: 1,7 kg







## WHEEL BEARING TOOL SET UNIVERSAL



- Complete set for mounting and dismounting wheel bearing and for assembling hubs.
- The large number of pressure bushes and centering washers allows the product to cover a wide range of models and applications.
- Safety and accurate centering of all the components during working operations.
- Ideal to be used also with a press machine suitable for wheel bearing, silent bearings, bushes, washers, hubs etc.
- Installation without damages thanks to the special design of the components.
- **1** Bearing installation = pressure on the bearing outside ring
- **2** Hub installation = pressure on the bearing inner ring.
- Use with screw M20 (supplied) or with Govoni hydraulic cylinder 17 ton code **GO1061** (Long spindle required).

### Application

For universal use on vehicles ranging from passenger cars to transporters

### Components

1 x spindle M20 with hex drive, size 24, L= 300 mm
1 x pressure nut M20 with hex drive, size 24, L= 50 mm
1 x pressure bearing
1 x drive unit with mount for centring sleeve
5 x pressure sleeves, internal Ø 70, 75, 80, 85, 90 mm, with viewing window

1 x step tread for pressure sleeve, Ø 70, 75, 80 mm
1 x step tread for pressure sleeve, Ø 85, 90 mm
14 x pressure plates, Ø 60, 62, 64, 66, 68, 70, 72, 74, 76, 78, 80, 82, 84, 85 mm
12 x pressure/centring sleeves, external Ø 30, 34, 35, 37, 38, 39, 40, 41, 42, 43, 45, 48 mm
1 x pressure piece for workshop press, Ø 50 mm
1 x lubricating grease



### INCLUDED:

Lubricating grease to be used with threaded bars, nuts etc...



### INCLUDED:

Modular system

**GO** CODE **015**  
1 with 39 pcs. **kg** 13,2

**Example of application**

**1** Bearing installation



Bearing removal



**2** Hub installation



**+ 17T HYDRAULIC CYLINDER  
43 MM, STEEL**



**Technical data**

- Dimensions: Ø90x155 mm
- Pressure: max. 700 Bar
- Hole: Ø20 mm
- Connection: 3/8" -18 NPT
- Outside connection thread: 2" 3/4-16 UN

**GLOCK**  
HYDRAULIC  
**GO** CODE **1017**  
T with 1 pcs. kg 4 kg

**GOQUICK**  
HYDRAULIC  
**GO** CODE **1017Q**  
T with 1 pcs. kg 4 kg

**+ 17T HYDRAULIC CYLINDER  
43 MM, ALUMINIUM**



**Technical data**

- Dimensions: Ø90x155 mm
- Pressure: max. 700 Bar
- Connection: 3/8" -18 NPT
- Outside connection thread: 2" 3/4-16 UN
- Adaptors: M10/M12/M14/M16 M18

**GLOCK**  
HYDRAULIC  
**GO** CODE **1061**  
T with 7 pcs. kg 2,2 kg  
§ **PATENTED**

**GOQUICK**  
HYDRAULIC  
**GO** CODE **1061Q**  
T with 7 pcs. kg 2,2 kg  
§ **PATENTED**

**+ SPINDLE M20**



**Components**

- 1 x spindle M20x1.5 - L=500 mm - Hex. 15
- 2 x nut M20x1.5 - L=50 - Hex. 30
- 2 x washer Ø37x21x3 mm

**Application**

To be used with GO015, GO017

**GO** CODE **016**  
T with 5 pcs. kg 1,6 kg

**+ SPINDLE M24**



**Components**

- 1 x spindle M24x2 - L=500 mm - Hex. 17
- 1 x nut M24x2 - L=35 - Hex. 36
- 1 x washer Ø44x25x4

**Application**

To be used with GO040

**GO** CODE **041**  
T with 3 pcs. kg 1,6 kg



## UNIVERSAL SUPPORTING TOOL FOR THE REMOVAL AND INSERTION OF BEARINGS



- Modular tool set for removing and inserting bearings and for inserting hubs.
- Suitable when hub and bearing are not integrated but separated. This tool set can also be used in combination with the removal and insertion tool set of hubs/bearings, silent blocks, etc.
- Manual application with M20 screw (included in the tool set) or with 17-ton hydraulic cylinder - 43-mm stroke **GO1017** (cylinder not included in the tool set - long screw is required).



Slot for monitoring  
progress of operations

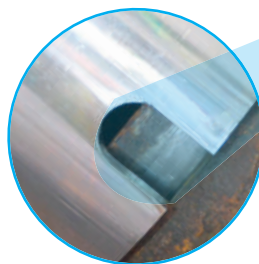

**GO** CODE **018**  
with 22 pcs. **kg** 13 kg







## WHEEL BEARING SET XXL BASIC FROM Ø85.5MM TO Ø99 MM



- Set for the disassembly and assembly OF Ø 85 mm wheel bearings and for the installation of the wheel hub directly on the vehicle or with the help of a workshop press.
- It is an addition to the **GO015** wheel bearing kit and is designed to house the components of both sets. (also available as a complete set **GO018** incl. chuck).

**Fig.1** Bearing installation = pressure on the bearing outer ring

**Fig.2** Wheel hub installation = pressure on the bearing inner ring.

**3-part pressure element**  
This allows an exact fit to the inner bearing - Ø A and outer - Ø B!

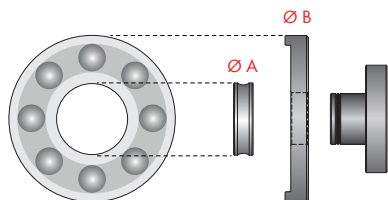

**PLUS:**  
49 possible combinations!



**UNIVERSAL:**  
to cover a wide RANGE OF VEHICLES!

workbench or directly on the vehicle



bearing installation / workshop press

**Fig. 1**



workbench or directly on the vehicle

**Fig. 2**

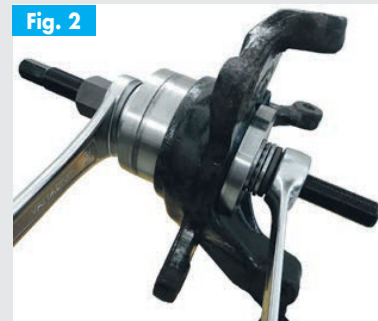

**GO** CODE **019**  
1 with 23 pcs. kg 9,2 kg

**Application**

Ideal for wheel hubs and bearings on large cars.  
It can be used on silentblocks / bushings / sleeves etc.

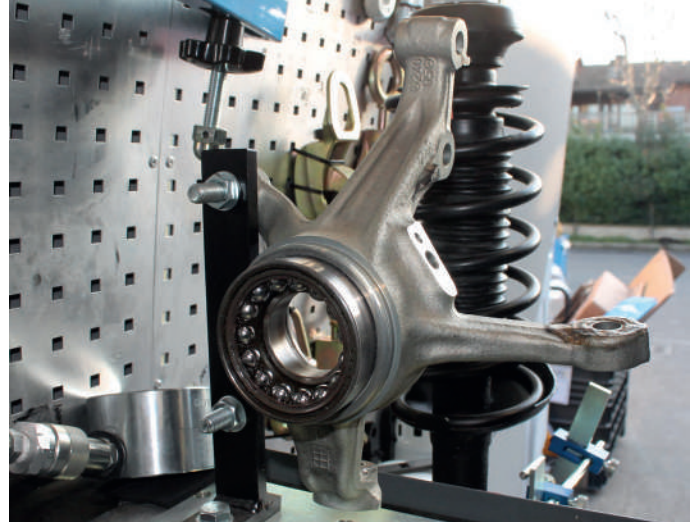
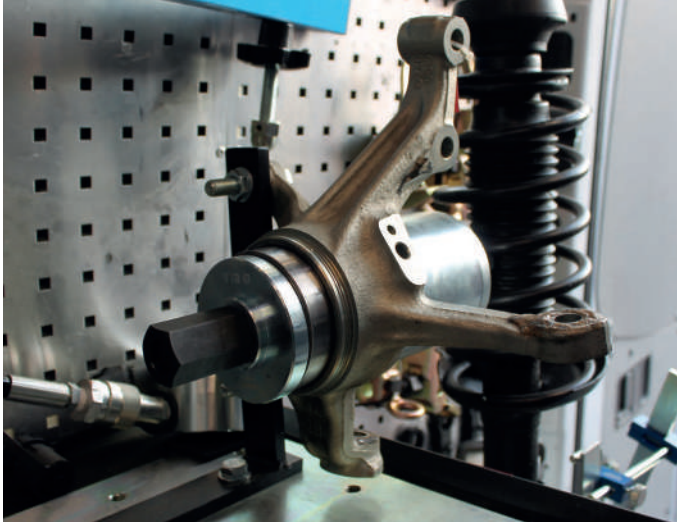

**Components**

- 7 x bearing pressure ring Ø85.5/Ø87.5/Ø89.5/Ø91.5/Ø95.5/Ø97.5/  
Ø99 mm

---

- 7 x bearing centring ring Ø44.5/Ø48.5/Ø49.5/Ø50.5/Ø53.5/Ø54.5/  
Ø57.5 mm

---

- 1 x pressure ring for press Ø43 mm

---

- 2 x support Ø95/Ø100 mm

- 1 x centring device for supports Ø95-Ø100

---

- 1 x pressure plate for press

---

- 1 x guide for bearing

---

- 1 x M20x1.5 screw L=300

---

- 1 x nut + OR + bearing

---

- 1 x M20x1.5 L=50 nut



**CLEANING SET FOR WHEEL BEARING HOUSINGS**

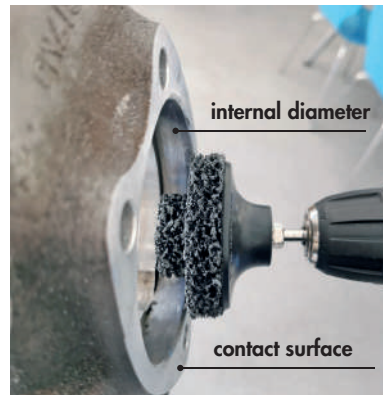

- The flat cleaning disc cleans the contact surface, while the stepped disc also cleans the internal diameter of the housing in a single operation.
- The discs remove corrosion or other residues from the steel and aluminium axle housings before proceeding with the installation of a new bearing.



**Application**

the circular discs (2pcs), mounted on the special backing pad supplied, can be used with cordless screwdrivers and lightweight drills with MAX 10,000 RPM.



CODE

**049**

1 with 3 pcs.

kg 0,23 kg



## EXTRACTION SET FOR BEARING INNER NUTS, FOR Ø 35 - Ø 55 MM CAR, UNIVERSAL



- This set allows to extract easily and quickly the inner ring of the bearings without damages.
- Usually extracting the hubs, the rings remain in their seats and without a special tool is not possible to remove them.
- This set can be use for the replacement of the rings from Ø 35 to Ø 55 mm.
- The kit include the bushing for mounting Mechadraulic-Spindle optional **GO1016** (not included).

### Components

- 2 x spanners Ø 59.5/83.0 mm
- 1 x external part for body extractor
- 1 x body extractor 1-1/2"-16G
- 1 x adapter for screw 1-1/2"-16G x M22x2
- 1 x basic unit including spindle M22 with pressure cone
- 1 x lubricating grease

CLAMPING SLEEVE SIZE			
323016014	323016004	323016003	323016005
Ø35-40 mm	Ø40-45 mm	Ø45-51 mm	Ø50-55 mm

**Application with spindle screw**  
(included)



**Example of application with GO1016** (not included)



### Application

VW, Audi, BMW, Ford, FCA, Mercedes, Opel, Renault, Peugeot, Nissan, Citroën, Volvo etc.



### INCLUDED:

Lubricating grease to be used with threaded bars, nuts etc...



**GO** CODE **021**  
1 with 11 pcs. 5 kg



## CLAMPING SLEEVE Ø55 - Ø61 MM



- This set can be use for the replacement of the rings from Ø 55 to Ø 61 mm.

### PLIERS FUNCTION



**GO** CODE **022**  
1 with 1 pcs. 0,27 kg





## WHEEL BEARING INNER RING EXTRACTOR SET, FOR Ø60 - 80 MM **UNIVERSAL**



### **INCLUDED:**

Lubricating grease to be used with threaded bars, nuts etc...

- To remove the bearing inner rings which usually remain on the wheel hub when changing the wheel bearings.
- New design for large bearing rings, which can not be removed with the kit **GO021**.
- Unique gripper principle is effective even when the bearing ring is flush with the hub.
- The bearing ring is held firmly on the entire circumference and removed without tilting.

### **Components**

- 1 x basic unit including spindle M22 and pressure cone, 5 pcs.
- 1 x clamping sleeve Gr. 1 Ø60 - 64 mm e.g. for Mercedes W201 – W202 – W203 – W210 – W214 / BMW / Peugeot
- 1 x clamping sleeve Gr. 2 Ø64 - 68 mm e.g. for Mercedes W163 – W140 – W169 – W211 – W220 – W245 – W124T
- 1 x clamping sleeve Gr. 3 Ø68 - 72 mm e.g. for VW Touareg / Porsche Cayenne
- 1 x clamping sleeve Gr. 4 Ø72 - 76 mm e.g. for Mercedes ML164 – ML166 / Renault Master – Opel Movano – Nissan NV400 (2010–)
- 1 x clamping sleeve Gr. 5 Ø76 - 80 mm e.g. for VW-Audi with bolted wheel bearing
- 2 x spanner
- 1 x lubricating grease

### **Application**

Universally applicable to cars and vans as well as for bearing rings in general (e.g. gears etc.)

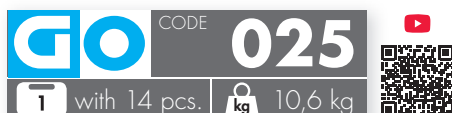



## TOOL SET FOR COMPACT WHEEL HUB/ BEARING UNIT, MECHANICAL **MAX 12 TON**

**UPGRADE**

∅ 62 ∅ 66 ∅ 68 ∅ 72 ∅ 78 ∅ 82 ∅ 85



Slot for monitoring progress of operations

### Example of application

#### Removal

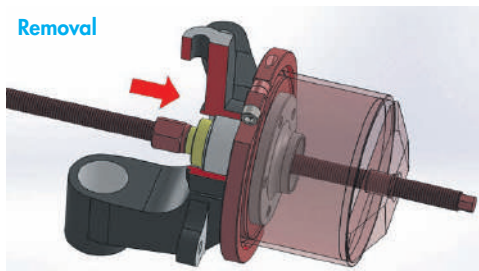

#### Installation

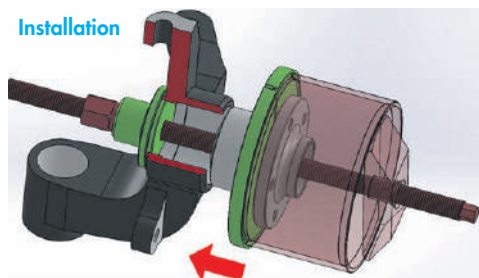

- Full assortment for correct removal and installation of compact bearing hub units on vehicles ranging from passenger cars to transporters.
- The perfect set for all current bearing units with diameters of 62 - 85 mm.
- Includes a threaded spindle M20 and nut, and a counter-pressure nut with pressure bearing for mechanical operation. For frequent use with large bearing units or badly corroded bearings, we recommend the optional 12-tonne hydraulics (optional).
- The special half shells grip behind the wheel hub during installation and press on the snap ring located directly on the bearing outer ring.
- This prevents damage to the bearing and allows the snap ring to engage evenly.
- The repair work can be performed directly on the vehicle.
- Easy to use - significant time savings - no damage to the bearing.

**GO** CODE **030**  
 with 34 pcs. 16 kg  
 § **PATENTED**

**+** **INCLUDED:**  
 Lubricating grease to be used with threaded bars, nuts etc...

### Example hub/bearing extraction application



### Application

Ø 62	Audi A2 - VW Lupo
Ø 66	Seat Cordoba 4 - Ibiza 3 (dal 2005) Skoda Fabia (6Y) - VW Fox (ABS)/Polo 7, 8 (9N)
Ø 68	Citroën C3 -C4 (measure bearing diameter first) - Renault (Kadjar - Megane)
Ø 72	Audi A1/A2 (ABS) - Seat Cordoba 4/Ibiza 3, 4 (to 2005) - Skoda Fabia(6Y)/Fabia 2 (5J)/Roomster; VW Fox/Polo 7, 8 (9N)
Ø 78	Volvo C30/C70CC/S40 2/V50 - Ford C-Max/Focus 2 - Mazda 3 (BK)
Ø 82	VW Touareg/Porsche Cayenne
Ø 85	VW T5 (VA + HA)

### Sizes and assignment of half shell sets (HSS)

#### INSTALLATION:

- 1 x HSS size 1 for Ø 62 mm
- 1 x HSS size 2 for Ø 66, 68 mm
- 1 x HSS size 3 for Ø 72, 75, 78 mm
- 1 x HSS size 4 for Ø 82, 85 mm

#### REMOVAL:

- 1 x HSS for Ø 62, 66, 68, 72, 75, 78, 82, 85 mm

## + 12T HYDRAULIC CYLINDER 8 MM, STEEL



### Technical data

- Dimensions: Ø80x55 mm
- Pressure: max. 700 Bar
- Hole: Ø21.5 mm
- Connection: 3/8" -18 NPT

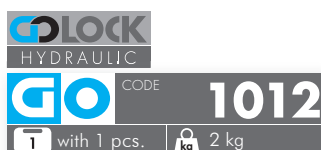

## + 12T HYDRAULIC CYLINDER 43 MM, ALUMINIUM



### Technical data

- Dimensions: Ø90x155 mm
- Pressure: max. 700 Bar
- Hole: Ø20 mm
- Connection: 3/8" -18 NPT
- Mounting thread: 2" 3/4-16 UN
- Adaptors: M10/M12/M14/M16/M18

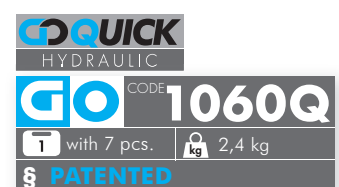
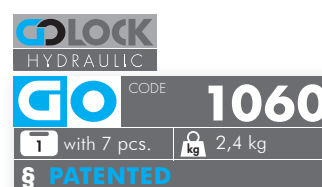



# G TOOL SET FOR REMOVING COMPACT WHEEL HUB/ BEARING UNIT, MECHANICAL MAX 12 TON

**UPGRADE**

Ø62 Ø66 Ø68 Ø72 Ø78 Ø82 Ø85

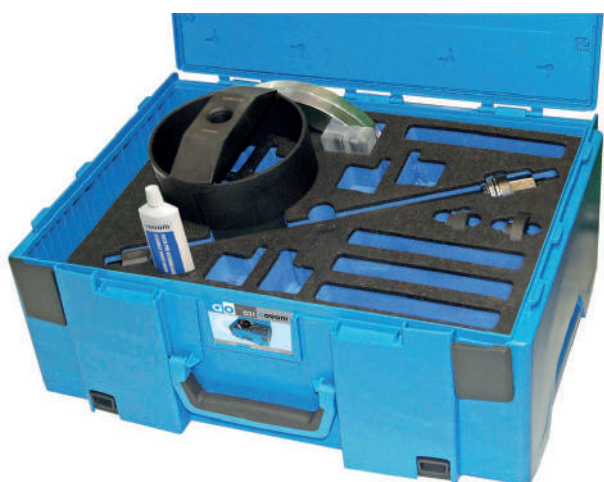

### Example of application

Installation

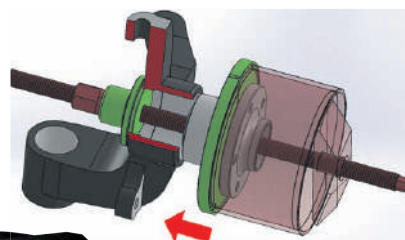

Slot for monitoring progress of operations

- The set contains tools for removing bearing units with diameters of 62-85 mm. This set can be expanded as required with the corresponding half shell sets for installation.
- The repair work can be performed directly on the vehicle.
- Easy to use - significant time savings - no damage to the bearing

**GO** CODE **031**  
with 23 pcs. 12 kg  
§ **PATENTED**

### Application

Disassembly: it can work on bearings with an external from Ø62 mm up to Ø85 mm.

### Sizes and applications of the half shell set (HSS)

Half shell removal:

1 x HSS for Ø 62, 66, 68, 72, 75, 78, 82, 85 mm/ universal

## + 12T HYDRAULIC CYLINDER 8 MM, STEEL



### Technical data

- Dimensions: Ø80x55 mm
- Pressure: max. 700 Bar
- Hole: Ø21.5 mm
- Connection: 3/8" -18 NPT

**GOLOCK** HYDRAULIC  
**GO** CODE **1012**  
with 1 pcs. 2 kg

**GOQUICK** HYDRAULIC  
**GO** CODE **1012Q**  
with 1 pcs. 2 kg

## + 12T HYDRAULIC CYLINDER 43 MM, ALUMINIUM



### Technical data

- Dimensions: Ø90x155 mm
- Pressure: max. 700 Bar
- Hole: Ø20 mm
- Connection: 3/8" -18 NPT
- Mounting thread: 2" 3/4-16 UN
- Adaptors: M10/M12/M14/M16/M18

**GOLOCK** HYDRAULIC  
**GO** CODE **1060**  
with 7 pcs. 2,4 kg  
§ **PATENTED**

**GOQUICK** HYDRAULIC  
**GO** CODE **1060Q**  
with 7 pcs. 2,4 kg  
§ **PATENTED**



## TOOL SET FOR REMOVING COMPACT WHEEL HUB/BEARING UNIT, MECHANICAL MAX 17 TON

**NEW**

Ø 62 Ø 66 Ø 68 Ø 72 Ø 78 Ø 82 Ø 85

### Application

Disassembly: it can work on bearings with an external from Ø62 mm up to Ø85 mm.

### Sizes and applications of the half shell set (HSS)

Half shell removal:  
1 x HSS for Ø 62, 66, 68, 72, 75, 78, 82, 85 mm/ universal



#### INCLUDED:

Lubricating grease to be used with threaded bars, nuts etc...

- The set contains tools for removing bearing units with diameters of 62-85 mm.
- This set can be expanded as required with the corresponding half shell sets for installation.
- The repair work can be performed directly on the vehicle.
- **Easy to use**
- **Significant time savings**
- **No damage to the bearing.**

<b>GO</b>	CODE	<b>055</b>
<b>T</b>	with 23 pcs.	<b>kg</b> 12,42 kg
<b>§</b>	<b>PATENTED</b>	



## TOOL SET FOR COMPACT WHEEL HUB/ BEARING UNIT, MECHANICAL **MAX 17 TON**

**NEW**

∅ 62 ∅ 66 ∅ 68 ∅ 72 ∅ 78 ∅ 82 ∅ 85



Slot for monitoring progress of operations

- Full assortment for correct removal and installation of compact bearing hub units on vehicles ranging from passenger cars to transporters.
- The perfect set for all current bearing units with diameters of 62 - 85 mm.
- Includes a threaded spindle M20 and nut, and a counter-pressure nut with pressure bearing for mechanical operation. For frequent use with large bearing units or badly corroded bearings, we recommend the optional 17-tonne hydraulics (optional).
- The special half shells grip behind the wheel hub during installation and press on the snap ring located directly on the bearing outer ring.
- **This prevents damage to the bearing and allows the snap ring to engage evenly.**
- **The repair work can be performed directly on the vehicle.**
- **Easy to use**
- **Significant time savings**
- **No damage to the bearing.**

**+** **INCLUDED:**  
 Lubricating grease to be used with threaded bars, nuts etc...

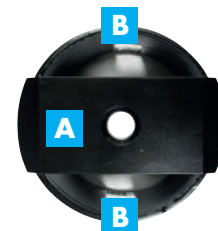

**A** Reinforced crossbar  
**B** Viewing windows 180° offset

**GO** CODE **054**  
 with 34 pcs. 24,52 kg  
**§ PATENTED**

### Application

- Ø62** Audi A2 - VW Lupo
- Ø66** Seat Cordoba 4 - Ibiza 3 (from 2005)  
Skoda Fabia (6Y) - VW Fox (ABS)/Polo 7, 8 (9N)
- Ø68** Citroën C3 -C4 (measure bearing diameter first) - Renault (Kadjar - Megane)

- Ø72** Audi A1/A2 (ABS) - Seat Cordoba 4/Ibiza 3, 4 (to 2005) - Skoda Fabia(6Y)/Fabia 2 (5J)/Roomster; VW Fox/Polo 7, 8 (9N)
- Ø78** Volvo C30/C70CC/S40 2/V50 - Ford C-Max/Focus 2 - Mazda 3 (BK)
- Ø82** VW Touareg/Porsche Cayenne
- Ø85** VW T5 (VA + HA)

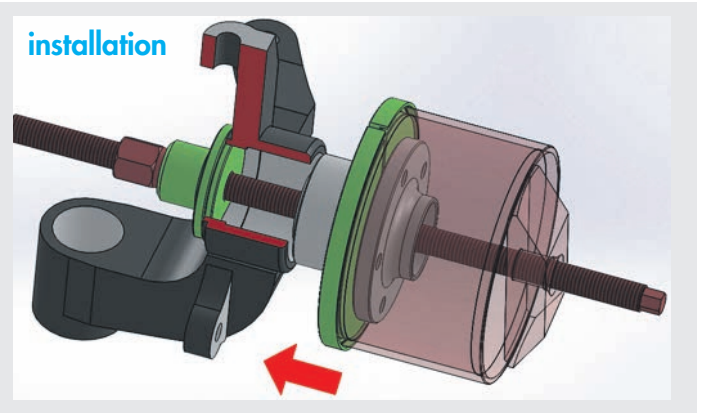
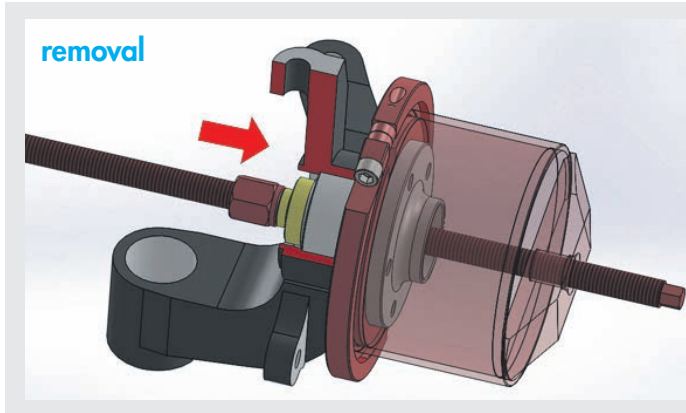

### Sizes and assignment of half shell sets (HSS)

#### INSTALLATION:

- 1 x HSS size 1 for Ø 62 mm
- 1 x HSS size 2 for Ø 66, 68 mm
- 1 x HSS size 3 for Ø 72, 75, 78 mm
- 1 x HSS size 4 for Ø 82, 85 mm

#### REMOVAL:

- 1 x HSS for Ø 62, 66, 68, 72, 75, 78, 82, 85 mm

## + 17T HYDRAULIC CYLINDER 43 MM, ALUMINIUM



### Technical data

- Dimensions: Ø90x155 mm
- Pressure: max. 700 Bar
- Connection: 3/8" -18 NPT
- Outside connection thread: 2" 3/4-16 UN
- Adaptors: M10/M12/M14/M16/M18

**GOLOCK**  
HYDRAULIC

**GO** CODE **1061**

T with 7 pcs. kg 2,2 kg

§ **PATENTED**

**GOQUICK**  
HYDRAULIC

**GO** CODE **1061Q**

T with 7 pcs. kg 2,2 kg

§ **PATENTED**

## + 17T HYDRAULIC CYLINDER 43 MM, STEEL



### Technical data

- Dimensions: Ø90x155 mm
- Pressure: max. 700 Bar
- Hole: Ø20 mm
- Connection: 3/8" -18 NPT
- Outside connection thread: 2" 3/4-16 UN

**GOLOCK**  
HYDRAULIC

**GO** CODE **1017**

T with 1 pcs. kg 4 kg

**GOQUICK**  
HYDRAULIC

**GO** CODE **1017Q**

T with 1 pcs. kg 4 kg



**+** HALF SHELL COUPLING

∅ 62



**Application**  
VW, Audi

**GO** CODE **032**  
with 3 pcs. **kg** 2,5 kg

**+** HALF SHELL COUPLING  
UNIVERSAL

∅ 72 ∅ 75 ∅ 78



**Application**  
∅ 72 Audi, Seat  
∅ 75 Mitsubishi, Smart  
∅ 78 Volvo

**GO** CODE **033**  
with 5 pcs. **kg** 4 kg

**+** HALF SHELL COUPLING  
UNIVERSAL

∅ 66 ∅ 68



**Application**  
∅ 66 Skoda  
∅ 68 Citroen, Renault

**GO** CODE **034**  
with 4 pcs. **kg** 3 kg

**+** HALF SHELL COUPLING  
UNIVERSAL

∅ 82 ∅ 85



**Application**  
∅ 82 Ford, Volvo  
∅ 85 4x4, SUV

**GO** CODE **035**  
with 4 pcs. **kg** 3,4 kg

**+** HALF SHELL COUPLING FOR  
BEARING FRONT AXLE

∅ 75

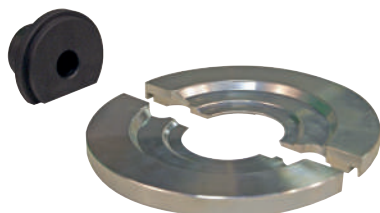

**Application**  
∅ 75 Mitsubishi Colt,  
Smart Forfour

**GO** CODE **036**  
with 3 pcs. **kg** 2,5 kg

**+** HALF SHELL COUPLING

∅ 92

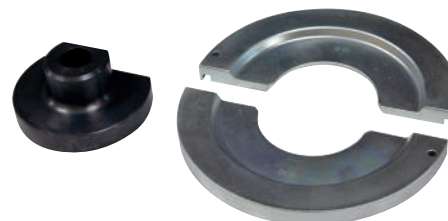

**Application**  
Citroen, Opel, Peugeot, Toyota:  
9819074780, SU001 A6528  
FAG: 713 6506 80  
SKF: VKBA 7120

**GO** CODE **039**  
with 3 pcs. **kg** 2,5 kg



**NEW**

**G SPECIAL XZN12 SOCKET SET VAG**

**L=72 MM**



**L=120 MM**



- For loosening the screw connection of the wheel bearing in the aluminium housing.

**Application**  
McPherson

**GO** CODE **369**  
with 1 pcs. **Kg** 0,32 Kg

**Application**  
four-link axle

**GO** CODE **368**  
with 1 pcs. **Kg** 0,25 Kg

**G SET OF XZN KEYS M6-8-10-12 x 150 mm**  
**VW GROUP**

**NEW**



- The 1/2" spherical head XZN socket set is ideal for working on hard-to-reach screw joints.
- It does not cause problems if the wrench and screw are not perfectly aligned.
- Ideal for VAG operations where many XZN screws are used in the chassis and engine sector.

**Application**

T10501 = XZN M10  
VW Golf 1.6L, 2.0L 4V A3 1.6L, 2.0L 4V TDI  
TDI (2013-2018), Audi (2013-2018)

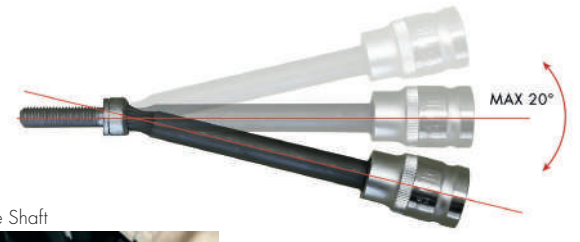

**GO** CODE **948**  
with 4 pcs. **Kg** 0,70 Kg

Rear axle stabiliser



Oil cooler



Cylinder head



Drive Shaft





## SET FOR DIS/MOUNTING BEARINGS

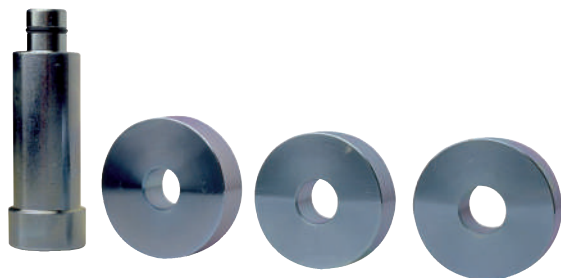

### Example of application



### Components

- 1 x pin Ø 20÷34 mm.
- 1 x washer Ø 63 mm.
- 1 x washer Ø 65 mm.
- 1 x washer Ø 71.5 mm.

- This tool is used to insert bearing race and seals without damage to race and axle housing.
- Set of three rounded plates and one hammer, to fit most standard wheel bearings.
- Use this tool in coupling with a press machine. Don't use hammers.

<b>GO</b>	CODE	<b>045</b>
1	with 4 pcs.	kg 2,4 kg



## WHEEL BEARING CIRCLIPS PLIERS SET



- Plier designed for introducing and removing cars and light commercial vehicles wheel bearing circlips.



### Components

- 1 x Ø tip 3.2 mm
- 1 x Ø tip 2.3 mm



<b>GO</b>	CODE	<b>801</b>
1	with 2 pcs.	kg 0,6 kg



## WHEEL BEARING CIRCLIPS PLIER



- Required for assembling and disassembling the wheel bearing elastic circlip without eyelet.

### Application

Citröen, Hyundai, Kia, Nissan, Peugeot, Renault, Toyota, Lexus

<b>GO</b>	CODE	<b>802</b>
1	with 1 pcs.	kg 0,2 kg

**G SLIDE HAMMER - 9 KG**



- For powerfully releasing components and for bodywork straightening jobs.
- Extremely effective loosening effect via impact with a maximum force of approx. 8 ton.
- It loosens even the most firmly seized or rusty components, or connected with a cone.
- With the relevant accessories, suitable for removing injectors, wheel hubs, supporting joints etc.



**GO** CODE **520**  
 T with 1 pcs. kg 11,6 kg

**Technical data**

- Slide hammer with weight: 9 kg
- Total length: 770 mm
- Connection thread: M18x1.5

**G SLIDING HAMMER 9KG, DEAD BLOW**

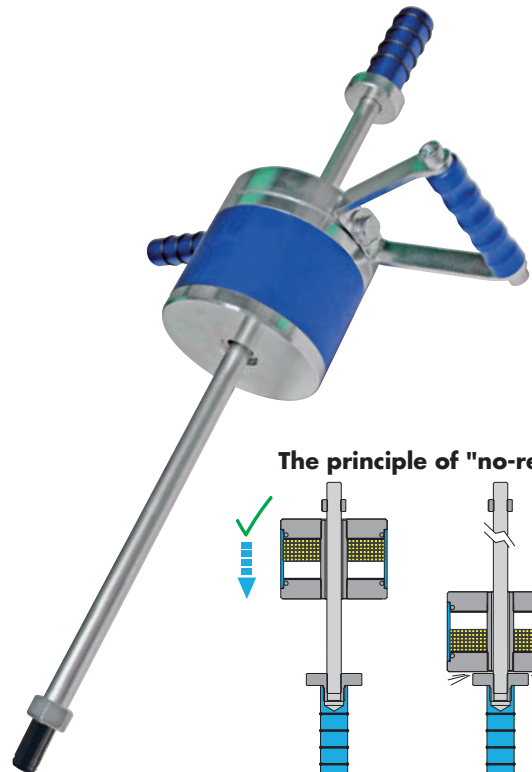

The principle of "no-rebound"

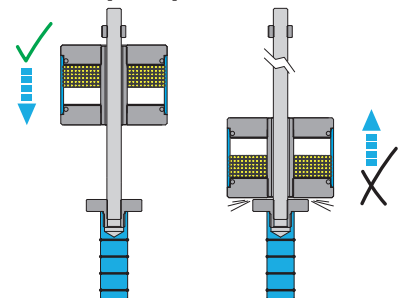

- For powerful expulsion of stuck components as well as for body straightening work.
- The new slide hammer version is filled with a steel shot. This prevents the weight from bouncing back against the abutment. The impact intensity is thus increased because the full impact force is transmitted to the component to be machined.
- This version is also very gentle on the joints and allows fatigue-free working.



**GO** CODE **530**  
 T with 2 pcs. kg 11 kg  
 § **PATENTED**



## + THREAD ADAPTERS SET



- Complementary assortment containing the four most commonly used adapters for slide hammers code **GO520** and **GO530**.

### Components and applications

1 x adapter, M18x1.5 for universal hooks/double extractor hooks/ bow hooks/bodywork pull clamps etc., suitable e.g. for the systems: Gmelin-Moll/Müller/Klann/KS/Kukko/ Pichler/Sauer/Sykes-Pickavant etc.

1 x adapter, M18x1.5/1-1/2 inch x 16 for wheel hub puller. Suitable e.g. for the systems: Würth Müller/KS/Sauer/Pichler/Kukko/BGS etc.

1 x adapter with ball joint, M18x1.5/ M18x1.5, for use between the slide hammer and the tool - enables work in hard-to-reach places - suitable for all systems

1 x adapter, M18x1.5/M22x2, for wheel hub puller, suitable e.g. for the following systems: Würth/Facom

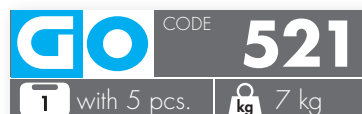

## + M18x1,5 ADAPTER

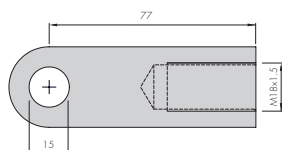

### Application

Suitable e.g. for the following systems: Müller, Klann, Ks, Kukko, Pichler, Sauer, etc.

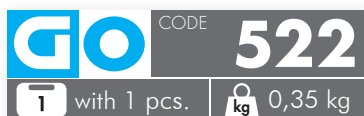

## + M18 - 1 1/2 UN16 ADAPTER

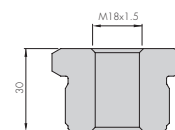

### Application

Suitable e.g. for the following systems: Müller, Ks, Kukko, Pichler, Sauer, BGS, etc.

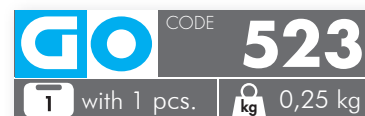

## + M22x2 - M18x1,5 ADAPTER

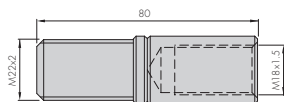

### Application

Suitable e.g. for the following systems: Würth, Facom.

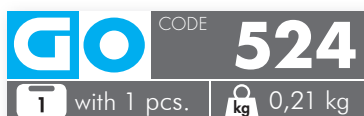

## + M18x1,5 - M18x1,5 ADAPTER

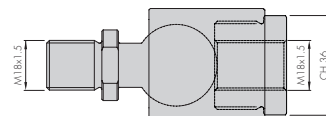

### Application

Suitable for all systems.

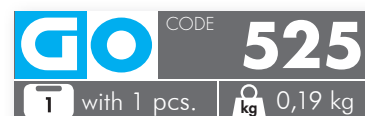



## 4-SIZE BALL JOINT SEPARATOR UNIVERSAL



- Universal application for thrust heads and transverse rods, as well as for support joints.
- Especially suitable for new car models with multi-link aluminium suspensions where ball joints are often very big and very close together.
- It includes a pushing spindle with trapezoidal thread for impact wrench.
- The functioning system, on parallel plans, prevents damages to the components and reduces the execution time.



Fork opening (A)	Working range (B)
24 mm	25 - 90 mm
27 mm	
31 mm	
36 mm	

### Application

For cars, vans and small-sized commercial vehicles. Examples: VW/Audi, BMW, Mercedes Benz and Porsche.

**GO** CODE **380**  
 1 with 6 pcs. **kg 6 kg**

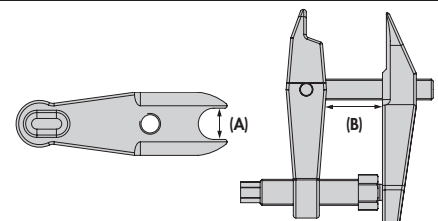

**G** BALL JOINT BI-HEX SOCKET  
 FOR MB MERCEDES



**G** BALL JOINT BI-HEX  
 SOCKET 32 MM FORD



**Technical data**

- Drive 1: size 30
- Drive 1: 1/2"
- Size: 43 mm (tip to tip)
- Height: 40 mm

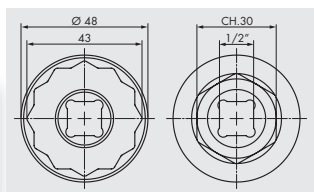

**GO** CODE **351**

1 with 1 pcs. **kg** 0,2 kg

**Technical data**

- Size: Ø48 mm
- Height: 50 mm
- Drive 1: CH31,5
- Drive 2: 1/2"
- Drive 3: CH30

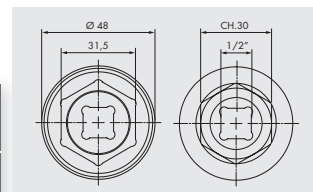

**GO** CODE **354**

1 with 1 pcs. **kg** 0,2 kg

**G** BALL JOINT BI-HEX SOCKET  
 32 MM FOR MERCEDES BENZ



**G** BALL JOINT BI-HEX SOCKET  
 24 MM FOR MERCEDES BENZ



**Technical data**

- Size: Ø42 mm
- Drive 1: size 32
- Drive 1: 1/2"
- Height: 40 mm

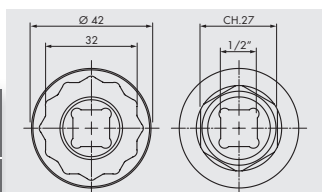

**GO** CODE **352**

1 with 1 pcs. **kg** 0,2 kg

**Technical data**

- Size: Ø42 mm
- Drive 1: size 24
- Drive 1: 1/2"
- Height: 40 mm

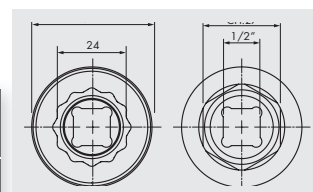

**GO** CODE **353**

1 with 1 pcs. **kg** 0,2 kg





## SOCKET WRENCH FOR REMOVAL AND ASSEMBLY OF THE STEERING HEAD

**NEW**

- This special socket wrench allows for the disassembly and reassembly of ball joints screwed onto the car's front axle. There can be different sizes depending on the original head present on the cars.
- Due to its special conical structure feature, it fits perfectly onto the conical walls of the ball joint head and couples perfectly with the hexagon for moving it, solidly locking by screwing the nut on the upper part, on the thread that protrudes from the mounting and disassembly socket once coupled.

**SW.46 MM**



**Technical data**

- External drive SW.36

<b>GO</b>	CODE	<b>363</b>
<b>T</b>	with 3 pcs.	<b>Kg</b> 0,54 Kg
<b>§</b>	<b>PATENTED</b>	

**SW.44 MM**



**Technical data**

- External drive SW.32

<b>GO</b>	CODE	<b>364</b>
<b>T</b>	with 3 pcs.	<b>Kg</b> 0,35 Kg
<b>§</b>	<b>PATENTED</b>	

**SW.50 MM**



**Technical data**

- External drive SW.32

**Application**

Hyundai I30, Elantra  
Kia Ceed, Proceed,  
Carens

<b>GO</b>	CODE	<b>372</b>
<b>T</b>	with 3 pcs.	<b>Kg</b> 0,30 Kg
<b>§</b>	<b>PATENTED</b>	



# G PRESS FRAME SET - 12 TON STEEL



- The compression frame is used to disassemble and assemble silent bearings, sockets and bushings in passenger cars, SUVs and vans.
- The range of tools specially designed for this use provides the user with a very high level of flexibility in machining the most varied types of bushings, installation positions and sizes. Consequently, tight bushings (adherent), open and closed bushings or even particularly long bushings can be handled without any problems.
- Thanks to this frame's slender but also especially solid shape, the job can be done, depending on where access is, directly on the car or before assembly.
- Even with regard to the drive, the user has several options: he/she either uses the mechanical spindle provided in the supply or adapts the equipment to the hydraulic variant.
- With the help of the available supports, the kit adapts very well when used in conjunction with our universal **GO140** traction and compression system.

### Frame technical data

- Total height: 290/415 mm
- Total width: 170 mm
- Internal width: 113 mm
- Internal height: 210/335 mm
- Spindle screw: TR27 / 1-1/2"x16G / 2-3/4"x16G (upper crosshead) TR20 (lower crosshead)

### Components

- 1 x upper crosshead with 2 x thread reducer ring
- 1 x drive spindle TR27
- 1 x plug-in adaptor for spindle TR27 with cylinder mount
- 2 x enlargement for plug-on and plug-in adaptor with cylinder mount
- 1 x lower crosshead with thread TR20

- 1 x spindle TR20, short with plug-in holder for system adaptor
- 1 x spacing and working spindle TR20 with plug-in holder for system adaptor
- 1 x plug-on adaptor for spindle TR20 with plug-in holder
- 2 x tension struts 270 mm
- 2 x tension struts extension 100 mm

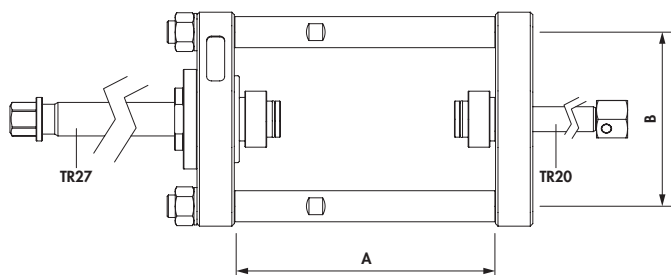

	MIN (mm)	MAX (mm)
A	210	335
B	115	

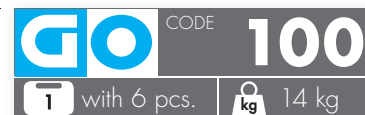

**+ HYDRAULIC ALUMINIUM PUMP - HAND OPERATED 700 BAR**

**Technical data**

- Maximum working pressure: 700 bar
- Speed/stroke: single
- Oil tank volume: 700 cm<sup>3</sup>
- Oil volume per stroke: 500 cm<sup>3</sup>
- Oil displacement per stroke: 1.8 cm<sup>3</sup>
- Max effort on the handle to 700 bar: 46 kg
- Piston stroke: 24 mm
- Ø piston: 10 mm
- Connection: 3/8" NPT
- Hose length: 1.8 mt



**GOLOCK**  
HYDRAULIC  
**GO** CODE **1030**  
with 1 pcs. 4,7 kg

**GOQUICK**  
HYDRAULIC  
**GO** CODE **1030Q**  
with 1 pcs. 4,7 kg

**+ 12T HYDRAULIC CYLINDER ALUMINIUM, 43 MM**



**Technical data**

- Dimensions: Ø90x155 mm
- Pressure: max. 700 Bar
- Hole: Ø20 mm
- Connection: 3/8" -18 NPT
- Mounting thread: 2" 3/4-16 UN
- Adaptors: M10/M12/M14/M16/M18

**GOLOCK**  
HYDRAULIC  
**GO** CODE **1060**  
with 7 pcs. 2,4 kg  
§ **PATENTED**

**GOQUICK**  
HYDRAULIC  
**GO** CODE **1060Q**  
with 7 pcs. 2,4 kg  
§ **PATENTED**

**+ M18 SCREW INTEGRATIVE SET**



- To be use with the hydraulic cylinders.



**Components**

- 1 x adapter
- 1 x screw M18x1.5 - L=110 mm

**Application**

To be used with GO100, GO110

**GO** CODE **115**  
with 2 pcs. 0,2 kg





## PRESS FRAME SET FOR SILENT BLOCK - 12 TON ALUMINIUM, LIGHTWEIGHT

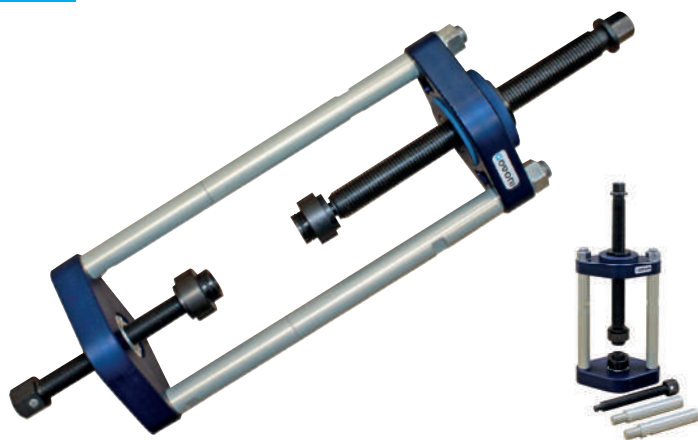

	MIN (mm)	MAX (mm)
A	210	335
B	115	

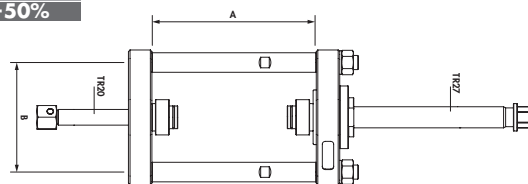

- The compression frame is used to disassemble and assemble silent bearings, sockets and sleeves in passenger cars, SUVs and vans. The range of tools specially designed for this use provides the user with a very high level of flexibility in machining the most varied types of bushings, installation positions and sizes.
- Consequently, tight bushings (adherent), open and closed bushings or even particularly long bushings can be handled without any problems. The job can be done directly on the car or before assembly.

**GO** CODE **105**  
with 6 pcs. 10 kg

## + 12T HYDRAULIC CYLINDER ALUMINIUM



### Technical data

- Dimensions: Ø90x155 mm
- Pressure: max. 700 Bar
- Hole: Ø20 mm
- Connection: 3/8" -18 NPT
- Mounting thread: 2" 3/4-16 UN
- Adaptors: M10/M12/M14/M16/M18

## + BUSH & BEARING REMOVAL PRESS AND PULL SLEEVE KIT UNIVERSAL, CAR



- Handy assortment of sleeves and spindles for pressing out and inserting round bearings.
- Cost-effective alternative to vehicle-specific tool sets.

**LOCK** HYDRAULIC  
**GO** CODE **1060**  
with 7 pcs. 2,4 kg  
§ PATENTED

**QUICK** HYDRAULIC  
**GO** CODE **1060Q**  
with 7 pcs. 2,4 kg  
§ PATENTED

**GO** CODE **140**  
with 41 pcs. 9 kg  
§ PATENTED





## PRESS FRAME SET - 17 TON - STEEL



- The compression frame is used to disassemble and assemble silent bearings, sockets and bushings.
- Due to this frame's sizeable opening range of 135 mm, it is also suitable for OffRoaders, vans and lightweight commercial vehicles.
- The range of tools specially designed for this use provides the user with a very high level of flexibility in machining the most varied types of bushings, installation positions and sizes. Consequently, open and closed bushings or even particularly long bushings can be handled without any problems.
- Thanks to this frame's slender but also especially solid shape, the job can be done, depending on where access is, directly on the car or before assembly.
- Even with regard to the drive, the user has several options: he/she either uses the mechanical spindle provided in the supply or adapts the equipment to one of the 3 hydraulic variants available. (16-ton Mechadraulic-Spindle, 12- or 17-ton Hydraulic cylinder).
- With the help of the available supports, the kit adapts very well when used in conjunction with our universal **GO140** traction and compression system.

### Components

- 1 x upper crosshead with 2 x thread reducer ring
- 1 x lower open crosshead to be used with commercially available pressure kits
- 1 x insert ring for lower, open crosshead for mounting commercial, vehiclespecific pressure kits/e.g. Müller/Sauer/SW-Stahl/KS Tools/Walmek/Paschke etc.
- 1 x lower traverse, closed with thread TR20
- 1 x short screw TR20 with inner thread for mounting and fixing pull and pressure system adaptors
- 1 x drive spindle TR27
- 1 x spacing and work spindle TR20 for distance adjustment from below
- 2 x holder adaptor for Govoni pull pressure system
- 2 x tension struts 210 mm
- 2 x tension struts extension 125 mm

### Frame Technical data

- Total height: 330/430 mm
- Total width: 197 mm
- Internal width: 135 mm
- Internal height: 270/370 mm
- Spindle screw: TR27 / 1-1/2"x16G / 2-3/4"x16G (upper crosshead) TR20 (lower crosshead)

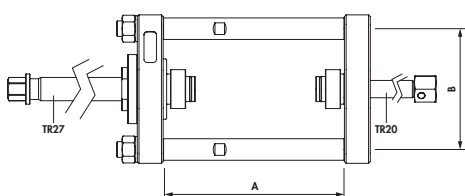

	MIN (mm)	MAX (mm)
A	270	370
B	135	

**GO** CODE **110**  
1 with 5 pcs. **kg** 12,2 kg

## + 12T HYDRAULIC CYLINDER 120N, 43 MM, ALUMINIUM



### Technical data

- Dimensions: Ø90x155 mm
- Pressure: max. 700 Bar
- Hole: Ø20 mm
- Connection: 3/8" -18 NPT
- Mounting thread: 2" 3/4-16 UN
- Adaptors: M10/M12/M14/  
M16/M18

**GOLOCK**  
HYDRAULIC

**GO** CODE **1060**

**T** with 7 pcs. **kg** 2,4 kg

**§** **PATENTED**

**GOQUICK**  
HYDRAULIC

**GO** CODE **1060Q**

**T** with 7 pcs. **kg** 2,4 kg

**§** **PATENTED**

## + 16TON MECHADRAULIC- SPINDLE ADAPTOR KIT



### Technical data

- Force: 16 ton
- Dimensions: Ø38x225x345 mm
- Driving torque: 38 Nm
- Receiving thread: 1-1/2 inch x  
16 tpi
- Stroke: 20 mm
- Weight: 1,7 kg

**GO** CODE **1016**

**T** with 7 pcs. **kg** 2,2 kg

## + M18 SCREW INTEGRATIVE SET



- To be use with the hydraulic cylinders.



### Components

- 1 x adapter
- 1 x screw M18x1.5 - L=110 mm

### Application

To be used with GO100, GO110

**GO** CODE **115**

**T** with 2 pcs. **kg** 0,2 kg





## UNIVERSAL C-BRACKET UNIVERSAL

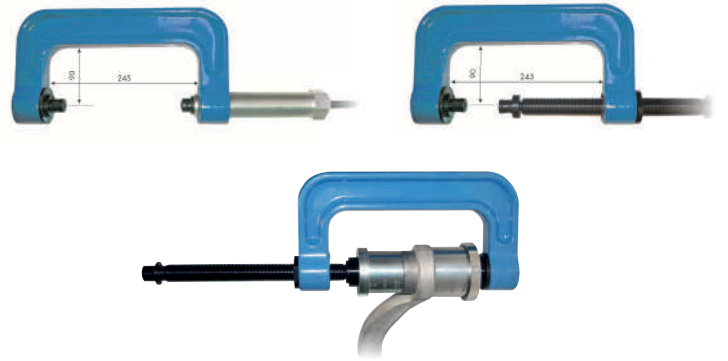

- With the aid of the C-bracket and the optional matching pressure pieces carrying joints, silent bearings, bushings and sleeves are directly pressed on and out of the vehicle. The tool is supplied with a trapezoidal thread spindle Tr27 and the removal of the threaded adapter enables the retrofitting of the 16to Mechadraulic spindle.
- Both retainer adapters allow the direct removal from the pressure plates from the Govoni **GO140** Universal tool set for the dismounting and mounting of bushes, bearings and sleeves.

**GO** CODE **120**  
 with 1 pcs. **kg** 8 kg

### Components

- 1 x C-bracket with threaded adapter AG 1-1/2"-16to x IG Tr27
- 1 x trapezoid thread spindle Tr.27x250 mm

- 2 x retainer adapters for sleeve mounting plates.
- 2 x retainer adapters for sleeve mounting plates GOVONI.



## SILENTBLOCK TOOL SET FOR FCA, FIAT, FORD AND OPEL

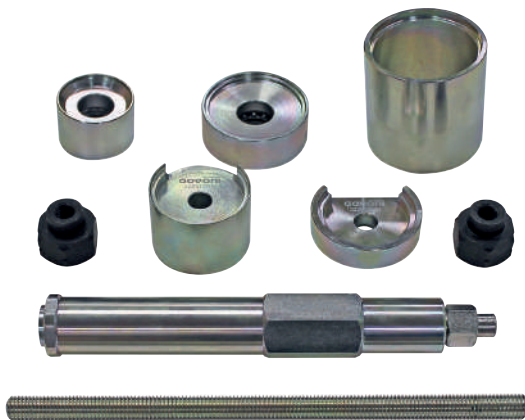

- Kit suitable for Silentblock rear axle.
- Tool for correct Silentblock mounting and dismounting.
- Safety use, without damaging arms.

### Application

Silentblock	Brand	Model
Ø 45 mm	Fiat	Panda (4x4 - Cross - Metano)
Ø 45 mm	Fiat	500
Ø 45 mm	Ford	Ka
Ø 54 mm	Ford	Ka
Ø 54 mm	Opel	Adam

**GO** CODE **130**  
 with 10 pcs. **kg** 9 kg

# G BUSH & BEARING REMOVAL PRESS AND PULL SLEEVE KIT Ø 74/84 - 100/110 mm **NEW**

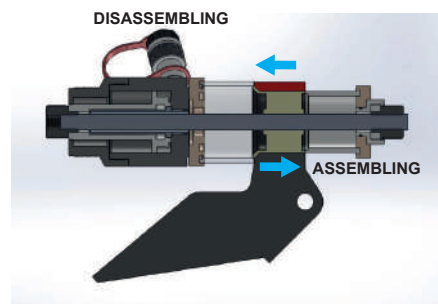

- Kit used for dis/assembling bearings, bushings, sleeves, sealing rings, etc.
- It is an economical alternative to hub/bearing press set specific per each automotive brand.
- It can be used mechanically or hydraulically (optional components)
- It can be used on vehicle, workshop press, C-frame, vise, etc.
- All pieces can also be purchased individually.
- Also ideal as an upgrade of the GOVONI set, art. **GO140**

### ADVANTAGES

- The sleeves can be machined mechanically.
- Optimal adapting to the work to be done!
- Ø of the sleeves increasing by 2 mm (high dimensional coverage)
- Stackable sleeves for long and short components
- The extra-long spindles (450 mm) can withstand high tensile loads
- Minimal resistance thanks to the integrated thrust bearing.

  **GO** CODE **142**  
 with 34 pcs.  13,6 Kg  
 § **PATENTED**

# G UNIVERSAL BUSH AND BEARING REMOVAL PRESS AND PULL SLEEVE KIT Ø 34/44 - 82/92 mm



- Handy assortment of sleeves and spindles for pressing out and inserting round bearings.
- All sleeves can be machined and adapted according to the application.

### Application

Silent bearings  
Wheel bearings

Sleeves  
Bushings made from metal/  
plastic/brass etc.

**GO** CODE **140**  
 with 41 pcs.  9 kg  
 § **PATENTED**



**Modulate mounting bushing**

to remove silentblock up to L=100 mm

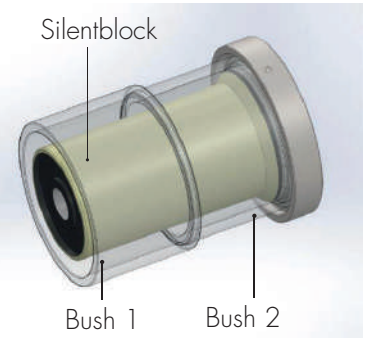

**+ 12T MECHADRAULIC CYLINDER-SET ALUMINIUM**



**Technical data**

- Force: 12 ton
- Stroke: 8 mm
- Dimensions: Ø80x260x45 mm
- Pressure: max. 700 Bar
- Hole: Ø21,5 mm
- Driving torque: 56 Nm
- Weight: 1,65 kg
- Grease temperature range of

use: from -25°C to 80°C

- Material: aluminium
- Adaptors: M10/M12/M14/M16/M18

**GO** CODE **1015**  
 with 7 pcs. 1,8 kg  
**§ PATENTED**

**+ 17T HYDRAULIC CYLINDER, 43 MM, ALUMINIUM**



**Technical data**

- Dimensions: Ø90x155 mm
- Pressure: max. 700 Bar
- Connection: 3/8" -18 NPT
- Outside connection thread: 2" 3/4-16 UN

- Adaptors: M10/M12/M14/M16/M18

**GOLOCK** HYDRAULIC  
**GO** CODE **1061**  
 with 7 pcs. 2,2 kg  
**§ PATENTED**

**GOQUICK** HYDRAULIC  
**GO** CODE **1061Q**  
 with 7 pcs. 2,2 kg  
**§ PATENTED**





## DEVICE FOR SWINGING ARMS AND SHOCK ABSORBERS REMOVAL - SINGLE ARM SYS. MAX TORQUE 50 Nm



### Case 1

Removal of both oscillating arms

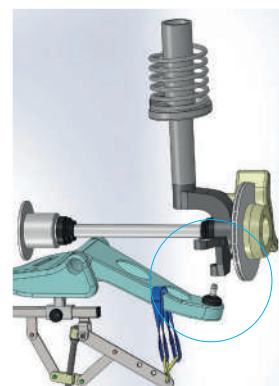

### Case 2

Removal of shock absorber

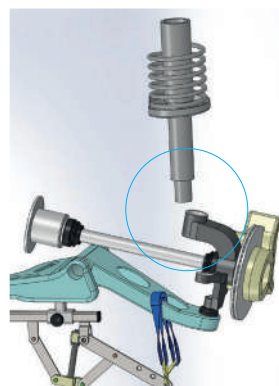

- Only one operator required to carry out the entire assembly.
- Case **1**: Removal of both oscillating arms. Case **2**: Removal of shock absorber.
- Ultra-fast operation: use of impact gun.
- Sliding support foot to fit any underbody.
- Suitable for all cars and commercial vehicles.



**GO** CODE **371**  
 with 1 pcs. 8,7 kg  
**§ PATENTED**



### Advantages

- 75% Time Saving compared to traditional mounting systems
- 50% Time Saving compared to traditional lever arm detaching tools on the market

### Technical data

- Length: 1.233 mm
- Height: 526 mm
- Width: 122 mm



**DEVICE FOR SWINGING ARMS AND SHOCK  
ABSORBERS REMOVAL - DOUBLE ARM SYS.  
MAX TORQUE 50 Nm**



**Case 1**

Removal of both oscillating arms

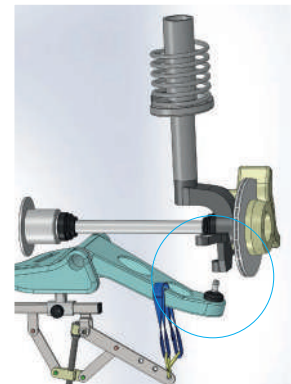

**Case 2**

Removal of shock absorber

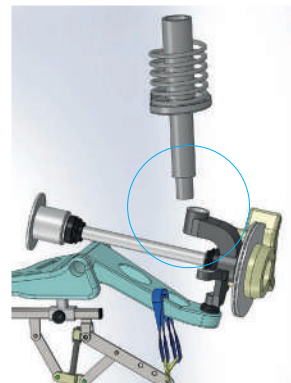

- Creates maximum clearance for repair work without the need for additional loosening or removal of various axle components.
- Overcomes even high levels of counter tension on the steering arm with minimal force and prevents damage to the dust boot on the supporting joint.
- Detachment through belt which guarantees utmost safety and keeps arms intact.
- Sliding support feet to fit any underbody.



**Technical data**

- Length: 1000 mm
- Height: 120 mm
- Width: 450 mm
- Ultra-fast operation: use of impact gun

**GO** CODE **370**  
 1 with 1 pcs. 13,2 kg  
 § **PATENTED**



**Application**

- Universal, for removing and installing axle components on anything from a passenger vehicle to a transporter; current example is Nissan Qashqai J11 - servicing operation on front axle.
- Enables easier removal of the damper unit from the clamping bore.
- No tilting when positioning the supporting joint pin on the axle.
- Maximum clearance for work on the drive shaft etc.



## SHOCK ABSORBERS, SWIVELLING ARMS, STEERING BOX CLAMP SPREADER TOOL KIT **UNIVERSALE**



- Tool kit allowing the enlargement of shock absorbers clamping bores, balljoints, steering box etc.
- Adjustable and adaptable to both single and double clamping bore, especially for VW-Group.
- Suitable for aluminium and cast-iron clamping bores (no damage risk).

### Case 1 Single clamping Bore

#### Technical data

A: 74,8 mm  
 B: 22 mm  
 C: min. 11.5 mm - max 24.5 mm

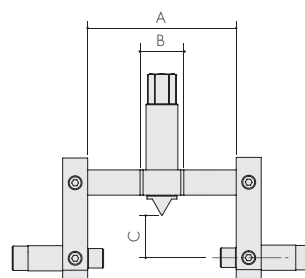

### Case 2 Two clamping bores

#### Technical data

A: 94,8 mm  
 B: 70 mm

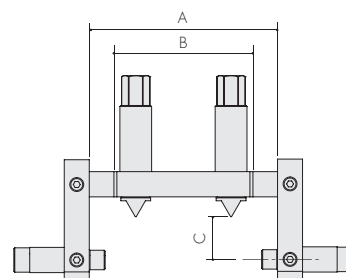

Application on swivelling arms.



Application on VW double joint.



Application on steering box.



Application on shock absorber.



#### Application

Wide range of application: VW Group, BMW, Ford, PSA, Renault, Nissan etc



<b>GO</b>	CODE	<b>361</b>
<b>T</b>	with 20 pcs.	<b>kg</b> 2,4 kg





## SINGLE LOCKING JOINT SPREADER

**NEW**



### Application

Universal use BMW, Citroen, Peugeot, VAG, Ford.

serviceable from both sides



makes the assembly and disassembly easier damage to the axle joint housing (cast or aluminium) is avoided optimal adjustment, therefore slips are almost impossible.



- Ideal for splaying the axle joint clamp boreholes, or ball joint attachments.
- It is necessary to remove the secured spring absorber unit from the axle joint clamp boreholes.



CODE **314**

### Technical data

- Jaw width: 38mm
- Closed height: 33mm
- Working range: 3.9-15mm

**T** with 1 pcs.

**kg** 0,21 Kg



## EXTRACTOR FOR STEERING SYSTEM UNIVERSAL



CODE **356**

### Technical data

- Passengers cars and trucks:  
Ø 43.2 mm - 20,25 mm

**T** with 1 pcs.

**kg** 1 kg



## CLAMP SPREADER SUPPLEMENTARY KIT



- Additional set for **GO360**: 3 new wedge shapes and a new couple of locking bolt, allowing the operator to work on bigger and deeper joints (e.g. Peugeot, VW etc.).
- The new dimension of the locking bolt covers the previously lacking one and grants a secure hold.

### Components

2 x fixing nuts Ø9/Ø11

3 x spreader clamps  
(11 mm/13 mm/18 mm)



CODE **362**

**T** with 5 pcs.

**kg** 0,2 kg



## EXTRACTOR FOR STEERING SYSTEM UNIVERSAL



CODE **357**

### Technical data

- Passengers cars and trucks:  
Ø 45.2 mm - 32,25 mm

**T** with 1 pcs.

**kg** 1,2 kg



## WISHBONE AND MULTILINK SYSTEM COIL SPRING COMPRESSOR UNIVERSAL



- Designed for professional and safe compression of coil springs for wishbone (wishbone) and multi-link (multi-link) suspension. Not suitable for conical and cylindrical helical springs.
- The extremely compact design allows the tool being used on vehicles with a very small through hole on the rear spring holder, up to Ø30 mm. This makes it one of the few tools on the market for internal spring compression.
- The inclination of the jaws adapts perfectly to the compression of the spring and guarantees a secure grip.
- The safety dynamometric extension simplifies the positioning of the tool on the spring and prevents its overload (Max torque 40 Nm).

The only set on the market capable of handling among others the following coil spring:

BRAND / MODEL	YEAR	FRONT / REAR
Citroen C1	2006-	Rear
Citroen C3	2003-	Rear
Kia picanto	2007-	Rear
Mitsubishi Colt	2007-	Rear
Peugeot 107, 207, 1007	2007-	Rear
Skoda Octavia	2001-	Rear
Skosa Roomster Scout	2008-	Rear
Suzuki Swift, SX4	2007-	Rear
Toyota Aygo	2007-	Rear
VW Touran	2003-	Rear
BMW Serie 3 (E91)	2007-	Rear
Citroen C4	2006-	Rear
Mercedes Benz Classe C (W202)	1993-2000	Front
Honda Civic, Stream	2007-	Rear
Kia Ceed	2007-	Rear
Mazda 3	2003-	Rear
Mitsubishi Shogun, Pajero	2007-	Rear
Renault Traffic	2007-	Rear
Skoda Fabia	2007-	Rear
Toyota Yaris	2007-	Rear
Volvo V70	2007-	Rear
VW Polo	2007-	Rear

### Components

- 1 x torque stick (safety key), 40 Nm
- 2 x jaws type 1, for spring coil spring Ø90-120 mm
- 2 x jaws type 2, for spring coil spring Ø120-140 mm
- 1 x compressor

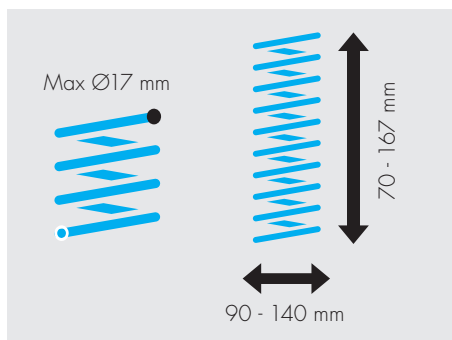

### Technical data

- Maximum load: 1.500 kg (15000 N)
- Minimum distance between jaws: min. 96 mm - max 220 mm
- Maximum stroke: 124 mm
- Dim. body (D x L): Ø 29x225-280 mm
- Max torque: 40 Nm

**GO** CODE **359**  
1 with 6 pcs. **6,7 kg**



## MECHANICAL COIL SPRING COMPRESSOR



For compressing installed coil springs directly on the vehicle.



- Suitable as a removal aid for MacPherson spring struts, for rear axle springs and for broken springs.
- Enables the removal of the spring strut from the clamping bore in the axle casing without additional removal of various axle components or without lowering the sub-frame (support frame).
- Non-slip as each spindle has a right- and left-hand thread.
- Saves considerable time and money, as there is no need for a complicated wheel alignment.
- The short spindles allow particularly long rear axle springs to be pre-tensioned so that they can be removed safely and without residual tension.
- Don't use the tool on the bench. Use the tool directly on the auto vehicle.



### INCLUDED:

Lubricating grease to be used with threaded bars, nuts etc...

### Technical data

- Max. load: 800 kg/8.000 N
- Clamping width: Ø100 - 300 mm
- Clamping range: short spindle 90 - 180 mm, long spindle 110 - 315 mm

### Components

- 4 x spring mounts, plastic-coated
- 2 x spindles M18, L=340 mm
- 2 x spindles M18, L=185 mm
- 1 x spring coil fixing tools

### Application

E.g.: VW Group Golf IV, V, VI, Touran, Passat, Audi A3, TT, Skoda Octavia, Seat Leon etc.

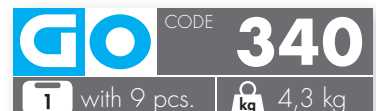





## SHOCK ABSORBER TOOLS SET FOR PISTON ROD



### Components

- 3 x ratchet wrenches with through hex to actuate the special sockets
- 7 x special sockets, 83 mm long, open. For automatic-fixing fastening nuts on the piston rod
- 10 x bit sockets, 100 mm long, to counteract the piston rod
- 2 x teeth wrenches for toothed nut on the piston rod VW Group/MB

- Tool set to counteract the shock absorber's piston rod and, at the same time, to loosen and tighten the retaining nuts on the rod.
- Suitable for many MAC-Pherson suspensions.
- For removing suspensions after clamping the spring.
- Using a coupling torque wrench and its set of keys (ring or combination), the nut can be tightened all the way, during assembly, through the default torque.



**GO** CODE **345**  
with 22 pcs. 4,2 kg



## TOOL FOR SHOCK ABSORBER STRUT WITH OVAL PIN UNIVERSAL



- Ideal for retaining the shock absorber strut during the assembly and disassembly phase of the rear shock absorber upper support. It lets you hold the piston strut up when loosening the fixing nut on the bearing of the support.
- Suitable for all shock absorbers with oval pin
- With 2 different sizes per tool: 5x8mm and 6x9mm
- Safer and easier to handle than locking pliers.



The ends of the tools are slightly elbow-shape bent, thus leaving more room for unscrewing operations

**Application**  
VW, Audi, Ford, Opel

**GO** CODE **384**  
with 1 pcs. 0,2 kg

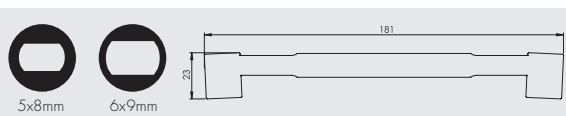



## MACPHERSON STRUT SUPPORT FOR JACK CAPACITY 120 KG



- Can be used to support the shock absorber when the suspension arm is removed. The shock absorber support is used together with a standard transmission jack. Used to prevent the shock absorber from sinking when removed from the handlebar arm.
- What is new is the adapter plate for the fork attachment Ø60mm, which extends the field of application.
- The supply includes two mounting sleeves for Ø25 and 30 mm piston rods.



### Components

1 x Macpherson strut support
1 x safety bracket 80 mm
1 x reduction for strut support to 60 mm
1 x Ø 25 mm adapter
1 x Ø 30 mm adapter

**GO** CODE **316**  
 with 3 pcs. **3 Kg**

**+** **PLUS:**  
 the new adapter plate extends the field of application!



## STUB AXLE PROP UNIVERSAL



- The universal wheel hub holder is V-shaped and therefore can be fixed on the bolts of all hubs, designed to be coupled with the bolts that secure the wheels.
- The kit include the adapters for hydraulic pit jacks piston rod Ø 25 and 30mm.
- Compatible with approximately 95% of hydraulic pit jacks, thanks to the adapters for various piston rod diameters supplied with the kit.

### Application

1. Disassembly and assembly of the upright and the support joint or trapezoid of the suspension cross arm.
2. Load bearing test according to manufacturer specifications to highlight noise.

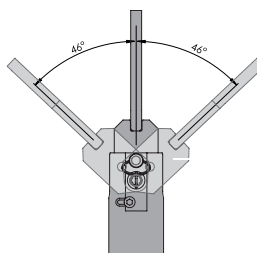

**MAX LOAD 330 Kg**  
**FOR WHEEL BOLTS MAX: M16**

**Application**

- With cone or spherical collar attachment
- The V-shaped prop rotates by 46° and can be locked in a central position

On request:  
**GO1450, GO1451, GO1452, GO1453**

### Technical data

- Max. load: 330 kg
- Total length: 225 mm
- Assembly: Ø40mm
- Tilt angle: ± 46 ° (forwards + backwards)
- For wheel bolts: max. M16

**GO** CODE **366**  
 with 3 pcs. **1,5 Kg**



## WHEEL ALIGNMENT CAMBER DEVICE UNIVERSAL



Use directly on the hub wheel

- Special diagnostic tool set, necessary for strain detection on hubs, shock absorbers and rear axle; with this tool the operator is able to find the non-conforming parts that have to be replaced because of collisions or potholes on the road.
- Collisions or potholes on the road, pavement and crashes in general, cause damage to the suspension system and corrupts the camber measure. This results in unroadworthy vehicles and unusual tyre usage.
- Allows the user to identify what is compromising the camber measure between the hub and shock absorber.

### Example of application

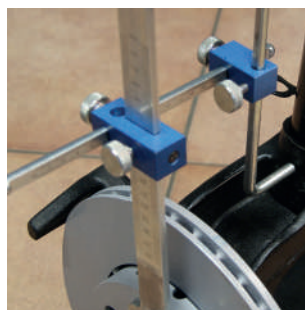

Adjust the pointing measuring tool against the fixing shock-absorber seat.

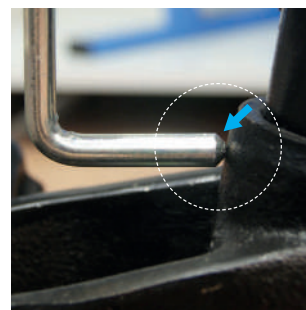

Refine measurement using the pointer stick.

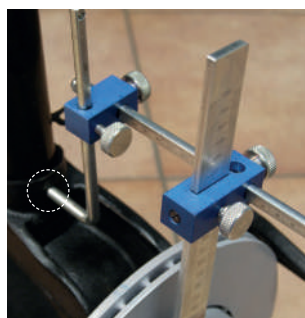

Unscrew the fixing bolt from the disc and mount the wheel alignment tool on the opposite hub wheel.

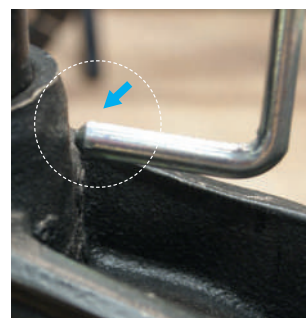

If the pointer stick is in a different position, the result is the hub needing to be replaced. If the pointer stick fails to reach the suspension, the problem is with the shock absorber.

**GO** CODE **350**  
 with 18 pcs. 1,3 kg  
 § **PATENTED**







# STRUT CONTROLLER UNIVERSAL



- Shock absorber installation kit, for assembly/disassembly of shock absorbers with tension stop springs (BILSTEIN). The ideal solution for new generation shock absorbers equipped with gas hydraulic piston, with automatic retraction.
- Enables piston rods to be removed and secured without damage and prevents the piston rod retracting when only the spring is being replaced.
- Integrated and upgraded with two spacers, to be used when working on shock absorbers with very long rods.
- Springs no longer need to be compressed to the maximum level, resulting in a safer clamping process.
- Fixing nut is easy to screw on to the piston rod during installation.
- Universal Delrin® clamp to lock the shock absorber rod and refit the spring.

### Example of application



Position the clamp with the fixing screws. Do not tighten.



Screw the rod-puller into the support and place the shock absorber rod to the rod-puller, using the locking nut.



Remove the stem puller and lock it with a slight rotation to the right or left. NB: it is possible to extract the stem by another 20 mm keeping the support still and turning the stem puller.



When the removal is completed, lock the clamp with the screws.



If rod-puller stroke is insufficient: insert one or both spacers (provided) between the support and the clamp in order to further extract the shock absorber rod.



Remove the rod-puller after locking the clamp in its final configuration. Mount the spring and remove the clamp.

### Minimum stroke in resting position

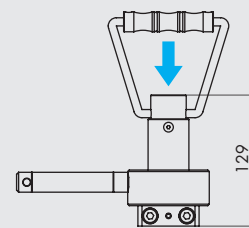

### Maximum stroke condition including spacers

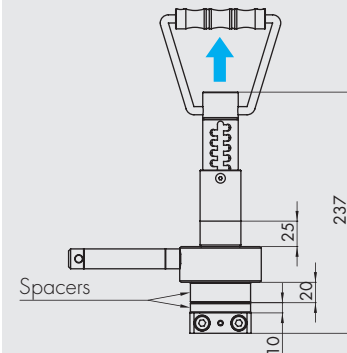

### Components

- 1 x telescopic pulling attachment, 2 pieces
- 1 x mounting cylinder for pulling attachment
- 1 x clamping jaw with screws
- 1 x clamping jaw screws for piston rod, diameter up to 28 mm
- 2 x spacers, H = 10 mm/H = 20 mm
- 1 x spanner

### Technical data

- Clamping range, Ø 12-28 mm (piston rod)
- Clamping jaw material: aluminium with plastic insert
- Height, min./max.: 129/237 mm

**GO** CODE **355**  
 1 with 8 pcs. **3,2 kg**  
**§ PATENTED**

### Application

Audi, Bmw, Citroën, Fiat, Ford, Mercedes, Nissan, Opel, Peugeot, Toyota, VW, on models that are equipped with Bilstein shock absorbers



## BRAKE SPRING INSERTION TOOL

**+** **PLUS:**  
 It has a hole for hanging it



- Used for Mercedes-Benz parking brakes
- To mount and dismount the clamping springs of the handbrake jaws (rear disc brakes).
- Guide slot in the functional area
- Reaches the support spring sideways behind the hub, it can be used in tight spaces!

### Application

Parking brake support springs (rear disc brake) for Mercedes class V Vito and Viano (type 638) 1996 - 2003, (type 639) 2003 - 2014, (type 447) >2014

**GO** CODE **1366**  
 1 with 1 pcs. **kg** 0,11 kg

### Technical data

- length: 153 mm
- width: 78 mm

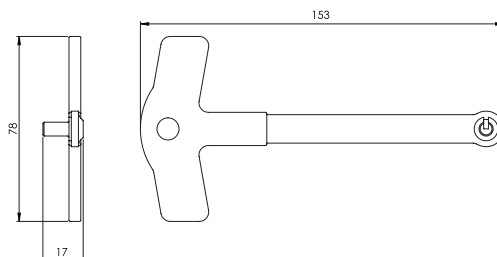



## WHEEL FIT UP BOLTS UNIVERSAL



- Easy fitting and mounting of wheels.
- Especially dedicated for cars with short axle tie free turning brake disc without centering screw.
- Just stick the bolts in to the wheel bolt bolts.
- Very quick mounting without any thread.
- For wheel bolts M12 and M14.

**Problem:** Brake disc VW-Group, without centering screw in the brake disc – free turning

**Problem:** Extremely short hub edge – Danger of falling wheel!

**Problem:** huge and heavy aluminium wheels



Hub edge

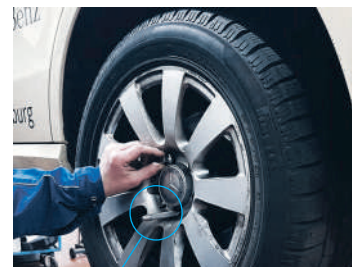

Pin for wheel support



**GO** CODE **038**

1 with 7 pcs. **kg** 0,3 kg

### Advantages

The full weight of the wheel is resting on the fit-up bolts.  
Easy centering and hands-free mounting of the wheel locking bolts.  
Very safe for the back of the mechanic, no risk of falling down of the heavy wheels.

### Components

- 1 x fit up bolt M12, L=127,5 mm
- 1 x fit up bolt M14, L=127,5 mm
- 2 x replacement sleeve M12, L=27,8 mm
- 2 x replacement sleeve M14, L=27,8 mm
- 1 x support, magnetic





## TORQUE MULTIPLIER 1:5, 1.500 Nm

**NEW**



### Components:

- 1 x 5:1 torque multiplier
- 2 x 3/4" socket wrench SW21 and 24

### Technical data

- Input torque: 300 Nm with 1/2' internal connection
- Output torque: 1,500 Nm with 3/4' external connection
- Weight of base unit: 3.850 kg
- Diameter of base unit: 100 mm

<b>GO</b>	CODE	<b>390</b>
<b>T</b>	with 3 pcs.	<b>Kg</b> 3 Kg

- This tool allows you to generate high torques for loosening and tightening with minimal effort and without the use of long and uncomfortable levers.
- The torque generated at the input is multiplied with a ratio of 5:1 at the instrument output.
- The basic device, compact and easy to handle, is versatile and can be used in the sectors of cars, vans, trucks, agriculture, construction machinery, etc.

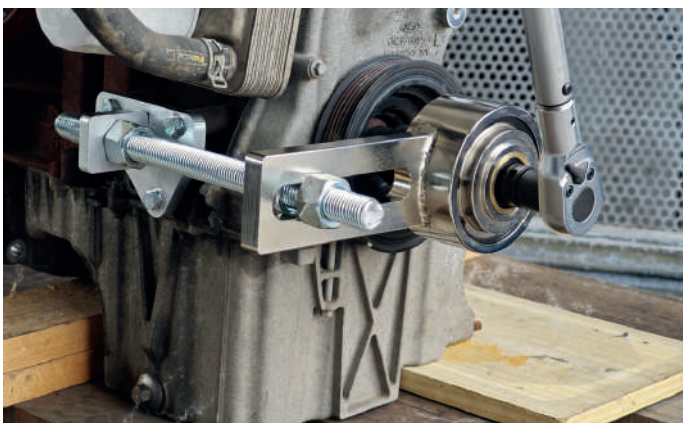
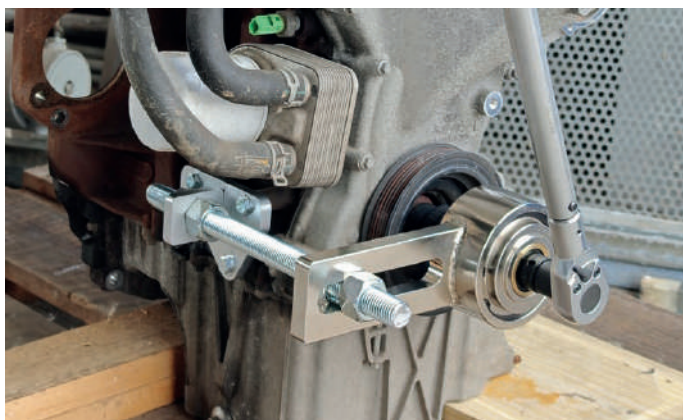

## + TIMING TOOL SET SUITABLE FOR FORD **NEW**



<b>GO</b>	CODE	<b>773</b>
<b>T</b>	with 21 pcs.	<b>Kg</b> 1,4 Kg

# ENGINE

INJECTORS AND GLOW PLUGS	<b>52-92</b>
ENGINE AND DISTRIBUTION	<b>93-106</b>
CLUTCH	<b>107-110</b>
TRANSMISSION	<b>111-115</b>
OIL SUMP AND FILTERS	<b>116-130</b>
RADIATOR AND AIR CONDITIONING	<b>131-133</b>
EXHAUST SYSTEM	<b>134-139</b>
CYLINDER HEAD AND ENGINE BLOCK	<b>140-148</b>
TIMING TOOLS	<b>149-182</b>



## INJECTOR EXTRACTOR MASTER KIT - BOSCH, DELPHI, DENSO, SIEMENS, CONTINENTAL



- Tool set designed to disassembly stuck Common Rail (CR) injectors. Composed by a universal bridge patented system, capable of adapting to the majority of engines on the market, as such adjustable in height, incline and extension.
- Designed in order to operate directly on the vehicle and in narrow spaces.
- The injector is removed from the cylinder head through the mechanical system with bearing.
- The 20 T hydraulic cylinder Art. **GO1020** or the mechadraulic cylinder Art. **GO1015** (not included), can be purchased in addition of this kit.
- It is possible to integrate this set with a vibration tool for the injector's extraction, Art. **GO490** (not included).



### INCLUDED:

Lubricating grease to be used with threaded bars, nuts etc...

**GO** CODE **405**  
 1 with 43 pcs. **kg** 21,3 kg  
 § **PATENTED**

Code	Thread	Description	Q.ty
311 146 011	M18x1.5	Screw L=220 mm	1
311 070 006	M18x1.5	Nut CH30	1
311 083 004		Washer with bearing	1
311 166 008	M-F M18x1.5	Extension	1
311 166 007	F-F M18x1.5	Extension	1
311 146 017	M27x1	Adapter (SIEMENS)	1
311 146 016	M25x1	Adapter (SIEMENS)	1
311 146 013	M14x1.5	Adapter (DELPHI)	1

Code	Thread	Description	Q.ty
311 146 014	M16x1	Adapter (DENSO)	1
311 146 015	M20x1	Adapter (DENSO)	1
311 166 005	Int. M17x1 - Ext. M27x1	Adapter (BOSCH)	1
311 198 000	Int. M14x1 - Ext. M25x1	Adapter (SIEMENS)	1
311 199 000	Int. M14x1 - Ext. M25x0,75	Adapter (DENSO)	1
311 210 000	Int. M20x1 - Ext. M25x0,5	Adapter (DENSO)	1



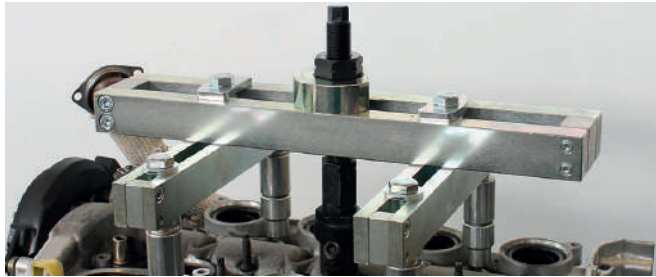

**Universal patented bridge system**

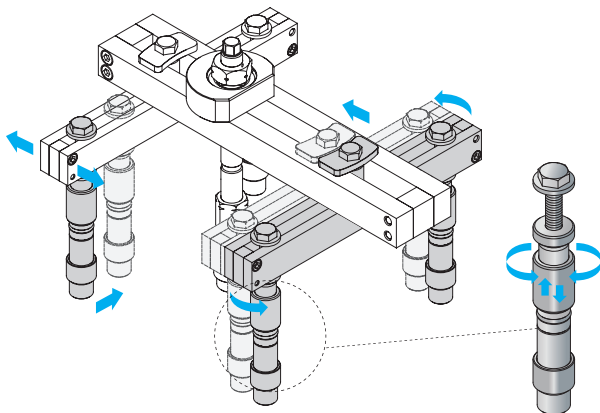

Cylinder not included.



Cylinder and Vibrofighter not included.



**Application**

Injectors: Bosch, Delphi, Denso, Siemens e Continental  
 Brand: Gruppo FCA, Citroen, Dacia, Ford, Mercedes, Nissan, Opel, Peugeot, Renault, Suzuki, Toyota , Volvo etc.

**+ 12T MECHADRAULIC CYLINDER ADAPTOR ALUMINIUM**



**Technical data**

- Force: 12 ton
- Stroke: 8 mm
- Dimensions: Ø80x260x45 mm
- Pressure: max. 700 Bar
- Hole: Ø21.5 mm
- Driving torque: 56 Nm
- Weight: 1,65 kg
- Grease temperature range of

use: from -25°C to 80°C

- Material: aluminium
- Adaptors: M10/M12/M14/M16/M18

**GO** CODE **1015**  
 with 8 pcs. **kg** 1,8 kg  
**§ PATENTED**

**+ 20T HYDRAULIC CYLINDER 8 MM, STEEL**



**Technical data**

- Dimensions: Ø100x60 mm
- Pressure: max. 700 Bar
- Hole: Ø33 mm

- Connection: 3/8" -18 NPT
- Adapter: Ø20 mm

**GOLOCK** HYDRAULIC  
**GO** CODE **1020**  
 with 2 pcs. **kg** 3 kg

**GOQUICK** HYDRAULIC  
**GO** CODE **1020Q**  
 with 2 pcs. **kg** 3 kg

# G BOSCH CR INJECTOR EXTRACTOR KIT - BASIC

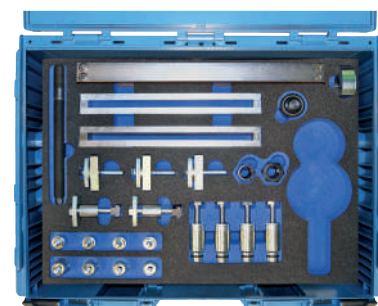

### INCLUDED:

Lubricating grease to be used with threaded bars, nuts etc...

### Application

The set allows you to adapt about 90% of all injectors.

- This set is required as a base for traditional injector disassembly tools, such as the slide hammer or the injector bridge.
- It contains all the tools needed to breakdown the piece and the adapters for screws needed for connection to the disassembly system available.
- In this way the injectors can then be extracted with high impact and hydraulic forces.

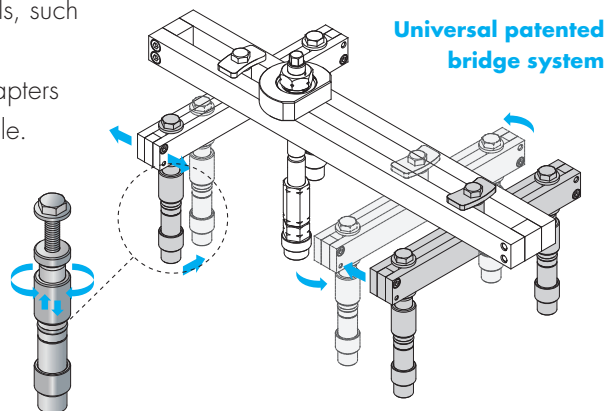

Universal patented bridge system

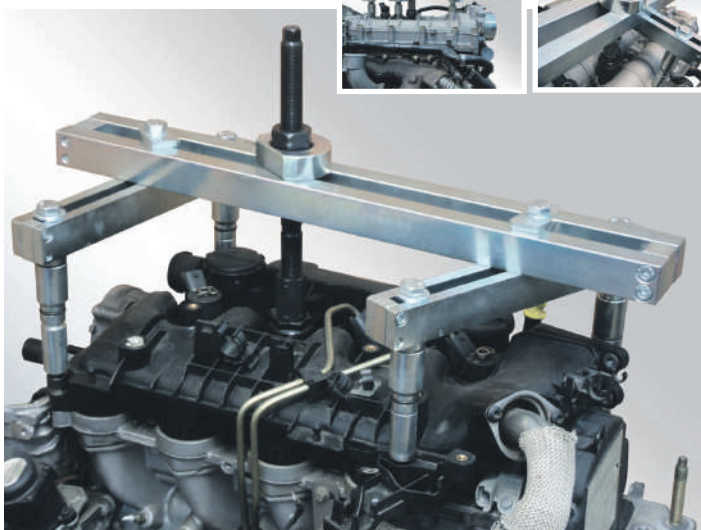

## + INJECTOR ADAPTOR SET - BOSCH

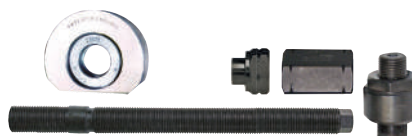

### Components

- 1 x Screw M18x1.5 L=220 mm
- 1 x Washer with bearing
- 1 x Extension FF M18x1.5
- 1 x Adapter Int. M17x1 - Ext. M27x1 (BOSCH)
- 1 x Nut M18x1.5 - CH30

- Integrative set for the extraction of Bosch CR injector.
- For engines where it is necessary a double and simultaneous extraction of the injectors.

**GO** CODE **414**  
with 26 pcs. **kg** 12 kg  
§ **PATENTED**

**GO** CODE **421**  
with 5 pcs. **kg** 1,4 kg



## "VIBROFIGHTER" UNIVERSAL VIBRATION TOOL



### Technical data

- CE approved machine in compliance with 2006/42/CE (Machine Directive)
- Working pressure: 6.2bar
- For tie rod min. Ø10 mm - max Ø25 mm

AIR CONSUMPTION		
	Dry cycle consumption	Charge cycle consumption
m <sup>3</sup> /h	0,18	at max opening 0,13 at minimum opening 0,05
lt/min	3.00	at max opening 2,17 at minimum opening 0,83

- It releases very seized injectors, due to carbonization and rust, without damaging the cylinder head and without breaking the injector, which would leave residues inside the head. Can be used on any injector extraction set.
- When this tool is used, it acts directly on the removal tie rod, which is dynamically coupled with the injector, through vibrations and pulses.

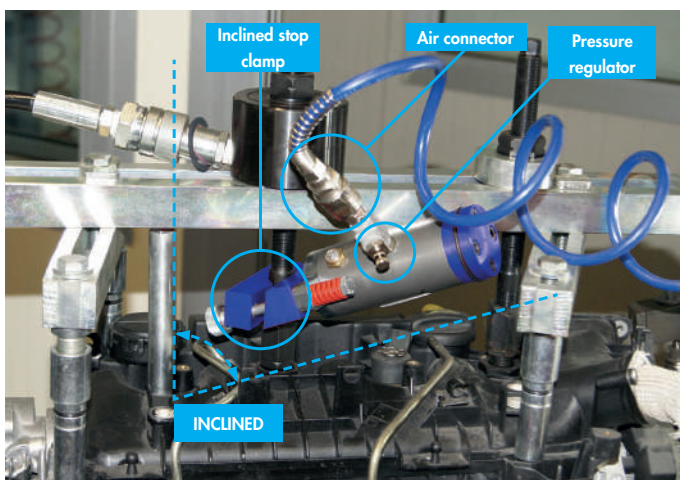

**GO** CODE **490**  
 with 6 pcs. 3 kg  
 § **PATENTED**



## INJECTOR EXTRACTOR KIT MASTER - BOSCH, DELPHI, DENSO



- Specific for disassembling very stuck injectors.
- The universal supporting feet adjustment, on the fixing screws of the head, ensures its use in different levels (l/r) as well as the possibility to adjust the slippage of the two side bars.

**GO** CODE **405**  
 with 43 pcs. 21,3 kg  
 § **PATENTED**



## + 12T MECHADRAULIC CYLINDER STEEL



### Technical data

- Hole: Ø21.5 mm
- Stroke: 8 mm
- Dimensions: Ø80x55 mm
- Driving torque: 56 Nm
- Material: aluminium
- Working independent without pump!



**GO** HYDRAULIC CODE **1010**  
with 1 pcs. 2,5 kg

## + 12T HYDRAULIC CYLINDER 8 mm, STEEL



### Technical data

- Dimensions: Ø80x55 mm
- Pressure: max. 700 Bar
- Hole: Ø21.5 mm
- Connection: 3/8" -18 NPT

**GO** LOCK HYDRAULIC CODE **1012**  
with 1 pcs. 2 kg

**GO** QUICK HYDRAULIC CODE **1012Q**  
with 1 pcs. 2 kg

## + 20T HYDRAULIC CYLINDER 8 mm, STEEL



### Technical data

- Dimensions: Ø100x60 mm
- Pressure: max. 700 Bar
- Hole: Ø33 mm
- Connection: 3/8" -18 NPT
- Adapter: Ø20 mm

**GO** LOCK HYDRAULIC CODE **1020**  
with 2 pcs. 3 kg

**GO** QUICK HYDRAULIC CODE **1020Q**  
with 2 pcs. 3 kg

## + HYDRAULIC ALUMINIUM PUMP - HAND OPERATED 700 BAR, ALUMINIUM

### Technical data

- Maximum working pressure: 700 bar
- Speed/stroke: single
- Oil tank volume: 700 cm<sup>3</sup>
- Oil volume per stroke: 500 cm<sup>3</sup>
- Oil displacement per stroke: 1.8 cm<sup>3</sup>
- Max effort on the handle to 700 bar: 46 kg
- Piston stroke: 24 mm
- Øpiston: 10 mm
- Connection: 3/8" NPT
- Hose length: 1.8 mt



**GO** LOCK HYDRAULIC CODE **1030**  
with 1 pcs. 4,7 kg

**GO** QUICK HYDRAULIC CODE **1030Q**  
with 1 pcs. 4,7 kg

**G RETURN HOSE DISASSEMBLY TOOL DIESEL, VW GROUP**



- Designed for actuating the round connector on the fuel return line connector of the injector.
- Guarantees fast and damage-free detaching and plugging in of the quick coupling.
- This tool is required because if the connection coupling is not properly disassembled, it can be damaged, which results in the replacement of the complete fuel return line.

**Application**

<b>VW</b>	EOS, Golf V, VI, Jetta, Passat, Passat CC, Scirocco, Tiguan, T5-Phaeton
<b>AUDI</b>	A3, A4, A5, A6, A7, Q5
<b>SKODA</b>	Yeti
<b>SEAT</b>	Exeo

**Engine:** TDI CR, blue TDI CR, TDI CR BlueMotion, TDI CR BlueMotion technology, TDI (from 2004-2015)

**Engine code:** **2.0:** CAAA, CAAB, CAAC, CAAD, CAAE, CAGA, CAGB, CAGC, CBAA, CBAB, CBAC, CBDA, CBD, CBDC / **2.7:** BPP / **3.0:** CDUD, BMK

**Other uses:** Leaking oil lines OE-5801506923 / Iveco Daily 2.3L and 3.0L with piezo injector from 03.2014

**GO** CODE **515**  
 1 with 1 pcs. kg 0,2 kg



**Technical data**  
 • Length: 100 mm



**G RETURN HOSE DISASSEMBLY TOOL TYP2 DIESEL, VW GROUP**



- Designed for actuating the round connector on the fuel return line connector of the injector.
- Guarantees fast and damage-free detaching and plugging in of the quick coupling.
- This tool is required because if the connection coupling is not properly disassembled, it can be damaged, which results in the replacement of the complete fuel return line.

**Application**

<b>VW</b>	T6, Multivan VI, Caddy, Crafter 2,0 TDI, Golf 7, Sportsvan, Tiguan
<b>AUDI</b>	A3, Q2, Q3
<b>SKODA</b>	Oktavia III, Yeti, Karoq, Kodiaq
<b>SEAT</b>	Leon, Toledo, Ateca

**Engine:** **1.6:** TDI and 4motion 81 KW and 85 KW with Delphi injection system from 06.2013 / **2.0:** TDI and 4motion 62 KW and 110 KW with Delphi injection system from 04.2015

**Engine code:** **1.6:** CXX, CXXB, DDY, DDYA, DDYB, DGTE, DBKA / **2.0:** CXF, CXFA, CXG, CXGA, CXH, CXHA

**GO** CODE **533**  
 1 with 1 pcs. kg 0,2 kg



**Technical data**  
 • Length: 100 mm

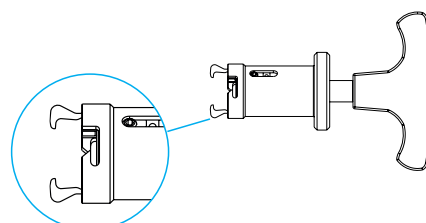



## INJECTOR EXTRACTOR KIT - M9R 2.0 RENAULT, NISSAN, OPEL - 12T



- Kit for the removal of injectors mounted on Renault, Nissan and Opel 2.0 diesel engines, engine code M9R.
- Designed to extract the injectors in one of the following ways:
  1. Extraction of the injector with electrical connector.
  2. Extraction of the injector without electrical connector.
  3. Extraction of the broken injector.

**+** **INCLUDED:**  
Mechadraulic cylinder 12 ton

### Application

Renault, Nissan, Opel  
Motor 2.0 diesel - Engine code M9R

### Injectors

Bosch CR, Bosch Piezo

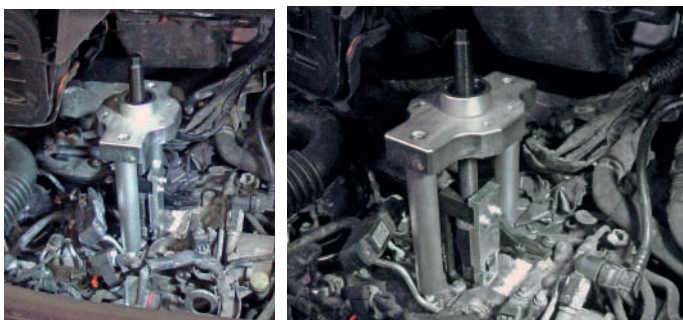

### Technical data (Mechadraulic cylinder)

- Force: 12 ton
- Stroke: 8 mm
- Dimensions: Ø80x260x45 mm
- Pressure: max. 700 Bar
- Hole: Ø21,5 mm

- Driving torque: 56 Nm
- Weight: 1,65 kg
- Grease temperature range of use: from -25°C to 80°C
- Material: aluminium
- Adaptors: M10/M12/M14/M16/M18

**GO** CODE **537**  
 with 43 pcs. 13,5 kg  
**§ PATENTED**





## INJECTOR EXTRACTOR KIT - 12T, MERCEDES



- This kit allows the removal of the tightly fixed injectors nozzles mounted on MERCEDES 2.1 L, 2.2 L, 3.0 V6 and 3.0 V6 and CHRYSLER 3.0 V6.
- Significant time saving in terms of complete procedure, avoiding the removal of the cylinder head the engine or even worse, removal.
- Professional and convenient job, thanks to the 12 ton go-through cylinder of the "Invisible" series by Govoni.



### Application

Injectors: Delphi, Bosch  
 Chrysler: 300 C  
 Mercedes: Vito, CLK, Sprinter,  
 Viano, Vario, Classe M, GL, C,  
 GLK, E, CLS, S, R, G  
 Engines: CDI 2.1 L, 2.2 L, 3.0  
 V6

### Technical data (Mechadraulic cylinder)

- Force: 12 ton
- Stroke: 8 mm
- Dimensions: Ø80x260x45 mm
- Pressure: max. 700 Bar
- Driving torque: 56 Nm
- Hole: Ø7 mm
- Adaptors: M10/M12/M14/M16/M18
- Weight: 1,65 kg
- Grease temperature range of use: from -25°C to 80°C
- Material: aluminium



### Assembly 1

Extractor operation for 4- and 5-cylinder engine



### BOSCH CR



### Assembly 2

Extractor operation for 6-cylinder engine



### DELPHI PIEZO



### INCLUDED:

Mechadraulic  
 cylinder 12 ton



CODE

**402**

1 with 10 pcs.

kg 4,8 kg

§ **PATENTED**



## INJECTOR EXTRACTOR KIT - MERCEDES



### Assembly 1

Extractor for engines 4 - 5 cylinders



### Assembly 2

Extractor for engines 6 cylinders

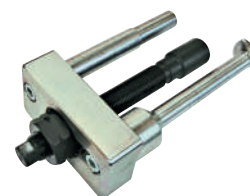

- This kit allows the removal of the tightly fixed injectors nozzles and the removal of all the injectors mounted on MB 2.1 L, 2.2 L, 3.0 V6 without dismounting the cylinder head.

#### Operating the extractor on engines with 4 and 5 cylinders

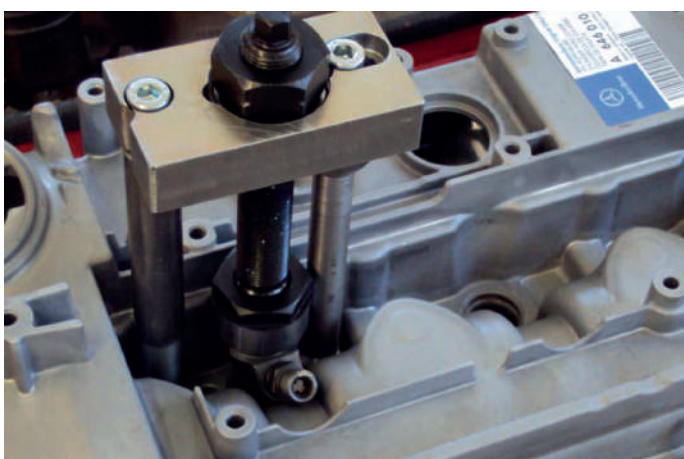

#### Operating the extractor on engines with 6 cylinders



#### Application

Injectors: Bosch, Delphi  
 Engines: 2.1 l, 2.2 l, 3.0 V6

Chrysler: 300 C  
 Mercedes: Vito, Vario, CLK, Sprinter,  
 Viano, Classe M, GL, C, GLK, E,  
 CLS, S, R, G



<b>GO</b>	CODE	<b>425</b>
<b>1</b>	with 7 pcs.	<b>kg</b> 3 kg

## **G** BOSCH CR REMOVAL SOCKET



### Application

The socket holds the injector under the fixing nut of the electrical connection

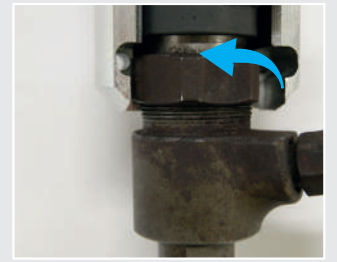

- Special socket that allows removal of bosch injectors both with size CH.29 and CH.30. The tool allows the removal of the complete injector granting no injector opening/dismounting.
- The tools ensures the removal of the injector without removing the electrical connection plastic top.

<b>GO</b>	CODE	<b>441</b>
<b>1</b>	with 1 pcs.	<b>kg</b> 0,7 kg
<b>§ PATENTED</b>		

## **G** INJECTOR EXTRACTOR RENAULT, NISSAN, OPEL PIEZO

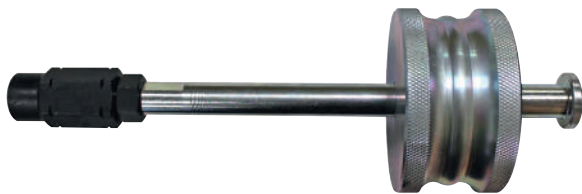

### Application

Renault, Nissan, Opel and other manufacturers' diesel engines

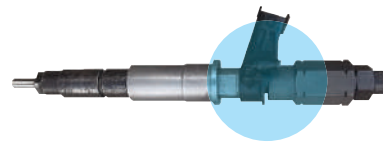

- Complete tool for removing piezoelectric injectors with M14 injection line socket.
- Good impact applied with elevated loosening effect.
- Loosen about 80% of all stuck injectors. This allows a significant saving in terms of time and cost, avoiding, where possible, the risk of sending the injectors to be rectified.



<b>GO</b>	CODE	<b>559</b>
<b>1</b>	with 3 pcs.	<b>kg</b> 1,8 kg

## **G** BOSCH INJECTOR EXTRACTOR



- Complete tool for removing Bosch magnetic injectors.
- The extraction occurs without disassembling the electrical connection and thus guarantees the reuse of the injector without having to re-calibrate it.



### Application

Universal for diesel engines of many manufacturers



It is recommended to use the item with the sliding hammer NOT EXCEEDING 1.5KG

<b>GO</b>	CODE	<b>543</b>
<b>1</b>	with 3 pcs.	<b>kg</b> 1,8 kg
<b>§ PATENTED</b>		



## **G** SLIDE HAMMER INJECTOR SET WITH CR ADAPTERS SIEMENS, BOSCH, DENSO



**GO** CODE **449**  
1 with 9 pcs. 5 kg



## **G** MASTER SLIDE HAMMER INJECTOR SET WITH CR ADAPTERS SIEMENS, BOSCH, DENSO



**GO** CODE **507**  
1 with 11 pcs. 5 kg  
§ **PATENTED**



- New adapters M12x1.5 and M14x1.5 for CR connector.
- Extractor for injectors for professional mechanics, car-repair garages or car repair shops. This operation may be carried out without disassembling the injector head.
- This kit allows injector removal with three distinct procedures:

- 1** Using the pliers with holding arms perfectly fitting to the shape of the injector.
- 2** Using the articulated joint adapter and the pivot, that has to be screwed to the fitting of the Common Rail duct.
- 3** Use on Pump Düse injectors.

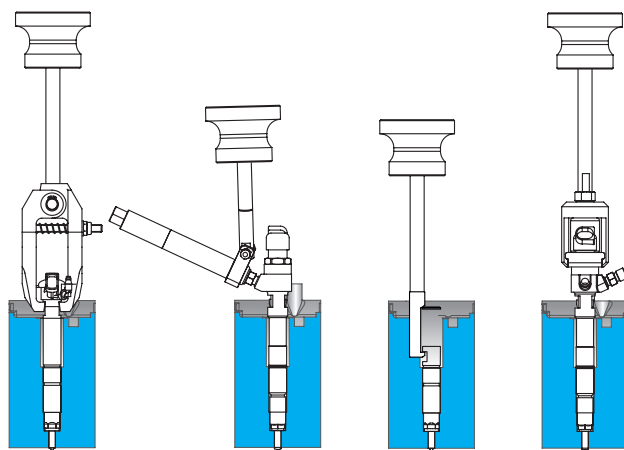

CASE 1

CASE 2

CASE 3

CASE 4

- Complete selection for extracting injectors without dismantling them through slide hammer.
- The set offers 4 different solutions, depending on the injector's types and characteristics:
  - 1** Pliers for lateral fixing of the injector.
  - 2** M12x1.5 and M14x1,5 adapters, in order to fix to the Common Rail duct.
  - 3** Adapter for extracting Pumpe Düse injectors.
  - 4** Special socket for Bosch CR (CH29-CH30 mm).



## SLIDE HAMMER INJECTOR REMOVAL SET - DENSO



- System studied to remove injectors independently from the engines, where they are mounted.
- Different types of tools (modular) to be fixed to the injector to be extracted.
- Carry out the removal operation by connecting the extractors to injector edges, it is therefore not necessary to disassemble the upper part of it and this guarantees ist operation.
- Group for the extraction of the injectors with the aid of the slide hammer.



### Assembly

DENSO  
23670-26011

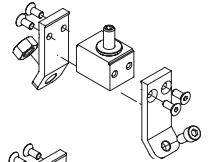

DENSO  
23670-30080  
08G09496  
23670- 0R050  
10J 06798

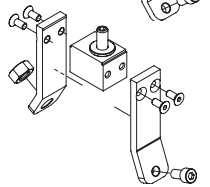

DENSO  
MB4 16600  
MB40A 03J  
01523

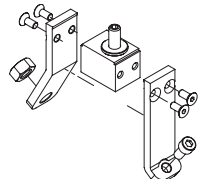

DENSO  
5870 09F03391  
13H50B

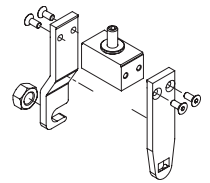

DENSO  
8-97376270-3  
11L 12182

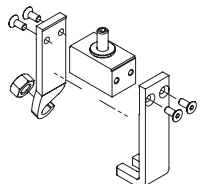

DENSO  
6C1Q-9K546-BB  
09H 05699

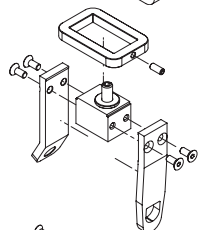

DENSO  
8-97376270-1  
02K 26779

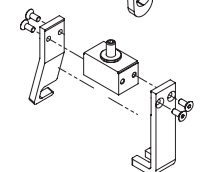

**GO** CODE **403**  
with 15 pcs. **kg** 7,3 kg



### Application

Injectors code: 23670 - 30080, MB416600 - MB40A, 5870 - 13H50B  
Denso: 11L 12182, 23670 - 26011, 23670 - 0R050, 10J  
Brand: Toyota, Lexus, Nissan, Mazda, Opel/Vauxhall



## INJECTOR SET FOR FORD 2.0 ECOBLUE TDCI



- Set of special tools to remove FORD 2.0 ECOBLUE TDCI injectors (from 2016).
- Solution designed to remove highly blocked injectors in a professional, safe and fast way:
  1. Complete extraction of the injector (no dismantled).
  2. Broken injector extraction.
- In the case that the injector breaks during the extraction, it is possible to use the tools included in the set to extract the remaining parts of the injector.

Example of use

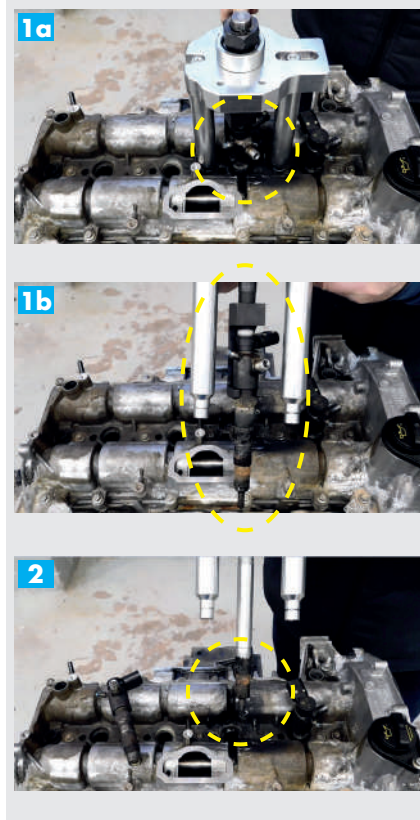

### + INJECTOR REMOVAL SOCKET 2.0 ECOBLUE TDCI, FORD



#### Application

Ford 2.0 ecoblue TDCI from 2016 (Ford Galaxy, S-max, Mondeo, Focus C-Max, Transit and Custom (from 2018) etc

#### Engine code

YLF6, YLF6, YMFS, YMF6, YNF6, YNF6, YLR6, YMR6, YNR6



Brand	Model	Engine	Engine code
FORD	Galaxy	2.0 EcoBlue TDCi (from 2016)	YLF6 (77Kw),
	S-Max		YLF6 (77Kw),
	Mondeo		YMFS (96Kw),
	Focus		YMF6 (96Kw),
	C-Max		YNFS (125Kw),
	Transit		YNF6 (125 Kw),
	Transit Custom		YLR6 (77 Kw),
	Tourneo Custom		YMR6 (96 Kw),
			YNR6 (125 Kw)

**GO** CODE **434**  
1 with 17 pcs. 6,5 kg

**GO** CODE **519**  
1 with 1 pcs. 0,6 kg





## INJECTOR NOZZLE RESTORER

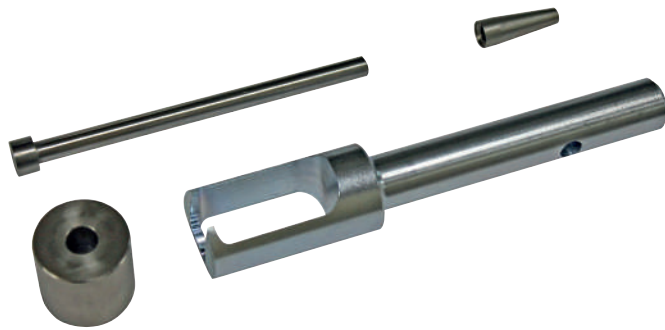

- To dismantle petrol injectors and to install the Teflon gasket
- For restoring fuel injectors immediately after calibration of the sealing rings. Puller fork with hole for sliding handle (6 mm) and M8 female thread for slide hammer (not included)

### APPLICATION:

#### Models

S-Class S550, CL-Class CL550, S-Class Coupe/Cabriolet S550, CLS-Class CLS550, SL-Class SL550, E-Class E550, M-Class GLE-Class GL450, GL-Class GLS-Class GL550, GLS550, S63 AMG, CL63 AMG. G, CLS 63 AMG, ML 63 AMG, GLE 63 AMG, GL 63 AMG, GLS 63 AMG, E63 AMG, Infiniti Q50 (2.0t), Q60 (2.0t) & QX30 (2.0t)

#### Engine

Suitable for most Mercedes 4.6 and 5.5L petrol engines

#### Engine code

M133, M152, M157, M270, M274, M276, M278

#### to be used as injectors

278 589 00 33 00

272 589 00 43 00



CODE **564**



with 4 pcs.



0,3 kg



### Components

1 x injector nozzle removal

1 x mounting sleeve

1 x mounting cone



## BOSCH INJECTOR PULLER M18X1,5



- Complete tool for the removal of Bosch magnetic injectors.
- The half-shells of the tool head are positioned directly under the screw ring of the injector electrical connection. The locking sleeve with window provides a non-slip grip.
- Removal is carried out without partial disassembly and this ensures that the injector can be reused.

### Application

Universal for diesel engines of many manufacturers

### Technical data

- Connection internal thread M18x1.5



CODE **563**



with 4 pcs.



3 kg



## ADAPTER FOR BOSCH INJECTOR SOLENOID VALVE M18X1.5



- To be used with Govoni 1.4 to 3.0 kg slide hammer.



CODE **562**



with 1 pcs.



0,92 kg

## G INJECTOR REMOVAL KIT FOR BOSCH DUCATO DIESEL ENGINE 3.0



- Complete tool for the removal of Bosch piezo injectors.
- The injector is held firmly on the injection line thread and in the clamping claw support and it is pulled out with a slide hammer.
- Removal is carried out without partial disassembly and this ensures that the injector can be reused.

**GO** CODE **561**  
with 4 pcs. **kg** 2 kg

**Application**  
**Fiat Ducato**  
3.0 L Diesel from 2006  
**Iveco Daily**

2.3 L from 2011 to 2014  
3.0 L Diesel from 2007  
**Citroen Jumper**  
3.0 L HDI from 2010

**Peugeot Boxer**  
3.0 L HDI from 2010

**Injectors**  
0445116059  
0445116019

## G PETROL INJECTOR REMOVAL SLIDE HAMMER FORD, OPEL, BOSCH GDI



- For pulling out Bosch GDI petrol injectors without partial dismantling or damage.
- The two-part tool design ensures a secure hold on the injector.
- The supplied slide hammer guarantees high tensile forces!



**GO** CODE **532**  
with 5 pcs. **kg** 0,2 kg

**Technical data**

- Impact weight 1,4 kg
- Total length 250 mm

## G FORD INJECTOR EXTRACTOR



- Complete tool for the removal of the injectors on Ford 2,0 Eco Blue engines.
- Loosens about 80% of all stuck injectors without disassembling the electrical connection.
- The fork seizes directly where the locking claw fixes also the injector.
- This simple and effective solution is not offered by OEMs and therefore becomes an essential optional to the OEM tool for removing the Ford 2.0 Eco Blue injectors, allowing the mechanic a quick intervention and an evaluation of the necessary operation costs.



**GO** CODE **560**  
with 3 pcs. **kg** 1,8 kg

**Application**  
Universal for diesel engines of many manufacturers

**G** **SLIDE HAMMER - 9 KG**



- For powerfully releasing components and for bodywork straightening jobs.
- Extremely effective loosening effect via impact with a maximum force of approx. 8 ton.
- It loosens even the most firmly seized or rusty components, or connected with a cone.
- With the relevant accessories, suitable for removing injectors, wheel hubs, supporting joints etc.



**GO** CODE **520**  
 T with 1 pcs. kg 11,6 kg

**Technical data**

- Slide hammer with weight: 9 kg
- Total length: 770 mm
- Connection thread: M18x1.5

**G** **SLIDE HAMMER 9KG, DEAD BLOW**

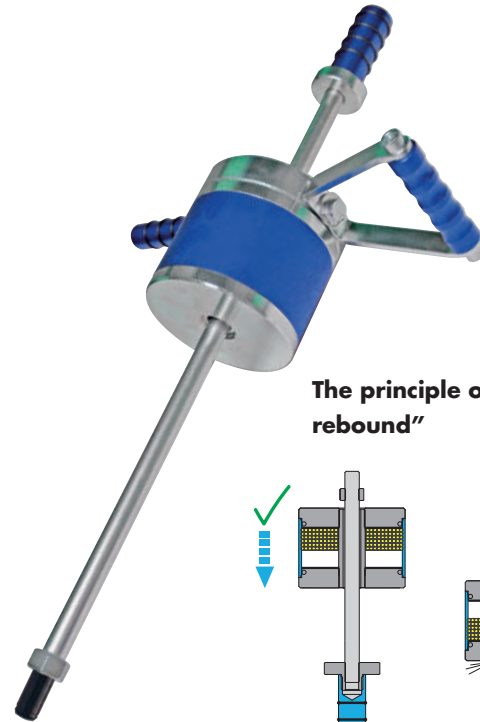

**The principle of "no-rebound"**

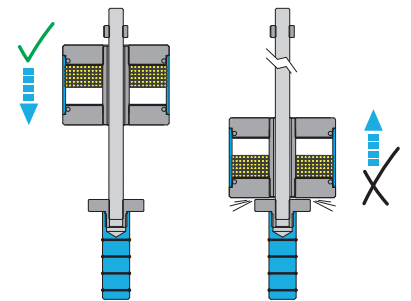

- For powerful expulsion of stuck components as well as for body straightening work.
- The new slide hammer version is filled with a steel shot. This prevents the weight from bouncing back against the abutment. The impact intensity is thus increased because the full impact force is transmitted to the component to be machined.
- This version is also very gentle on the joints and allows fatigue-free working.



**GO** CODE **530**  
 T with 2 pcs. kg 11 kg  
 § **PATENTED**



## + THREAD ADAPTERS SET

- Complementary assortment containing the four most commonly used adapters for slide hammers code **GO520** and **GO530**.



### Components and applications

1 x adapter, M18x1.5 for universal hooks/double extractor hooks/ bow hooks/bodywork pull clamps etc., suitable e.g. for the systems: Gmelin-Moll/Müller/Klann/KS/Kukko/ Pichler/Sauer/Sykes-Pickavant etc.

1 x adapter, M18x1.5/1-1/2 inch x 16 for wheel hub puller. Suitable e.g. for the systems: Würth Müller/KS/Sauer/Pichler/Kukko/BGS etc.

1 x adapter with ball joint, M18x1.5/ M18x1.5, for use between the slide hammer and the tool - enables work in hard-to-reach places - suitable for all systems

1 x adapter, M18x1.5/M22x2, for wheel hub puller, suitable e.g. for the following systems: Würth/ Facom

## + M18x1,5 ADAPTER

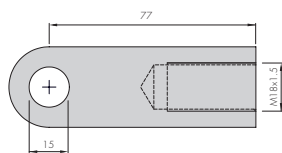

### Application

Suitable e.g. for the following systems: Müller, Klann, Ks, Kukko, Pichler, Sauer, etc.

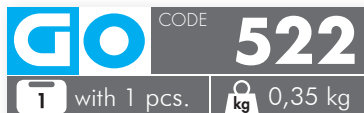

## + M18 - 1 1/2 UN16 ADAPTER

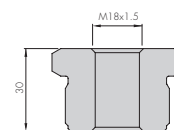

### Application

Suitable e.g. for the following systems: Müller, Ks, Kukko, Pichler, Sauer, BGS, etc.



## + M22x2 - M18x1,5 ADAPTER

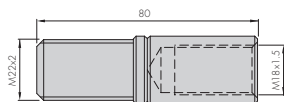

### Application

Suitable e.g. for the following systems: Würth, Facom.

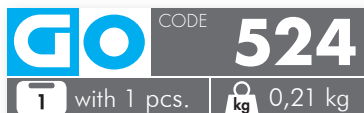

## + M18x1,5 - M18x1,5 ADAPTER

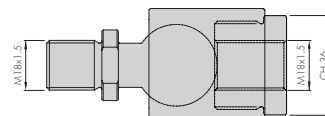

### Application

Suitable for all systems.





## SLIDE HAMMER REMOVAL - ADVANCED KIT

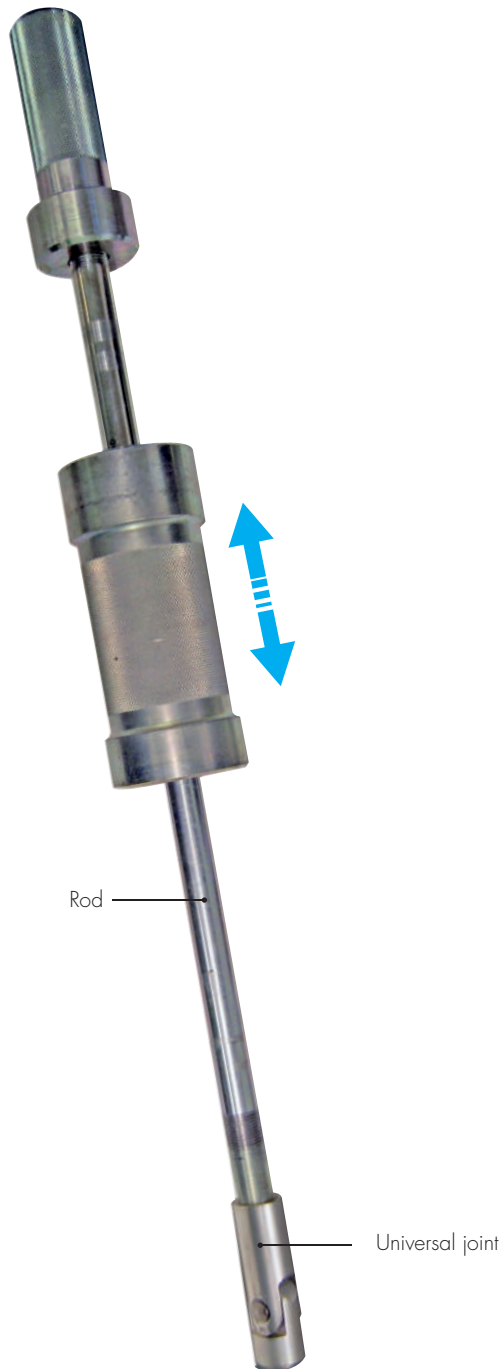

### Example of application



- This basic set is part of a modular system and serves as a drive tool for various extractors. It saves money, as it only has to be purchased once.
- Use together with injector disassembly tools.
- M18 support thread allows direct activation of injector extraction brackets (without breakdown of the piece) and also of injector-extractor-thread adapters (with breakdown of the piece).
- Depending on the space and strength requirements, the sliding rod can be extended and/or equipped with a joint.

### Technical data

- Slide hammer: 3 kg

<b>GO</b>	CODE	<b>407</b>
<b>1</b>	with 10 pcs.	<b>kg</b> 6,2 kg

**G** **SLIDE HAMMER NON-IMPACT - 3 KG UNIVERSAL**



- For powerful expulsion of stuck components as well as for body straightening work. The new slide hammer version is filled with a steel shot. This prevents the weight from bouncing back against the abutment.
- The impact intensity is thus increased because the full impact force is transmitted to the component to be machined.
- This version is also very gentle on the joints and allows fatigue-free working.



**Technical data**

- slide hammer 3 kg
- two-piece adjustable rod  
L = 580 mm
- thread rod M18x1.5
- adaptor M18x1.5
- cardan joint M18x1.5
- screw and washer

**THE PRINCIPLE OF "NON-IMPACT"**

Anti-rebound metal balls increase the impact force, which is transmitted entirely to the part to be removed.

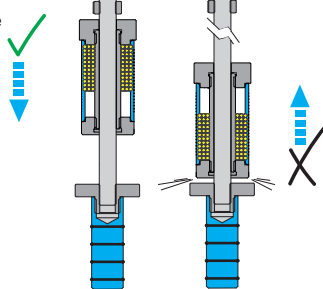

**GO** CODE **438**  
with 10 pcs. 7,5 kg  
**§ PATENTED**

**G** **DOUBLE CONE BEARING REMOVAL KIT UNIVERSAL**

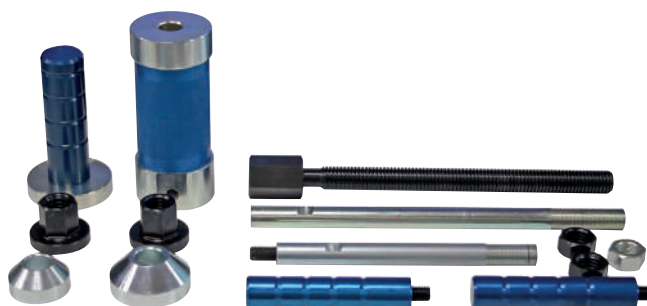

- For the quick removal of wheel hubs and bolted wheel bearings.
- Simple and efficient method to remove front wheel hubs quickly and without too much effort in terms of assembly.

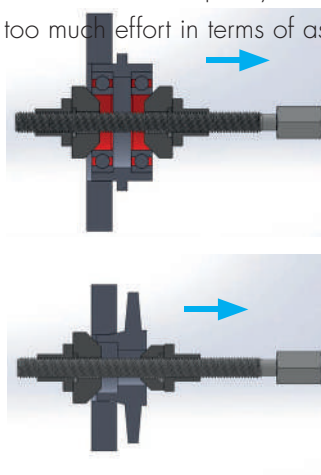

**Application**

Injectors, hubs, support joints, bodywork works

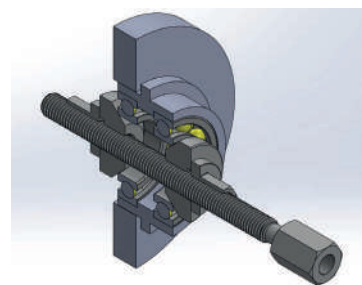

**GO** CODE **439**  
with 14 pcs. 10 kg





## SLIDE HAMMER REMOVAL - STANDARD KIT



### Example of applications



- This basic set is part of a modular system and serves as a drive tool for various extractors. It saves money, as it only has to be purchased once.
- Use together with disassembly tools for glow plugs and injectors.
- With the help of various adapters, it is possible to directly activate injector extraction fasteners, disassembly tool sealing rings and extraction spindles.
- Depending on the space and strength requirements, the sliding rod can be extended and/or equipped with a joint.

Use with screw in adaptors



Use with fork adaptors

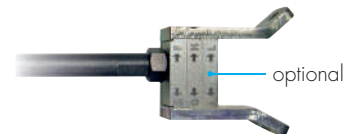

Universal joint

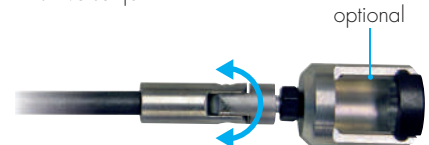

## + UNIVERSAL ADJUSTABLE PLIER



- Special claw to take the injector fitted.
- M12 connection.

**GO** CODE **454**  
 with 1 pcs. 0,3 kg

**Technical data**  
 • Slide hammer: 1,5 kg

**GO** CODE **406**  
 with 8 pcs. 2 kg

## INJECTOR REMOVAL FORK MERCEDES



### Application

Mercedes CDI engines (except for Sprinter / Vito and A Class)

### Technical data

- Fork width: 12 mm
- Connection thread: M18x1.5

<b>GO</b>	CODE	<b>424</b>
<b>1</b>	with 1 pcs.	<b>kg</b> 0,4 kg

## INJECTOR REMOVAL FORK FORD



### Application

Ford 2.0 ecoblue TDCI from 2016 (Ford Galaxy, S-max, Mondeo, Focus C-Max, Transit and Custom (from 2018) etc

### Technical data

- Fork width: 19 mm
- Connection thread: M18x1.5
- Height: 98 mm

<b>GO</b>	CODE	<b>455</b>
<b>1</b>	with 1 pcs.	<b>kg</b> 0,3 kg

## M9R 2.0 DCI INJECTOR EXTRACTOR CLAMP NISSAN, RENAULT, BOSCH PIEZO

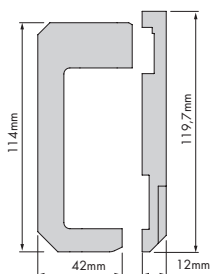
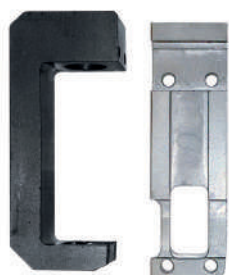

### Application

Renault/Nissan, Opel 2.0 dCi  
Engine code: M9R

### Components

- 1 x M9R injector extractor
- 1 x M9R injector extractor plate
- 2 x washer 5x10
- 2 x screw M5x16

<b>GO</b>	CODE	<b>469</b>
<b>1</b>	with 6 pcs.	<b>kg</b> 0,8 kg
<b>§</b>	<b>PATENTED</b>	

## INJECTOR REMOVAL FORK SIEMENS



### Components

- 1 x fork
- 1 x adaptor M25x1
- 1 x fixing nut

### Technical data

- Fork width: 14 mm
- Connection thread: M18x1.5
- Height: 104 mm

<b>GO</b>	CODE	<b>442</b>
<b>1</b>	with 3 pcs.	<b>kg</b> 0,5 kg

## INJECTOR REMOVAL FORK FIAT, OPEL



### Application

Opel: 1.9L (Z19DT, DTH, DTL)  
Opel: 2.0L (LBS, LBX, LBY, LCD) e.g.  
Insignia  
Fiat: 1.9L JTD

### Technical data

- Fork width: 25 mm
- Connection thread: M18x1.5

<b>GO</b>	CODE	<b>423</b>
<b>1</b>	with 1 pcs.	<b>kg</b> 0,4 kg

## INJECTOR REMOVAL FORK DELPHI

### Components

- 1 x fork
- 1 x adaptor M18x1.5 - M12

### Technical data

- Fork width: 16 mm
- Connection thread: M18x1.5
- Height: 70 mm

<b>GO</b>	CODE	<b>443</b>
<b>1</b>	with 2 pcs.	<b>kg</b> 0,4 kg

## INJECTOR REMOVAL FORK BOSCH



### Technical data

- Fork width: 16 mm
- Connection thread: M18x1.5
- Height: 129 mm

<b>GO</b>	CODE	<b>444</b>
<b>1</b>	with 1 pcs.	<b>kg</b> 0,4 kg

**+ INJECTOR ADAPTOR SET  
DELPHI, DENSO, BOSCH, SIEMENS**

- The disassembling screw adapter helps to create a stressed, forcecoupled connection between the injector and the sliding rod or the glow plug. In this way the extractors can be extracted with high impact and hydraulic forces.
- The double adapters are simultaneously adjusted internally on the screwing ring thread and externally on the screwing of the nozzle head. The accessory allows connection with the traction systems available.



CODE	THREAD	DESCRIPTION	QUANTITY
311 146 011	<b>M18x1.5</b>	Screw L=220 mm	1 pcs.
311 070 006	<b>M18x1.5</b>	Nut CH30	1 pcs.
311 083 004		Washer with bearing	1 pcs.
311 166 008	<b>M-F M18x1.5</b>	Extension	1 pcs.
311 166 007	<b>F-F M18x1.5</b>	Extension	1 pcs.
311 146 017	<b>M27x1</b>	Adapter (SIEMENS)	1 pcs.
311 146 016	<b>M25x1</b>	Adapter (SIEMENS)	1 pcs.
311 146 013	<b>M14x1.5</b>	Adapter (DELPHI)	1 pcs.
311 146 014	<b>M16x1</b>	Adapter (DENSO)	1 pcs.
311 146 015	<b>M20x1</b>	Adapter (DENSO)	1 pcs.
311 166 005	<b>Int. M17x1 - Ext. M27x1</b>	Adapter (BOSCH)	1 pcs.
311 198 000	<b>Int. M14x1 - Ext. M25x1</b>	Adapter (SIEMENS)	1 pcs.
311 199 000	<b>Int. M14x1 - Ext. M25x0,75</b>	Adapter (DENSO)	1 pcs.
311 210 000	<b>Int. M20x1 - Ext. M25x0,5</b>	Adapter (DENSO)	1 pcs.



**Application**

The set allows you to adapt about 90% of all injectors.

**GO** CODE **427**  
1 with 14 pcs. **kg** 3,2 kg

**G INJECTOR REMOVAL SOCKET  
2.0 ECOBLUE TDCI, FORD**



**Application**

Ford 2.0 ecoblue TDCI from 2016 (Ford Galaxy, S-max, Mondeo, Focus C-Max, Transit and Custom (from 2018) etc

**Engine code**

Y1FS, Y1F6, Y1F5, Y1F6, Y1NF5, Y1NF6, Y1R6, Y1MR6, Y1NR6

**GO** CODE **519**  
1 with 1 pcs. **kg** 0,6 kg



## **G** BOSCH CR SOLENOID REMOVER

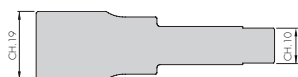

### Technical data

- CH.10 mm
- CH.19 mm



**GO** CODE **411**  
1 with 1 pcs. **kg** 0,2 kg

## **G** BOSCH CR ADAPTOR

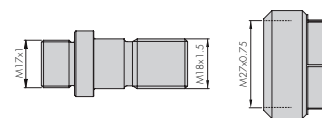

### Application

Double fixing

**GO** CODE **493**  
1 with 2 pcs. **kg** 0,3 kg

### Components

- 1 x pin M17x1 - M18x1.5
- 1 x bush M27x0.75

## **G** INJECTOR ADAPTERS SET DENSO, SIEMENS



### Components

- 1 x Denso M25x0.5 - M20x1 injector adaptor
- 1 x Denso M25x0.75 - M20x1 injector adaptor
- 1 x Siemens M25x1 - M14x1 injector adaptor

### Application

Double fixing

**GO** CODE **517**  
1 with 3 pcs. **kg** 0,7 kg

## **G** INJECTOR VALVE SPINDLE SOCKET SIEMENS

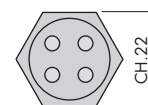

### Technical data

- 4 pins - Ø4 mm
- CH. 22

**GO** CODE **456**  
1 with 1 pcs. **kg** 0,1 kg

**G** INJECTOR VALVE  
SPINDLE SOCKET  
DENSO

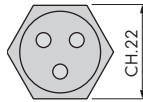

**GO** CODE **457**  
1 with 1 pcs. **kg** 0,1 kg

**Technical data**

- 3 pins - Ø3 mm
- CH. 22

**G** DENSO ADAPTOR

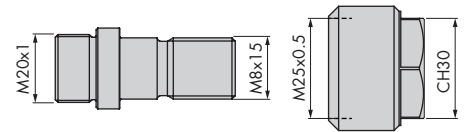

**Application**

Double fixing

**GO** CODE **458**  
1 with 2 pcs. **kg** 0,2 kg

**Components**

- 1 x pin M20x1 - M18x1.5
- 1 x bush M25x0.5

**G** DENSO ADAPTOR

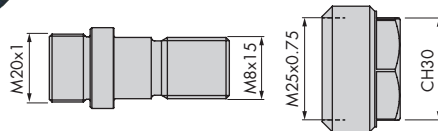

**Application**

Double fixing

**GO** CODE **459**  
1 with 2 pcs. **kg** 0,3 kg

**Components**

- 1 x pin M20x1 - M18x1.5
- 1 x bush M25x0.75

**G** DENSO ADAPTER

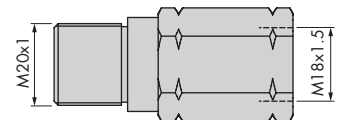

**Technical data**

- connection M20x1
- inner thread M18x1.5
- CH. 24

**GO** CODE **491**  
1 with 1 pcs. **kg** 0,2 kg

## G SIEMENS ADAPTOR

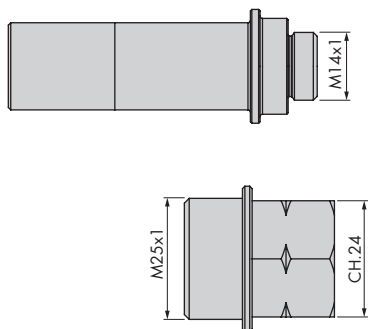

### Application

Double fixing

### Components

- 1 x pin M14x1
- 1 x bush M25x1

<b>GO</b>	CODE	<b>464</b>
<b>1</b>	with 2 pcs.	<b>kg</b> 0,2 kg

## G SIEMENS ADAPTER

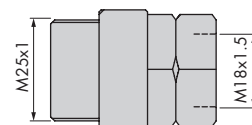

### Technical data

- connection M25x1
- inner thread M18x1.5
- CH. 24

<b>GO</b>	CODE	<b>492</b>
<b>1</b>	with 1 pcs.	<b>kg</b> 0,2 kg

## G SIEMENS ADAPTOR

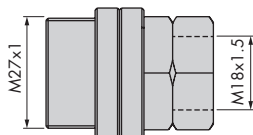

### Technical data

- connection M27x1
- inner thread M18x1.5
- CH. 24

<b>GO</b>	CODE	<b>494</b>
<b>1</b>	with 1 pcs.	<b>kg</b> 0,2 kg

## G DELPHI, BOSCH PIEZO ADAPTOR

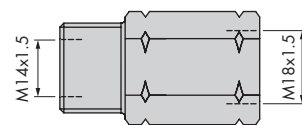

### Technical data

- inner thread M18x1.5
- inner thread M14x1.5
- CH. 24

<b>GO</b>	CODE	<b>479</b>
<b>1</b>	with 1 pcs.	<b>kg</b> 0,2 kg



**G TOYOTA ADAPTOR**

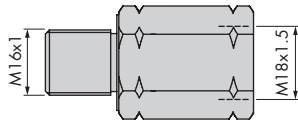

**G INJECTOR SOCKET  
OPEL**

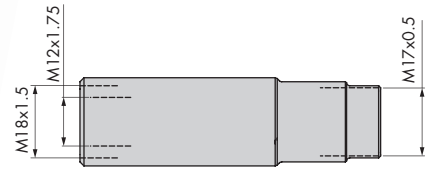

- Socket suitable for removing injectors mounted on GM-Opel 2.0, 2.2 CDTi

**GO** CODE **437**  
 with 1 pcs. **kg** 0,2 kg

- Technical data**
- connection M16x1
  - inner thread M18x1.5
  - CH. 24

**GO** CODE **484**  
 with 1 pcs. **kg** 0,2 kg

- Technical data**
- connection M17x0.75
  - connection M18x1.5
  - connection M12x1.75

**G DIESEL INJECTOR LINE SOCKET WRENCH  
SW12-14-16-17-18-19**



- Set of 6 open-ended polygonal wrenches for mounting and dismounting injector pipe fittings
- Polygonal attachment



**GO** CODE **918**  
 with 6 pcs. **kg** 1 Kg

## INJECTOR REMOVAL SOCKET BOSCH



### Technical data

- Size: CH.29
- Length: 78 mm
- Connection: 1/2"
- Bosch

**GO** CODE **429**  
1 with 1 pcs. **kg** 0,3 kg

## INJECTOR REMOVAL SOCKET BOSCH



### Technical data

- Size: CH.30
- Length: 78 mm
- Connection: 1/2"
- Bosch

**GO** CODE **430**  
1 with 1 pcs. **kg** 0,3 kg

## INJECTOR REMOVAL SOCKET SIEMENS



### Technical data

- Size: CH.25
- Length: 78 mm
- Connection: 1/2"
- Siemens

**GO** CODE **431**  
1 with 1 pcs. **kg** 0,2 kg

## INJECTOR REMOVAL SOCKET SIEMENS



### Technical data

- Size: CH.27
- Length: 78 mm
- Connection: 1/2"
- Siemens

**GO** CODE **432**  
1 with 1 pcs. **kg** 0,3 kg

## INJECTOR REMOVAL SOCKET CR ENGINES

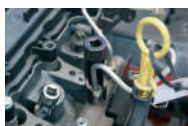

### Technical data

- Size: 17 mm
- Length: 80 mm
- Connection: 3/8"

**GO** CODE **428**  
1 with 1 pcs. **kg** 0,1 kg

## ADAPTER-SOCKET'S FOR INTERNAL VALVE SIEMENS, BOSCH, DENSO



### Components

- 1 x Denso injector valve spindle dismounting tool
- 1 x Siemens injector valve spindle dismounting tool
- 1 x Bosch injector valve spindle dismounting tool



**GO** CODE **516**  
1 with 3 pcs. **kg** 0,3 kg



## INJECTOR SEAT CLEANER SET UNIVERSAL



GO513

### QUICK CONNECTION

1/4" (6.35 mm) hex  
shank connection



- Professional injector seat cleaner set for diesel engines.
- Removes successfully the carbon deposits granting a smooth and even finish.
- A correctly performed cleaning helps to avoid return losses due to a non-optimal assembly of the injectors.

### Components

4 x brass brush Ø18-19-21-24 mm
4 x nylon brush Ø18-19-21-24 mm
1 x flexible extension cable L=230 mm
4 x nozzle sealing cap Ø7 mm
10 x cotton swab L = 250 mm
2 x brass brush c – L=315 mm
3 x abrasive brush
1 x injector sealing cap
2 x brush for sealing seat Ø15-20 mm
1 x 3 mm hex key for mounting cutters
1 x cutter drive tool
1 x cutter for cleaning the injector tip

3 x drill centering cone Ø20.5-17.8 mm,  
Ø22-16.8 mm, Ø24.5-18.8 mm

1 x anti-seize paste 100gr
1 x seal washer extractor Ø7 mm
1 x pivot for impact weight L = 115 mm
1 x slide hammer 1,5 kg
4 x injector sealing seat cleaning cutter <b>A</b>



Type	ØRod (A)	ØBurr (B)	∠
1	18,8 mm	17 mm	30°
2	17 mm	15 mm	0°
3	17 mm	17 mm	0°
4	17,7 mm	17,7 mm	35°-53°

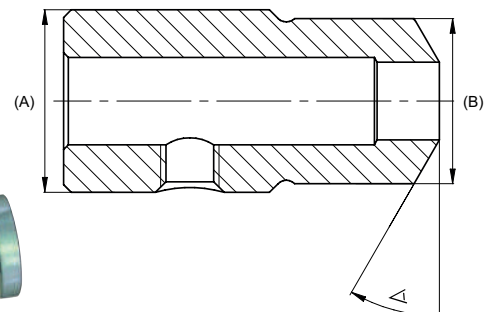

**GO** CODE **538**  
with 30 pcs. **kg** 3,4 kg



**PHASE 1**

Remove the washer

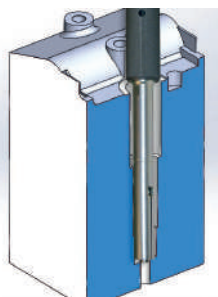

**PHASE 2**

Injector sealing seat  
injector nozzle

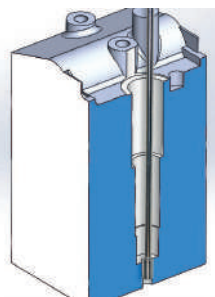

**PHASE 3**

Cleaning / Polishing  
lateral injector seat

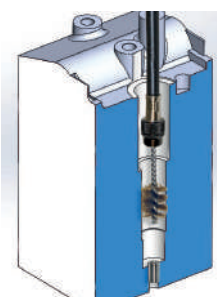

**PHASE 4**

Cleaning of injector seat

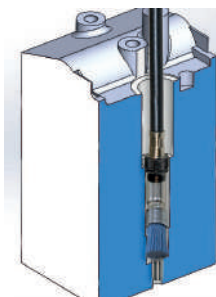

**PHASE 5**

Cleaning of injector  
nozzle seat

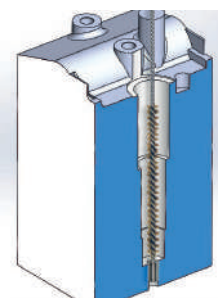

**PHASE 6**

Cleaning burr injector  
seat

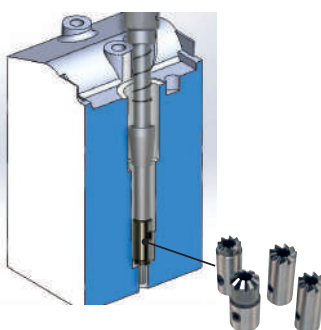

**PHASE 7**

Cotton swab for last  
finishing

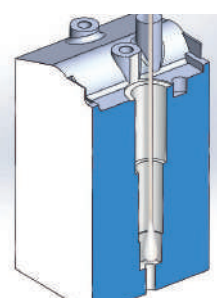

**BRUCHES TECHNICAL DATA**

**FRONT BRUSH NYLON MATERIAL -  
BLUE COLOR**



Professional brush for polishing, grinding, removing rust from metals surfaces, non-ferrous metals, steels and alloys, stainless steel

**+PLUS**

- Nylon thread reinforced with silicon carbide suitable on all metal surfaces, for cleaning and rust removal.
- It leaves no residue on the worked surfaces
- Material: BLUE Nylon thread - Ø1 mm.

Ø15 mm

Ø20 mm

**FRONT BRUSH NYLON MATERIAL -  
WHITE COLOR**



Professional brush for polishing, grinding, removing rust from metals surfaces, non-ferrous metals, steels and alloys, stainless steel

**+PLUS**

- Nylon thread suitable on all metal surfaces, for cleaning and rust removal.
- It leaves no residue on the worked surfaces
- Material: White Nylon thread - Ø0,40 mm.

Ø18 mm

Ø19 mm

Ø21 mm

Ø24 mm

**ROUND BRUSH BRASS MATERIAL**



Professional brush for polishing, grinding, removing rust from metals surfaces, non-ferrous metals, steels and alloys, stainless steel

**+PLUS**

- Brass thread suitable on all metal surfaces, for cleaning and rust removal.
- Material: Brass thread - Ø0,15 mm.

Ø18 mm

Ø19 mm

Ø21 mm

Ø24 mm





## UNIVERSAL CLEANING INJECTOR SEAT SET



- Kit to be used for removing the combustion residues that remain in the injectors seat without any damages.
- For cleaning and maintaining the injector shaft.



**INCLUDED:**

Lubricating grease to be used with threaded bars, nuts etc...

**1** Pipe cleaners for cleaning the headquarters of injector sprayer.

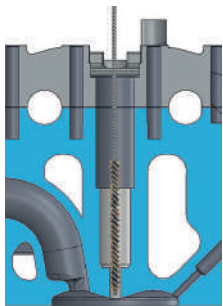

**2** Sealing plugs for the injector housing.

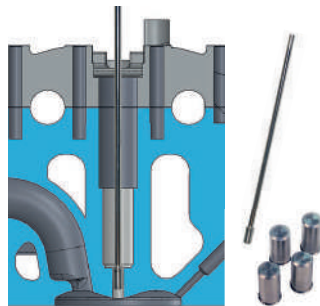

**3** Clening brush for seal seat.

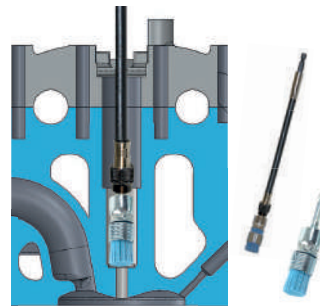

**4** Special cleaning brushes for injector seat.

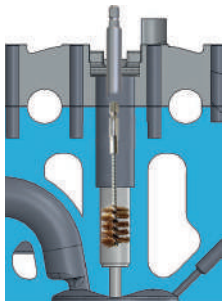

**5** Cutters for cleaning the sealing seat.

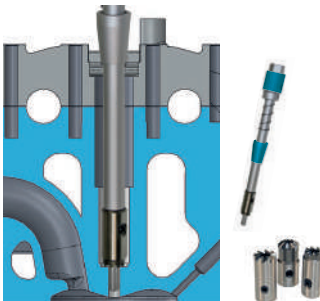

**6** Final finishing with cotton pad.

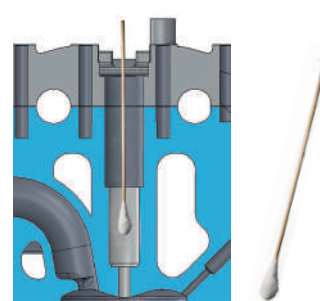

**GO** CODE **415**  
 with 26 pcs. **kg** 4 kg

**G** LOCKING SLEEVES FOR INJECTOR BORE

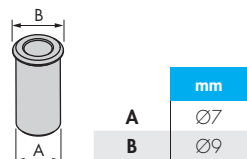

**GO** CODE **445**  
with 6 pcs. 0,1 kg

**G** BRASS BRUSH SET



**Components**  
4 x brush Ø18 - 19 - 21 - 24 mm

**GO** CODE **446**  
with 4 pcs. 0,1 kg

**G** BRASS BRUSH SET



**Components**  
3 x brush 300x100x7

**GO** CODE **447**  
with 3 pcs. 0,1 kg

**G** POLISHING FLEECE BRUSH SET

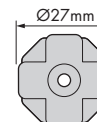

**GO** CODE **448**  
with 3 pcs. 0,1 kg

**G** PNEUMATIC ADAPTOR FOR SWARF REMOVAL DUMMY GLOW PLUG **M8 M9 M10**



- Blowing tool necessary to clean the injector's seat.
- Comes with valve to cut-off air flow through a lever.
- German-type air quick coupling.

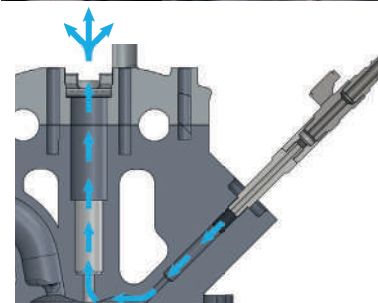

**GO** CODE **510**  
with 5 pcs. 0,3 kg



## **G** DIESEL INJECTOR SEAL EXTRACTOR TRUCK, Ø10 MM

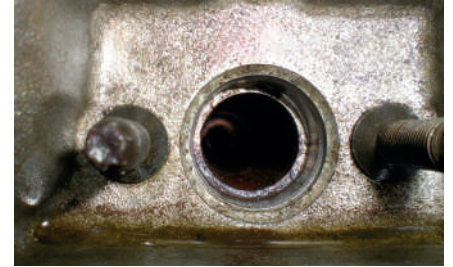

### Technical data

- For washers with holes Ø10 mm.
- Operation with a striking hammer of 0,5 kg.

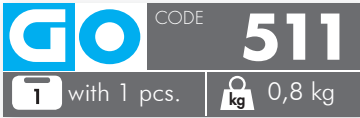

- Tool for the removal of the copper washer (placed on the bottom of the injector seat) post removal of diesel injectors.
- For easily and safely removal of copper washers glued on the bottom of the injector seat.

## **G** DIESEL INJECTOR SEAL EXTRACTOR COMMERCIAL VEHICLE, CARS, Ø7 MM

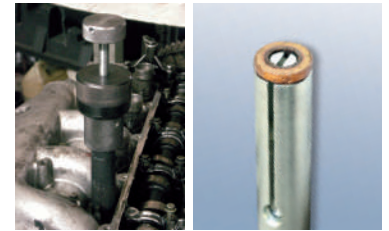

### Technical data

- For washers with holes Ø7 mm.
- Operation with a striking hammer of 0,5 kg.

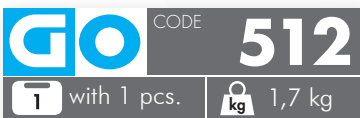

- With this extractor is possible to remove copper sealing without damaging the cylinder head.
- Equipped with a performing slide hammer.

## **G** DIESEL INJECTOR SEAL EXTRACTOR COMMERCIAL VEHICLE, CARS, Ø7 MM



### Technical data

- Operation with a striking hammer of 1,5 kg.

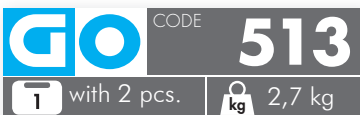

- It includes a slide hammer for removal of diesel injector washers.
- For easily and safely removal of copper washers glued on the bottom of the injector seat.

# G KIT TO RESTORE M6 THREADS ON ALUMINUM ENGINE HEADS UNIVERSAL

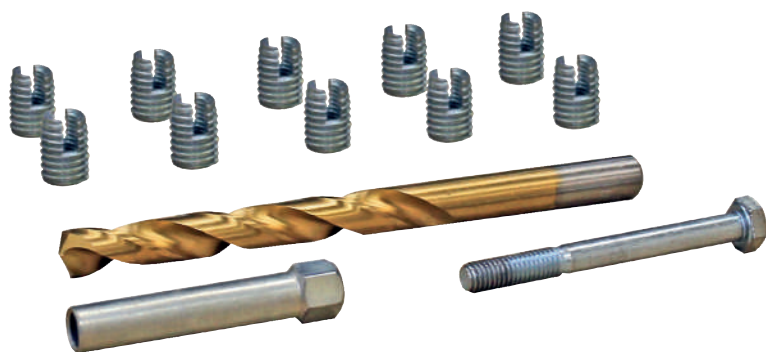

- Special kit to restore the threaded holes on the heads of aluminium heads.
- Can be adapted to restore the threads that support the injectors on diesel engines.

**GO** CODE **1110**  
 1 with 13 pcs. 0,1 kg

**M6**

**Components**

- 10 x thread inserts M6
- 1 x drill Ø9 mm
- 1 x screw
- 1 x centering insert M6

**Application**

MB CDI OM 611, 612, 613, 646, 647, 648 etc.

**Insert installation**



**GO** CODE **1111**  
 1 with 13 pcs. 0,1 kg

**M7**

**Components**

- 10 x thread inserts M7
- 1 x drill Ø9 mm
- 1 x screw
- 1 x centering insert M7

**Application**

MB CDI OM 651, VW, etc.

**Installation**



**GO** CODE **1112**  
 1 with 13 pcs. 0,1 kg

**M8**

**Components**

- 10 x thread inserts M8
- 1 x drill Ø9 mm
- 1 x screw
- 1 x centering insert M8

**Application**

Citroën, Peugeot, Fiat, Iveco 2.3, 3.0 HDI / JTD / HPI etc





## GLOW PLUG PULLER SET M8-M9-M10 UNIVERSAL

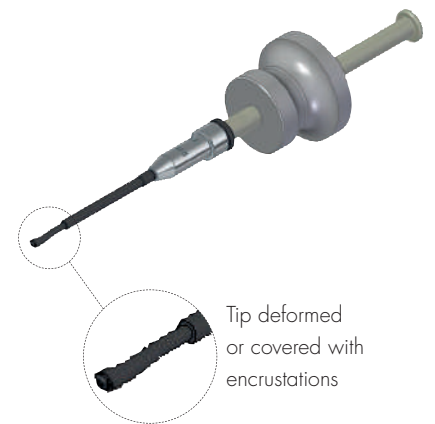

- Since modern glow plugs are increasingly fragile and narrow, a glow plug that has been burnt out for a long time often gets stuck in its seat. Even if you try to unscrew it, it will not come out due to encrustation along its body and also because of deformation which occurred over time in the final part.
- This system quickly and directly grips the hex body of all types of M8-M9-M10 glow plugs.
- Features the innovative fast lock system that ensures maximum quickness.
- Does not damage the cylinder head and guarantees a job done to professional standard.
- Removal through the strokes of the slide hammer provided.

### Components

- 1 x glow plug extractor M8
- 1 x glow plug extractor M9
- 1 x glow plug extractor M10

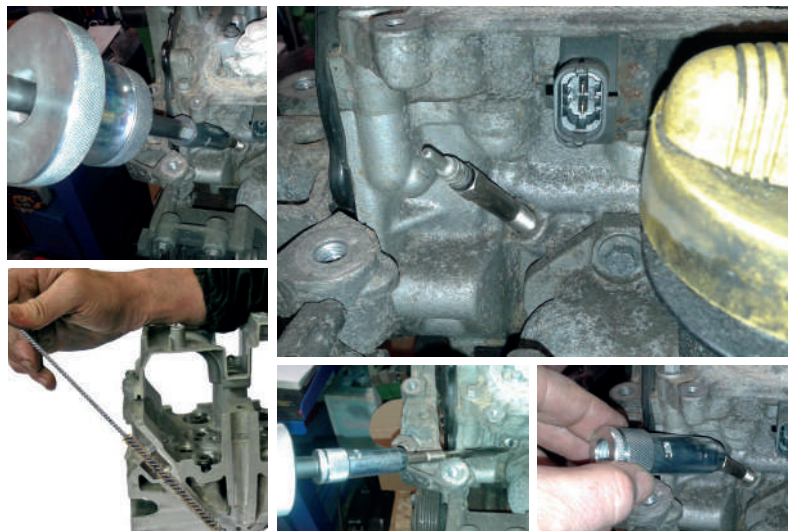

<b>GO</b>	CODE	<b>453</b>
1	with 9 pcs.	kg 2,5
<b>§ PATENTED</b>		

M8 M9 M10



## UNIVERSAL GLOW PLUG TIP EXTRACTION SET M8X1 M9X1 M10X1 M10X1.25



### Solution 1

Pulling out with slide hammer

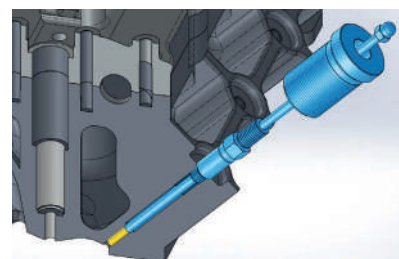

### Solution 2

Pulling out with bearing threaded extractor

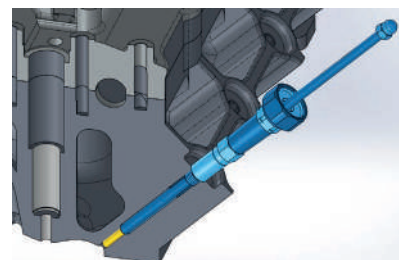

- Set of tools for the extraction of the electrode terminal part of the glow plugs (M8, M9, M10) in the event of breakage or sticking inside the seat part, which is otherwise impossible to remove. The set includes all the tools needed to safely remove the terminal part of the glow plug electrode without damaging the cylinder head. This operation becomes very simple, safe and fast.
- It allows to operate in two different ways:

**1** Extraction with slide hammer

**2** Extraction with threaded extractor



### PLUS:

Developed and reinforced for glow plug with ceramic bulb



**GO** CODE **451**  
 with 20 pcs. 2,5 kg  
 § **PATENTED**

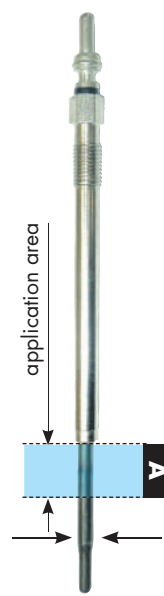

Removing the glow plug tip when the breakage happens inside the AREA **A**

Minimum external diameter electrode tip: Ø4.3  
 Maximum diameter internal pierce: Ø3



## UNIVERSAL GLOW PLUG TIP EXTRACTION SET M8X1 M9X1 M10X1 M10X1.25

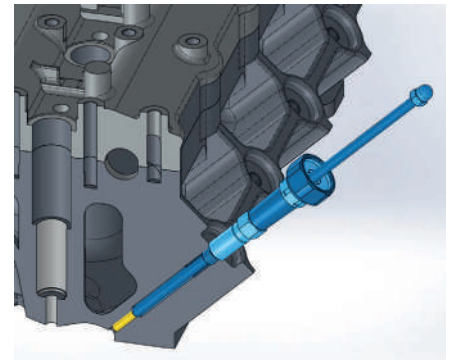

- When extracting glow plugs, the glow plug tip (glow tube) often breaks and remains stuck in the cylinder head. The broken glow plug tips can be easily extracted with the help of this article.
- The set of tools contains all of the tools needed to tap resilient threading into the end of the glow plug. Afterwards the glow plug tip will be extracted with the help of the extraction rod and a striking hammer.
- The drill will be guided precisely using the glow plug threading in the cylinder head. This will avoid any damage to the cylinder head.
- This set can be used with any current diesel motors using threading sizes: M8x1, M9x1, M10x1 and M10x1.25.



**+** **PLUS:**  
APPLICATION RANGE  
INCREASED

Removing the glow plug tip  
when the breakage happens  
inside the AREA **A**

Minimum external diameter  
electrode tip:  $\varnothing 4.3$   
Maximum diameter internal  
pierce:  $\varnothing 3$

### Components

- 1 x core hole drill extension with a diameter of 2.5 for M8x1 and M9x1
- 1 x core hole drill extension with a diameter of 3.2 for M8x1 (special application)
- 1 x core hole drill extension with a diameter of 3.2 for M10x1 and M10x1.25
- 1 x M3 core hole drill extension for M8x1 & M9x1
- 1 x M4 thread tap extension for M8x1 (special application)
- 1 x M4 thread tap extension for M10x1 and M10x1.25
- 1 x M3 extra long extraction rod with cap nut for M8x1 and M9x1
- 1 x M4 extra long extraction rod with cap nut for M8x1 (special application)
- 1 x M4 extra long extraction rod with cap nut for M10x1 and M10x1.25
- 1 x striking hammer, weight 400g
- 1 x tap guide for M8x1 glow plug threads
- 1 x tap guide for M9x1 glow plug threads
- 1 x tap guide for M10x1 glow plug threads
- 1 x tap guide for M10x1.25 glow plug threads

**GO** CODE **452**  
1 with 18 pcs. **kg** 2 kg  
**§ PATENTED**





## ADDITIONAL KIT FOR REPAIRING GLOW PLUGS UNIVERSAL



### Components

1 x 80 mm extension for sliding rod, with key surface
1 x Gr. 1 Step Drill Holder for M8 / M9 (allows greater drilling depth)
1 x Gr. 2 step drill holder for M10 (allows greater drilling depth)
6 x drill bit 3x2.7mm and 3.6mm
1 x 12-28 UNF deep thread tap (with extra thin shaft)
1 x 1/4"-28 UNF deep thread tap (with extra thin shaft)
1 x 12-28 UNF pull-out adapter, extra long 102mm
1 x 1/4"-28 UNF pull-out adapter, extra long 102mm
1 x holder (pull rod) with hexagonal end
1 x electrode drill bit Ø 3.00 mm
2 x cleaning brush for heating rod hole Ø 4.8 + 5.8mm
2 x cleaning brush for glow plug shaft Ø 7.0 + 8.5mm
8 x glow plugs, each 2x M8x1.0 - M9x1.0 - M10x1.0 - M10x1.25

### Application



Necessary to create a new thread deep inside the glow plug.

They are especially needed for long glow plugs, which have already been broken/stripped during removal.

These brushes let you clean the glow plug seat in the cylinder head after the glow plug is removed.

The threaded plugs are used to close the glow plug hole on the cylinder head.

- Useful addition to existing Govoni glow plug tip sets and to all complete ranges specific for diesel engines and vehicles.
- Particularly interesting when the glow plug breaks several times during the extraction phase with the standard removal tools and a new grip thread must be created deep inside the glow plug.
- Threaded plugs are used to temporarily close the inlet hole of the glow plug in the cylinder head.
- The engine can be started with the result that the glow plug residue in the duct, the heat produced by the engine is expelled. Subsequently, the residue (dust, soot etc ...) can be removed without problems with the tools contained in the kit.

**GO** CODE **539**  
with 27 pcs. **kg** 3,2 Kg



**+** **PLUS**  
Supplied with brushes for cleaning the heating tube and glow plug shaft.





## UNIVERSAL GLOW PLUG TIP EXTRACTION SET: BREAKAGE ROD + TIP SOLUTION M8 M9 M10 UNIVERSAL

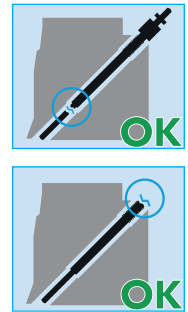

### Glow plugs extraction kit

- Set designed for M8x1, M9x1, M10x1 and M10x1.25 glow plugs when they break in close proximity of the hex, making impossible the extraction. The extraction occurs through the usage of a 1,5 kg slide hammer

### Electrode tip extraction kit

- Set designed for M8x1, M9x1, M10x1 and M10x1.25 glow plugs when they break deeply inside the glow plug housing. Extraction occurs mechanically.

SOLUTION ROD  
BREAKAGE

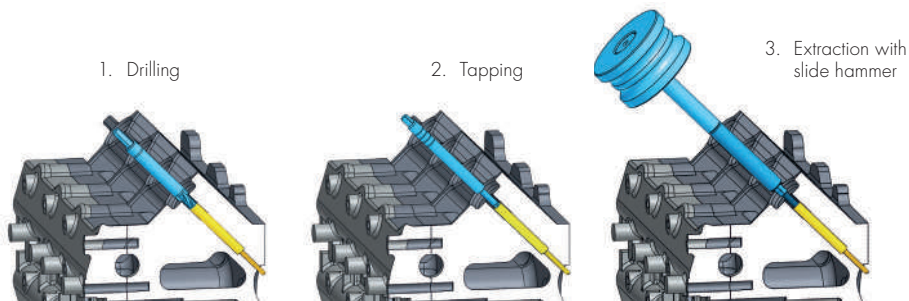

SOLUTION ELECTRODE  
TIP BREAKAGE

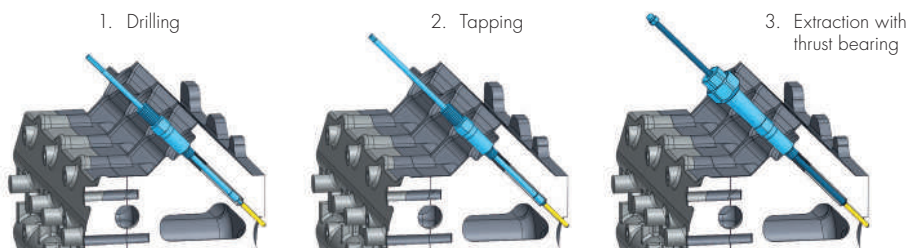

<b>GO</b>	CODE	<b>540</b>
<b>1</b>	with 41 pcs.	<b>kg</b> 5,3 kg
<b>§ PATENTED</b>		



## UNIVERSAL GLOW PLUG REMOVAL SET - MASTER M8X1-M9X1-M10X1-M10X1.25

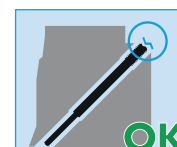

- The pre-heating glow plug used in diesel engines can often get stuck inside the engine head due to residues caused by the combustion process. In these cases, the glow plug will break when you try to remove it; consequently, you will have to disassemble the head in order to remove it. This job need in long intervention time and high costs.
- Govoni specializes in the extraction of broken or stuck glow plugs and allows you to carry out rapid and efficient extraction steps by using its highly professional equipment.
- The equipment allows you to: reduce intervention time and costs, extract and restore the thread in order to mount the new glow plug to a professional standard.
- The complete tool kit consists of 4 modules: **n.3 modules** are specific for one special glow plug size, and **n.1 module** is a basic tool kit and is essential for using the 3 specific modules for each glow plug size.

### Application

<b>M8x1</b>	Mercedes, Smart, VW, Fiat, Opel, Ford etc.
<b>M9x1</b>	Opel, Fiat, Alfa, Lancia (es. 1.3-2.3-3.0 JTD) etc.
<b>M10x1</b>	VW, Audi, Mercedes, BMW, Opel, PSA, Renault, Ford, Suzuki etc.
<b>M10x1.25</b>	VW, Audi, Toyota, Suzuki, Opel, Isuzu, Mercedes etc.



**GO** CODE **470**  
**1** with 29 pcs. **kg** 5,3 kg

**G** BASIC SET, FOR COMMON WORK



**Use of the components**

- 1 x controlled breakage and drilling out of the middle electrode (sockets Ø2,5; Ø3,5; Ø4 / 2 x milling cutters Ø2,7; Ø3,6)

---

- 1 x pull rod with slide hammer (1,5 kg) for knocking out the glow plug

---

- 1 x bar magnet for picking up fragments, chips, small parts



**GO** CODE **471**  
 1 with 12 pcs. **kg** 5,2 kg

**G** MODULE **M8** - GLOW PLUG REMOVAL



**Components**

- 1 x special long milling cutter (Ø4.5) and steel milling cutter (Ø7-4.5 mm) with 4 TiN-coated and self-centering cutting edges

---

- 1 x thread insert 12-28 UNF

---

- 1 x threaded male to create the thread to remove the glow plug 12-28 UNF

---

- 1 x threaded male to restore the M8x1 glow plugs thread



**GO** CODE **472**  
 1 with 5 pcs. **kg** 0,5 kg

**G** MODULE **M9** - GLOW PLUG REMOVAL



**Components**

- 1 x special long milling cutter (Ø4.5) and 1 x steel milling cutter (Ø8-4.5 mm) with 4 TiN-coated and self-centering cutting edges

---

- 1 x thread insert 12-28 UNF

---

- 1 x threaded male to create the thread to remove the glow plug 12-28 UNF

---

- 1 x threaded male to restore the M9x1 glow plugs thread



**GO** CODE **473**  
 1 with 5 pcs. **kg** 0,5 kg

**G** MODULE **M10** - GLOW PLUG REMOVAL



**Components**

- 1 x special long milling cutter (Ø5.5) and 2 x steel milling cutters (Ø8.9-5.5 mm) with 4 TiN-coated and self-centering cutting edges

---

- 1 x thread insert 12-28 UNF

---

- 1 x threaded male to create the thread to remove the glow plug 12-28 UNF

---

- 2 x threaded male to restore the glow plugs thread (M10x1; M10x1.25)

Dimension A ≥ 14 mm + ≥ 20 mm



**GO** CODE **474**  
 1 with 7 pcs. **kg** 0,6 kg



## G GLOW PLUG REMOVAL KIT M8x1 - M9x1, FOR FCA GROUP, OPEL, FORD, SUZUKI -1.3 MJ ENGINES

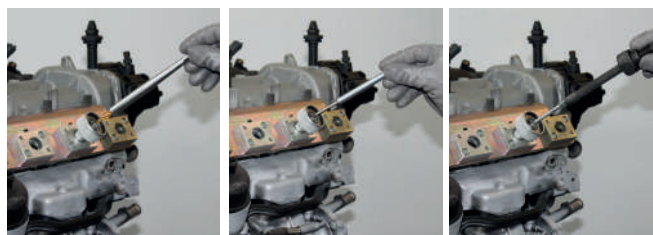

**PLUS:**

New application for M9 glow plugs

**Components**

- 1 x special gauge
- 2 x drill with centering
- 1 x male M8X1
- 1 x male M5
- 2 x thread insert
- 2 x special drill
- 1 x male M9X1
- 1 x centering tool with a screw and nut

Brand	Engine
ALFA ROMEO	1.3 JTD
FIAT	1.3 Multijet
LANCIA	1.3 MJTD
FORD	M9x1
OPEL	1.3 CDTI
SUZUKI	1.3 DDIS



- Professional kit employed to extract stuck glow plugs, specifically for FCA group 1.3 Multijet.

**GO** CODE **489**  
with 16 pcs. 4 kg

## G UPGRADE SET FOR GLOW PLUG EXTRACTION M9X1, FCA 1.3 MJ



- Professional tools needed to extract M9x1 glow plugs, in use on the latest FCA 1.3 Multijet engines (from Euro 4 onwards).
- The set is **NOT USABLE ON ITS OWN**, it is required as a supplementary kit for **GO489** and earlier versions.

**GO** CODE **499**  
with 4 pcs. 0,1 kg



## G BOSCH DUMMY INJECTOR



- For injecting compressed air during cleaning and repair work on the glow plug shaft or for keeping valves in an upward position when working on the valve stem seals.

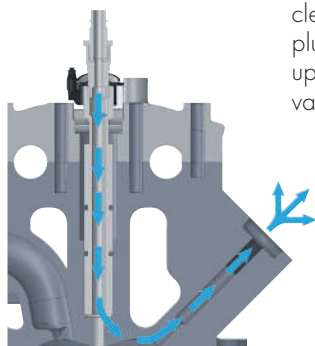

**GO** CODE **509**  
with 1 pcs. 0,4 kg





## SET OF TOOLS FOR REPLACING ELASTIC V-BELTS UNIVERSAL

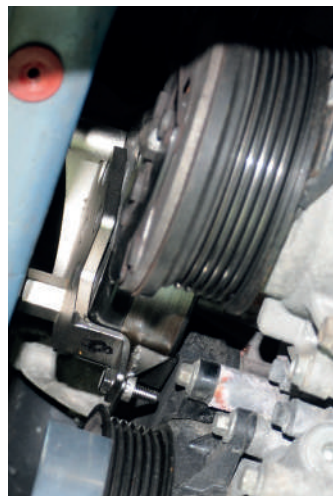

- Assortment of tools for the assembly and disassembly of Flex belts.
- The "Flex" belts drive the auxiliary units in the engine such as the generator, the fan, the water pump, the air conditioning compressor, the power steering etc. Brands and names of compatible/similar products such as, for example, Gates (Strecht Fit™), ContiTech (Conti-V Multirib Elast-Belt), Optibelt (EBK belts).
- The very wide range guarantees very high market coverage of approximately 95%.
- No damage to belts and pulley.
- Suitable for single- and double-acting pulleys.

### Application

Universal use on vehicles/SUVs and Vans.

Brand: BMW, Audi, Seat, Skoda, VW, Chrysler, Ford, Mazda, Mercedes, Peugeot, Citroen, Fiat, Iveco, Volvo, Fiat, Lancia etc.

### Components

- 1 x tool for belt assembly short type 1 for double-acting pulleys
- 1 x tool for assembly of belt Ø50, Type 2 groove width 3.1 mm
- 1 x tool for assembly of belt Ø50, Type 3 groove width 10.4 mm
- 1 x spacing bolts set, 2 pcs. for mounting tool type 1, 2, 3
- 1 x tool for assembly of belt Ø32, Type 4
- 1 x spacing bolts set, 3 pcs. for mounting tool type 4
- 1 x tool for disassembly of belt

- 1 x belt positioner with shim for water pump, Ford/Volvo
- 1 x double-acting pulley adapters, Ford/Volvo
- 1 x two-sided ½ engine rotation tool, BMW
- 1 x spacing tool, aluminium, 1.8+2.2 D Van
- 1 x belt assembly tool, plastic 1.8+2.2D Van

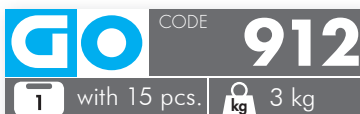

## G STRETCH BELT FITTING TOOL - DUAL SIZE PULLEY

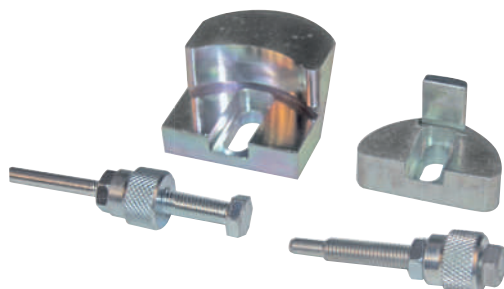

- Specially designed two-piece tool for installing and dismantling stretch belts on double pulleys.
- Easy and fast belt replacement.
- Any damage to pulleys and belts granted.

### Application

Universal application for all pulleys  
Alfa Romeo: 159 2.4, MJ  
Fiat: Multipla, Bravo, Croma 1,6 petrol engine and 2,4 MJ  
Lancia: Lybra 1,6 petrol engine  
BMW: Serie 1, Serie 3  
Citroën: C Picasso, C4, C4 Picasso, C5, Jumpy, Berlingo 1.6 HDI  
Peugeot: 207, 308, 407, Partner,

5008, 3008 1.6 HDI  
Ford: Focus, C-Max 1.6 TDCI  
Mazda: 3 1.6 DE



**GO** CODE **920**  
with 8 pcs. **kg** 0,6 kg

## G STRETCH BELT FITTING TOOL

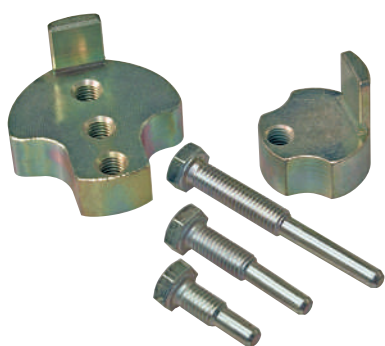

- Special kit suitable for mounting the new stretch belts.

### Components

1 x belt fitting tool Ø50  
1 x belt fitting tool Ø32  
1 x screw M8x25 Ø5,9 mm  
1 x screw M8x40 Ø5,7 mm  
1 x screw M8x65 Ø5,6 mm



**GO** CODE **915**  
with 5 pcs. **kg** 0,4 kg

## G STRETCH BELT FITTING TOOL UNIVERSAL

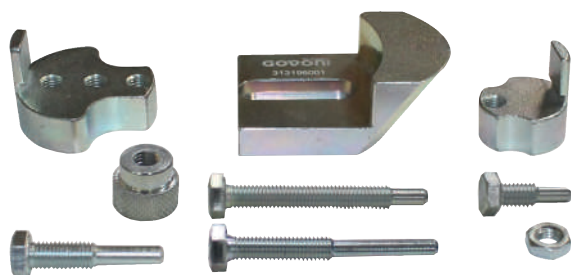

- Removal/assembly of Poly-V elastic belts for single and double pulleys.
- In order to apply to double pulleys you must check how much space is available, for the use of the equipment.
- Assembly and adjustment with centring device.

### Disassembly



### Assembly



**GO** CODE **910**  
with 8 pcs. **kg** 2,5 kg



## TIMING BELT CHECKING GAUGE PSA/OPEL, 1.0/1.2

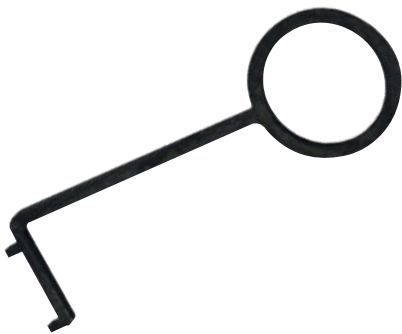

- This tool is used to assess toothed belt wear.
- **Special feature:**

The toothed belts of these motors operate in an oil bath. Due to the ageing process or lack of additives in the oil, the toothed belt structure may change or wear out.

The gauge is used to determine if the toothed belt width is within the maximum allowed size. If the belt deviates from the manufacturer's specifications, it must be replaced.

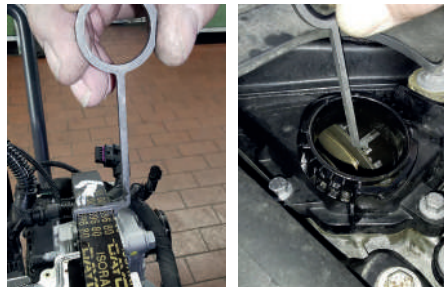

### Application

Citroen 1,0/1,2 L/Peugeot 1,0/1,2 L/  
Opel/Toyota 1,2 L

### To be used as OEM

- PSA - 1643190080/G-0109-6
- Opel - EN-52809

**GO** CODE **945**

with 1 pcs. 0,1 kg



## AUXILIARY BELT TENSIONER TOOL SET PSA



- Kit for tensioning the elastic and flat belts of the auxiliary parts of the PSA group vehicles.
- The special rectangular adapters ensure a perfect grip on the vehicle parts, and can be coupled to the most common wrenches on the market, making practical and quick the assembly and disassembly process of the belts on the auxiliary parts pulley.

Components	OEM CODE	ref.
1 x Basic connection adapter	OE 01099-A	1
1 x 8.7 mm automatic tensioner adapter	OE 01099-B1	2
1 x 10 mm automatic tensioner adapter	OE 01099-B2	3
1 x SW15 double hex adapter	OE-01099-C	4
1 x SW15 Hex adapter x square 1/2"	OE-01099-D	5

Application		
<b>CITROËN</b>		
<b>FORD</b>		
<b>MAZDA</b>	1.4; DV4TD; DW10FD; T3JA; W16D16; DV4TED4;	OE PZ410-G0109-90
<b>MINI</b>	1.5; UBGA; TZJA; 9HZ; DV6TED4; XJJB; AEDA; D4164T;	
<b>PEUGEOT</b>	1.6; DV6ATED4; HHJC; G8DC; 2WZ-TV	
<b>TOYOTA</b>	2.0;	
<b>VOLVO</b>	2.2L	
	Also suitable for DW10 and DW12 engines	

**GO** CODE **924**

with 5 pcs. 0,3 kg





## PULLEY COUNTERHOLDER FOR BMW



- Crankshaft pulley holding tool on BMW engines.
- Holds the vibration damper when loosening or tightening the centre crankshaft bolt.

Application			
BMW	E81 120D	163 CV	OEM 11 6 310 (holder 11 6 311 - centering tube 11 6 312)
	E46 318D	115 - 116 CV	
	318TD	115 CV	
	E46 320D	136 - 150 CV	
	E90 318D	150 CV	
	320D	150 - 163 CV	
	E91 318D	122 CV	
	320D	150 - 163 CV	
	E39 520D	136 CV	
	E60 520D	150 - 163 CV	
	E61 520D	150 - 163 CV	
E83 X3	2.0D 150 CV		

**Suitable for crankshaft pulleys with BMW part numbers**

### Technical data

- **M10:** 40Nm+120°
- **M18:** 100Nm + 150°.
- centering tube Ø ext. 60mm, Ø int. 49mm.

11 23 7 787 304  
11 23 7 790 921  
11 23 7 793 882  
11 23 7 801 977  
11 23 7 805 696

**GO** CODE **697**  
1 with 1 pcs. 1,8 kg



## CRANKSHAFT PULLEY HOLDING TOOL UNIVERSAL

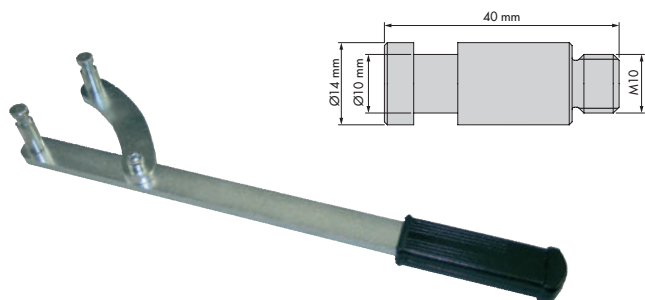

- Wrench suitable for locking crankshaft and camshaft pulleys during the belt replacement.



**GO** CODE **824**  
1 with 1 pcs. 1 kg



## PULLER FOR INJECTION PUMP PULLEY BMW



### Application

M47 (only the puller)  
M47TU (puller and centering bush)  
M57 (puller and centering bush)  
M57TU (puller and centering bush)

### Components

1 x centering bush  
1 x M40x1.5 mm  
1 x M42x1.5 mm

**GO** CODE **825**  
1 with 3 pcs. 0,6 kg





## HARMONIC DAMPER UNIVERSAL PULLEY PULLER SET

**NEW**

- With the help of this special extractor, almost all spoked harmonic balancers on European, Asian, and American vehicles can be removed.
- The set of components allows working with a variety of pulleys of different sizes and brands.
- The compact design also allows working in various installation positions and in tight spaces.



<b>GO</b>	CODE	<b>832</b>
<b>T</b>	with 15 pcs.	<b>Kg</b> 0,50 Kg
<b>§</b>	<b>PATENTED</b>	

## G CRANKSHAFT PULLEY PULLER FORD TRANSIT 2.0 TDCI FROM 2016

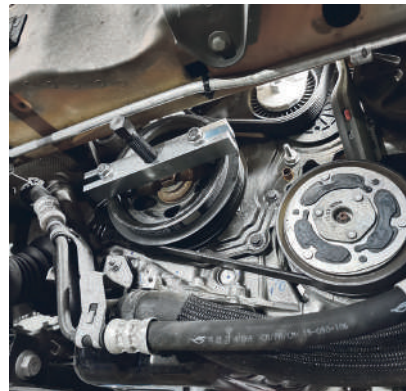
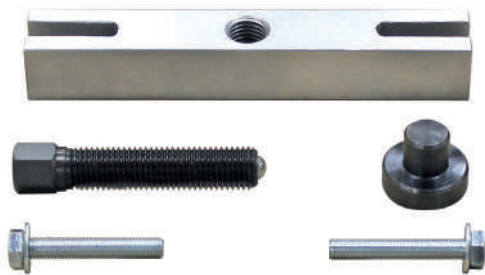

- The kit allows you to remove the anti-vibration pulley on Ford 2.0 Eco Blue engines without damaging the rubber components.
- The peculiarity of this engine is that the toothed belt runs in the area of the engine in oil bath.

### Application

FORD	Focus	2018	2.0EcoBlue TDCI	BCCC, YLCB, YLDA, YLF6, YLFA, YLFB, YLFS, YLB6, YLBA, YMCB, YMF6, YMFA, YMFB, YMFS, YMHA, YMR6, YMRA, YNCA, YNF6, YNFA, YNFB, YNFS, YNR6, YNRA
	Galaxy	2018		
	S-MAX	2018		
	Tourneo Custom	2016		
	Transit	2016		
	Transit Custom	2016		

**GO** CODE **827**  
1 with 7 pcs. 1 kg

## G FORD ENGINE BRACKET SCREW SOCKET



- To remove/install the front engine mount in a 2.0L EcoBlue diesel - 1/2" drive. By using the special tool, you ensure that the screw can be loosened and tightened professionally.

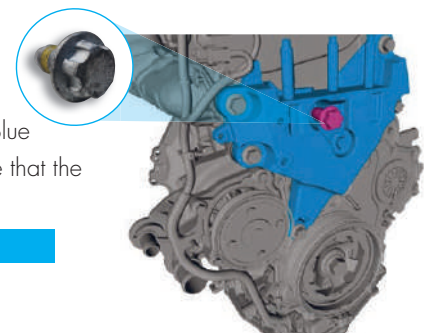

### Application

FORD	Transit Custom	2012	2.0L EcoBlue	303-1694
	Mondeo	2014		
	Galaxy	2015		
	S-Max	2015		
	Edge	2016		
	Focus	2019		
	Kuga	2019		

**GO** CODE **687**  
1 with 1 pcs. 0,16 kg

## G PULLER FOR INJECTION PUMP BMW



### Application

N47, N57  
OEM code: 11 8 030; 11 8 740

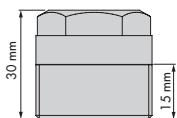

**GO** CODE **858**  
1 with 1 pcs. 0,1 kg

## G HIGH PRESSURE PUMP EXTRACTOR HYUNDAI, KIA

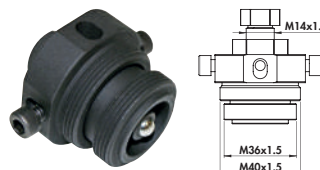

- The tool is used to remove the high pressure pump.
- **TO BE USED AS OEM 09331-1M100.**

**Application**  
Hyundai and Kia CRDi  
- diesel engines chain  
2.0 and 2.2L

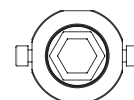

**GO** CODE **811**  
1 with 1 pcs. 0,4 kg



## TOOL FOR ABSORBED PUMP RING NUT FCA



- Tool for disassembling / tightening the absorbed pump fixing ring nut.

### Application

Brand	Model	Engine
FIAT	500L - 500X - Panda (dal 2012) - Freemont - Tipo (from 2015)	0.9 TwinAir, 1.3 MJ, 1.4 Fire/T-Jet, 1.4 MultiAir/TurboJet, 1.6 MJ, 1.6 E-torq, 2.0 MJ, 2.4, 3.6 V6
	JEEP Renegade	1.6 E-torq, 1.6 MJ, 2.0 MJ
LANCIA	Ypsilon	0.9 TwinAir, 1.3 MJ
ALFA ROMEO	Mito - Brera - Giulietta - 159 - Giulia - Stelvio - Spider	0.9 TwinAir Turbo, 1.3 JTDM, 1.4 Turbo MultiAir/TJet, 1.6 JTDM, 2.0 JTDM, 2.0, 2.2 D, 2.4 JTDM



OEM  
2.000.002.100



CODE **619**

1 with 1 pcs. 0,3 kg



## OIL FILTER REMOVER SET FOR FCA GROUP, OPEL, SUZUKI, 1.3 MJ



- This 3-legs special tool and the support allow to assemble and disassemble the plastic lock nut of the new filters on Fiat Multijet.

### Application

FIAT	Punto	1.3 Multijet 16v
	Panda	
	Idea	
	Stylo	
	Doblo	
LANCIA	Ypsilon	1.3 Multijet 16v
	Musa	
OPEL	Corsa	1.3 CDTI
	Agila	
SUZUKI	Ignis	1.3 DDiS 16v
	Vagon R+	



CODE **641**

1 with 1 pcs. 1 kg





## CARBURETOR FLOAT REMOVER KIT PSA, RENAULT



### ADAPTERS

Set	Drawing	h (mm)	L (mm)	a (mm)	b (mm)
1	A	30	108	-	-
2	A	65	108	-	-
3	B	52	92	5	12
4	B	65	92	4	12
5	C	40	92	2	10

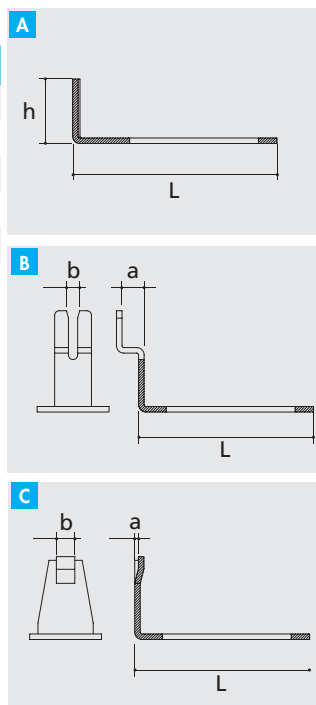

- Carburetor float remover equipped with 5 series of extensions, that include also PSA Group and Renault models.
- It covers different diameters: from min. 70 to max. 170 mm.

**GO** CODE **645**  
 with 16 pcs. 1,9 kg



## GERRIDAE QUICK CONNECTOR RELEASE TOOL



The gripping fingers are placed on the buttons and pressed with the hand.



### Application

for example ARaymond-Fuel couplings  
Universally applicable for fuel quick-couplings on cars, vans, trucks, etc.

- Special tool to release/open quick-couplings with double-click lock (2 buttons). The product is equipped with two tool heads (fingers) of different sizes, which can be used according to the access opening. Moreover, there is a joint on the long end of the tool for better access.
- The fingers are simply placed on the clutch buttons and pressed together with a hand.

### Technical data

- Total length 198 mm
- Height 5 mm

**GO** CODE **076**  
 with 1 pcs. 0,1 Kg





## QUICK-FIT PLIER UNIVERSAL



- The flexible quick-fit pliers are designed to open quick connectors.



### Technical data

- Material: steel hardened
- Weight: 500 g
- Length: L = 250 mm
- Cable Length: L = 590 mm
- Caliper head: L = 80 mm
- Plier opening: 27 mm +/- 2

**GO**

CODE

**805**

**T** with 1 pcs.

**kg** 0,5 kg



## HOSE CLAMPS PLIER (MUBEA AND NORMA) UNIVERSAL

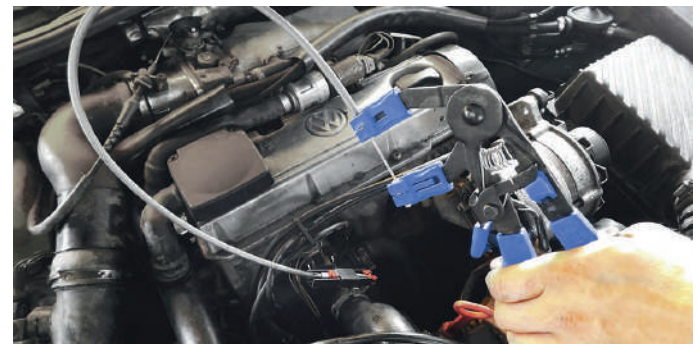

- This flexible quick-fit plier with reinforced sleeve is used to open and close self-arresting lock hose clamps.

Hose clamp type	Ø	Width
MUBEA	Ø18-54 mm	12+15 mm
NORMA		

### Technical data

- Plier length: 260 mm
- Sleeve length: 730 mm



**GO**

CODE

**809**

**T** with 1 pcs.

**kg** 0,4 kg

**G** **PLIERS FOR REMOVING FUEL LINES WITH QUICK COUPLERS UNIVERSAL**



- These special pliers let you open quick connectors (double click).
- The pliers have a swivelling and adjustable head that can also be adapted to quick couplings for VAG fuel with very small connectors and positioned in inaccessible areas.

**ARAYMOND QUICK CONNECTOR**

Angled



Straight



Quick couplings for VAG fuel



**Application**

Universal for fuel and AdBlue connectors, for example on Audi, BMW, Chrysler, Fiat, Mercedes, Opel, Peugeot, Renault, Seat, Skoda, VW etc.



**G** **CONNECTOR REMOVAL TOOL VW GROUP**

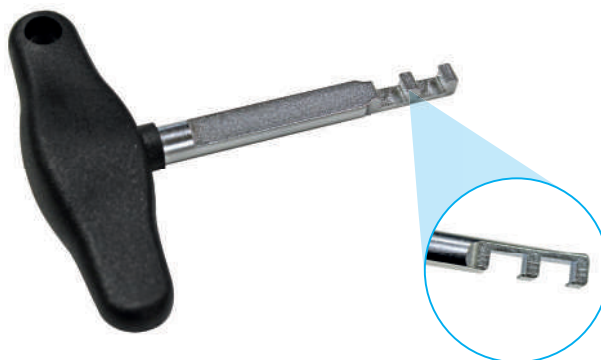

- These tools are designed specifically for removing connectors and releasing terminals of the VW Group vehicles (Audi, Seat, Skoda, Volkswagen) and Porsche connectors.
- For safe and proper removing of most VAG push & pull connectors e.g. electrical connector on mass air flow sensor (MAF), pressure sensor (MAP), ignition coil pack, headlight, fog light, level sensor, etc.

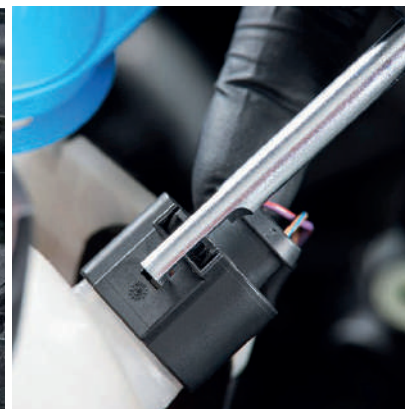

**GO** CODE **828**  
 1 with 1 pcs. **kg** 0,35 kg



**Technical data**

- Total length 270mm
- Length of the swivel head 50 mm
- Finger pliers Ø 4.5 mm / conical

**GO** CODE **693**  
 1 with 1 pcs. **kg** 0,7 kg



## RELEASE PLIERS FOR ELECTRICAL CONNECTIONS SHORT GRIPPERS, UNIVERSAL



- These special pliers unlock the locking tabs on the electrical connectors, component connectors and wiring connectors.
- The simple and safe way to remove small, thin or recessed connectors that are difficult to access.

- **Other advantages:**

Special blade grip profile for tight working space

Optimal access thanks to particularly angled grip arms

Automatic opening pliers - ensures good handling

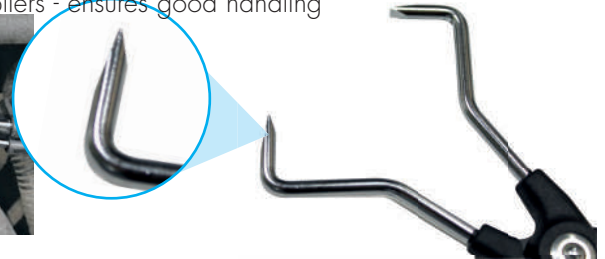

**Technical data**

- Overall length: 175 mm.
- Grip arm length 60 mm
- Opening width max. 45 mm



## RELEASE PLIERS FOR ELECTRICAL CONNECTIONS LONG GRIPPERS, UNIVERSAL



- These special pliers unlock the locking tabs on the electrical connectors, component connectors and wiring connectors.
- The simple and safe way to remove small, thin or recessed connectors that are difficult to access

- **Other advantages:**

Extra Long Grip Arms - Ideal for extended shape connectors

Corrugated grip profile - secure grip even on slippery connector housing surfaces

Automatic opening pliers - ensures good handling

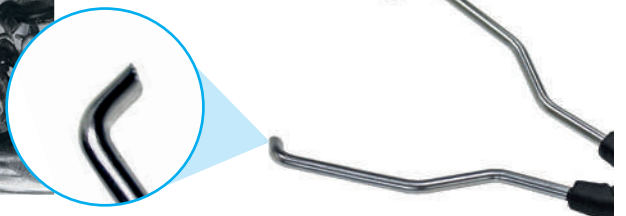
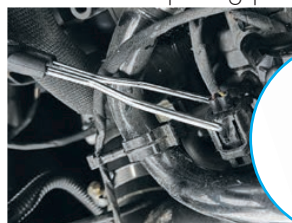

**Technical data**

- Overall length 205 mm
- Grip arm length 90 mm
- Opening width max. 65 mm

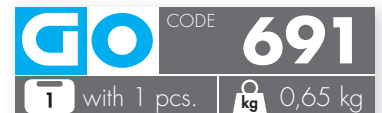





## SELF ADJUSTING CLUTCH (SAC) INSTALLER MASTER KIT



### Application

With the 4-arms plate (code 318004002) it is possible to work on all SAC clutches with multiple of 4 holes (e.g.: Mercedes A-Class (up to 2004 W169).

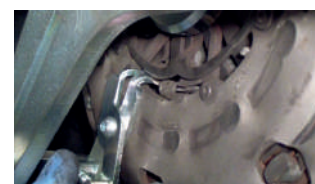
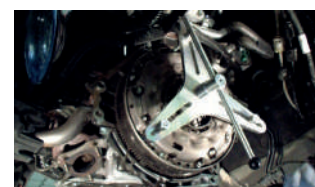

- Using a specialized tool is an absolute must for ensuring the proper installation of the self-adjusting clutch.
- It avoids erratic adjustment of the adjusting ring in the clutch's mechanisms and thereby ensures smooth operation of the clutch after installation.
- Depending on the flywheel's hole pitch grouping (six or eight screws), the pressure plate must be setup to work with the truss with the correct number of arms.
- Use the 3-arm truss for flywheels with six mounting screws and the 4-arm truss for flywheels with eight mounting screws.
- Delivery will include the 14 piece special centering tool set for vehicles without pilot bearings in the crankshaft.  
Problem: in these vehicles, the inside diameter of the crankshaft hole is greater than the disc hub clutch hole.

### Components

1 x standard centering tool with guide and clamp components  
2 x plastic clamping sleeves for the clutch disk hub, Ø15-28 mm  
7 x centering pins for the pilot bearings Ø12-14-15-16-17-18-19 mm  
1 x specialized centering tool set for BMW, 6 pieces including handle (Ø15/23 – Ø15/26,5 – Ø15/28 – Ø15/34 + specialized centering sleeves)

1 x specialized centering tool set with 2 clamping components, 14 pieces  
1 x 3-piece pressure plate with centering expander and handle  
2 x trusses for groups of 3 holes and 4 holes  
12 x mounting bolts, 4 each M6, M7 and M8  
4 x lock nuts for the mounting bolts  
1 x extractor tool

### Centering expander

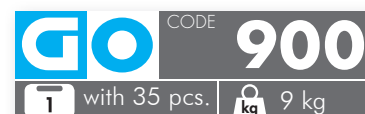
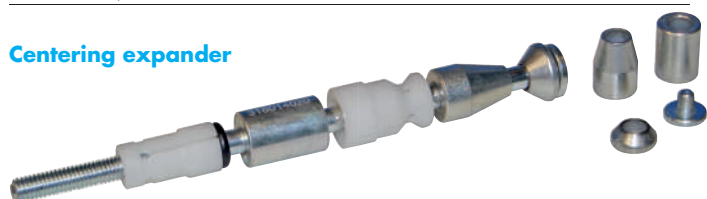





## SELF ADJUSTING CLUTCH (SAC) INSTALLER KIT



- This kit allows the easy dismounting, removal and replacement of all self-adjusting clutches SAC (SAC = Self-Adjusting-Clutch).
- The kit includes a centring tool specific for SAC models with the diameter of the crankshaft bore (driving bearing seat) bigger than the diameter of the clutch hub and without the driving bearing.
- It is equipped with 2 plates: 3-arms and 4-arms (specific for MB), for clutches with 6 or 8 locking holes.
- During assembling and disassembling operations the pre-tightening of the pressure plate is required in order to avoid clutch deformations.
- Clutch disk centring accordingly to the driving bearing or to the pressure plate.
- Adjusting ring resetting using the pre-tightening tool together with the adjusting tool.

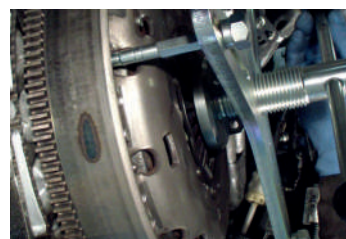
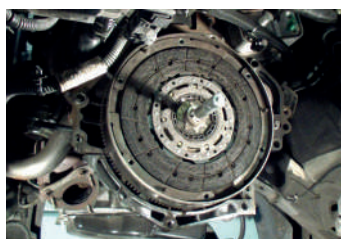

### Advantages

- Longer life clutch
- Reduction of vibrations
- Faster working time
- For engines with manual-shift gear box

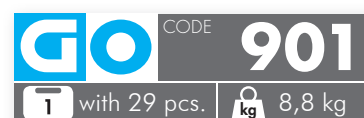

**+ UPGRADE CLUTCH ALIGNER TOOL SET**

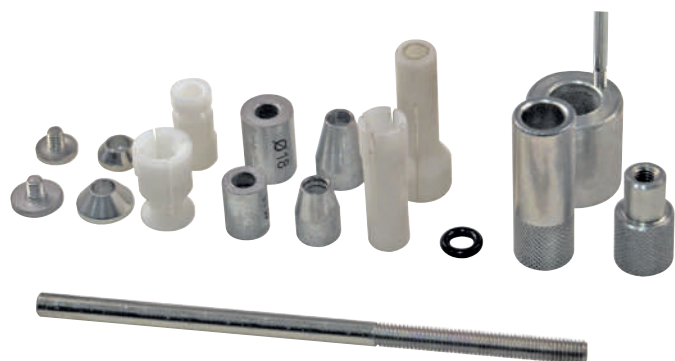

- The clutch aligner tool set can be used on all the brand and models of vehicles.
- Guarantee to operate and to fit perfectly in all cases of different hole crankshaft variation:
- Problem **1**: Centering a Standard-Clutch using pilot bearing centering pin and expander;
- Problem **2**: when the clutch pilot bearing is inside the crankshaft hole, its diameter is smaller than the inner diameter of the clutch disk;
- Problem **3**: When the clutch pilot bearing is not inside the crankshaft hole, the diameter of the hole is larger than the diameter of the clutch disk.

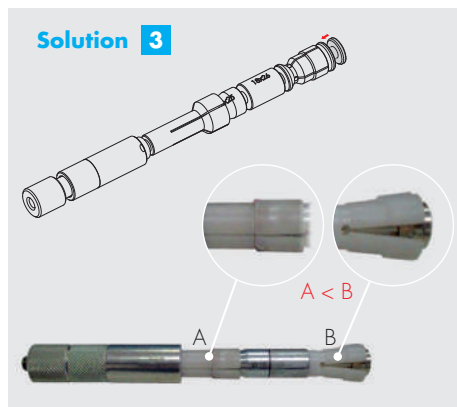
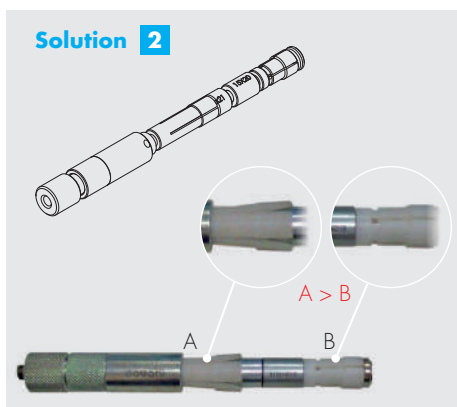
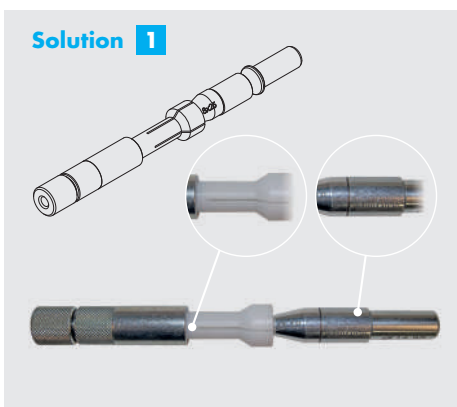

A	B	C
min. Ø15 mm max Ø27 mm	Ø15-21 mm Ø20-25 mm	Ø12 mm Ø14 mm Ø15 mm

**Usage specification**

Centering of clutch pilot bearing (inner Ø12, 14, 15 mm) by using the corresponding fixed centering pins  
Blocking/centering for crankshaft hole (Ø12 mm to 15 mm)

**Application**

<b>ALFA ROMEO</b>	159, Sportwagon, Brera, Spider
<b>AUDI</b>	A3, TT
<b>BMW</b>	E90, E91, E92, E93 (335i)
<b>CITROËN</b>	C-Crosser
<b>FIAT</b>	Bravo
<b>FORD</b>	C-Max, Focus, Galaxy, Maverik, Mondeo, S-Max, Transit
<b>HYUNDAI</b>	H-1, I30, I30 Cw, Santa Fe, Sonata V, Tuscon
<b>LANCIA</b>	Delta
<b>MITSUBISHI</b>	Grandis, Outlander,
<b>OPEL</b>	Astra, Vivaro
<b>PEUGEOT</b>	4007
<b>RENAULT</b>	Espace, Laguna, Megane, Trafic, Vel Satis
<b>SEAT</b>	Altea, Altea Xl, Leon, Toledo,
<b>SKODA</b>	Octavia, Superb, Yeti,
<b>VOLVO</b>	S40, V50
<b>VW</b>	Caddy, Eos, Golf, Golf Plus, Jetta, Passat, Passat Cc, Scirocco, Touran

**GO** CODE **902**  
with 17 pcs. 0,6 kg  
**§ PATENTED**





## SELF ADJUSTING CLUTCH (SAC) MASTER SET



- Using a specialized tool is an absolute must for ensuring the proper installation of the self-adjusting clutch.
- It avoids erratic adjustment of the adjusting ring in the clutch's mechanisms and thereby ensures smooth operation of the clutch after installation.
- Depending on the flywheel's hole pitch grouping (six or eight screws), the pressure plate must be setup to work with the truss with the correct number of arms.
- New centering pin to BMW clutch.
- Included the adjustable face pin (Ø5 mm) spanner wrench. To remove the compression plate of clutch (e.g. FCA, VW Group).
- **The set is the best complete assortment on the market!**

### Components

1 x standard centering tool with guide and clamp components  
 2 x plastic clamping sleeves for the clutch disk hub, Ø15-28 mm  
 7 x centering pins for the pilot bearings Ø12-14-15-16-17-18-19 mm  
 1 x specialized centering tool set for BMW, 8 pieces including handle  
 (Ø15/23 - Ø15/26,5 - Ø15/26,5L - Ø15/28 - Ø15/32,5 -  
 Ø15/32,5L - Ø15/34 + guaina speciale per centraggio)  
 1 x specialized centering tool set with 2 clamping components, 14 pieces

1 x 3-piece pressure plate with centering expander and handle  
 2 x trusses for groups of 3 holes and 4 holes  
 12 x mounting bolts, 4 each M6, M7 and M8  
 4 x lock nuts for the mounting bolts  
 1 x extractor tool  
 1 x face pin (Ø5 mm) spanner wrench



<b>GO</b>	CODE	<b>907</b>
1	with 54 pcs.	kg 12,2 kg
<b>§ PATENTED</b>		



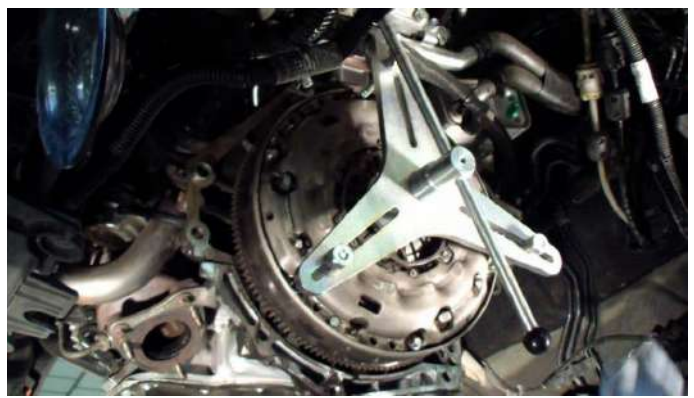
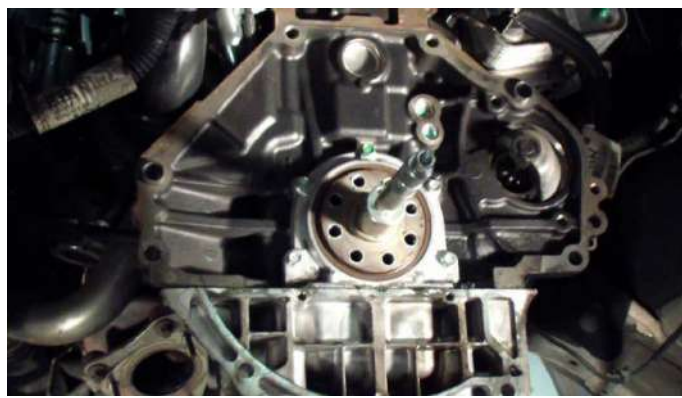

A	B	C
min. Ø15 mm max Ø27 mm	Ø15-21 mm Ø20-25 mm	Ø12 mm Ø14 mm Ø15 mm



## DSG CLUTCH TOOL SET "UPGRADE" VW GROUP



- Required for the professional disassembly and assembly of DSG clutches on VAG vehicles according to the manufacturer's workshop manual.
- New updated range, from model year 06/2011.
- Set includes tools for disassembly and assembly, calibration of a new DSG gearbox clutch pack and assembly of the clutch connection cover.

Code	OEM code	Description
A	T10323	Support bar
B	T10373	Clutch extractor (long version)
C	T10374	Setting gauge until 05/2011
D	T10376	Clutch pushing bush
E	T10303	Clutch security pin
F	T10302	Clutch cover guiding bush
G	T10407	Clutch assembly lever
H	T10466	Setting gauge from 06/2011

**Notice:** calibration is not necessary if the clutch is simply installed and removed. However, if the whole clutch is completely renewed, it needs to be recalibrated.

### Application

7-speed DSG (Code 0AM) up to 05.2011

7-speed DSG (Code 0AM) from 06.2011

7-speed DSG (Code 0CW) S-tronic

6-speed manual transmission (code 08D)

6-speed DSG wet (code 02E)

With VW/Audi/Seat and Skoda models from year of construction 2004

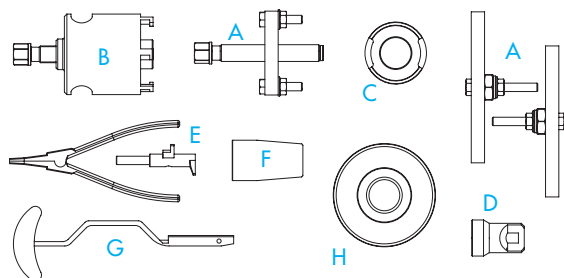

**GO** CODE **904**  
 1 with 11 pcs. **kg** 12,6 kg





## UNIVERSAL CLUTCH CENTERING TOOL SET



- Suitable for vehicles with and without pilot/pilot bearing an with front, rear and four wheel drive.
- There are two options for centering:
  - 1** Vehicles with pilot bearing: centering of the drive plate with the clutch unit in the removed state - subsequent assembly of the unit to the vehicle's flywheel.
  - 2** Vehicles without pilot bearing: centering the drive plate with the pilot bearing on the vehicle. (mainly vehicles with front drive and transverse engine).

### Applications

Passenger Cars, SUV, Offroader,  
Transporter, Light Commercial  
Vehicles

**GO** CODE **905**  
 with 18 pcs. 2,9 kg

Vehicles with pilot bearing



Vehicles without pilot bearing



## PILOT BEARING TOOL SET VW, FORD, MERCEDES



- Allows the removal of damaged and/or fixed clutch pilot bearings in confined spaces where the use of sliding hammers is difficult to impossible.
- Time saving solution!



### Components

- 1 x basic unit, L = 175 mm
- 1 x screw spindle with nut and washer, L = 10 mm
- 1 x adaptor (pull spindle-extractors)
- 1 x inner bearing spreader for Ø12-17 mm
- 1 x inner bearing spreader for Ø19-22 mm



### OEM code bearings

Ford	1096277 / YC1R7600-AA
Mercedes	018 981 25 10 / A 018 981 25 10
VW	076 105 313

**GO** CODE **909**  
 with 7 pcs. 1,6 kg



### Application

Ford: Transit Mk6, Ranger 2.2 / 2.4 / 3.2 from 04/2006  
 Mercedes-Benz: PKW, Transporter until the 01/2012  
 VW: ex.Crafter (2E,2F) from 2006, Touareg (7LA, 7L6, 7L7) until the 05/2013



UPGRADE



## SUPPORT FOR DETACHING AND REFITTING GEARBOXES AND AUTOMATIC TRANSMISSIONS



Even the front bar can be inclined of 5° in both directions, loosen the lower hexagonal screw on the main bar on the central part



- Universally applicable for gearboxes, automatic transmissions and DSGs as well as differential gears etc. The front and rear supports and arms, which can be adjusted in distance and tilt angle, provide a secure grip during application and removal.
- The support is applied to the gearbox which can be tilted forwards/backwards and right/left, always ensuring a secure grip.
- The tool include adapter for hydraulic gearbox lifter piston rod  $\varnothing 30\text{mm}$ .

To be used together with a hydraulic gearbox lifter, it is particularly practical and quick for detaching and refitting gearboxes, in particular those for automatic transmissions.



On request  
**GO1450, GO1451,**  
**GO1452, GO1453**

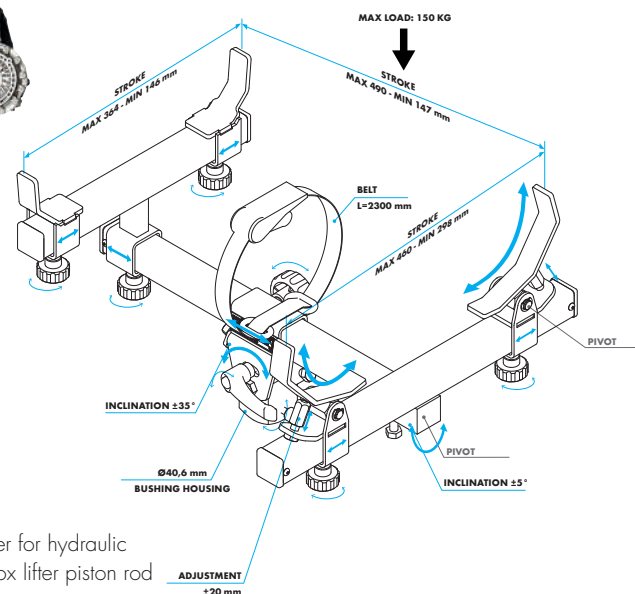

### Technical data

- Weight: 12 kg
- Max. load bearing capacity: 150 kg
- Length/width: 490 mm/460 mm
- Assembly:  $\varnothing 40$  mm
- Forwards/backwards tilt:  $\pm 35^\circ$
- Left/right tilt:  $\pm 5^\circ$

**GO**

CODE

**925**

with 2 pcs.

12 Kg

§ **PATENTED**

### Components

1 x support with arms for attachment to the gearbox, fixing strap included

1 x adapter for hydraulic gearbox lifter piston rod  $\varnothing 30\text{mm}$



## DRIVE SHAFT DISASSEMBLY TOOL RENAULT



**PLUS:**  
 OPTIMAL RELEASE  
 EFFECT

- With the help of this tool, it is possible to remove the drive shaft inserted in the gearbox.
- Firstly, the tool is inserted between the drive shaft and the gearbox. Then, with a slight slide hammer hit, the fixing circlip, found in the gearbox, is broken. Thus, the user can extract the drive shaft.
- The troublesome inclination of the fixing circlip is avoided by the fork central traction, allowing the user to easily unblock the drive shaft.



### Application

Renault: Twingo, Clio, Kangoo, Capture, Megane, Scenic, Talisman  
 Dacia: Sandero, Logan, Duster, Lodgi, Dokker  
 Ford, Mazda, Volvo etc.



CODE

**068**

1 with 6 pcs.

kg 5,5 kg





## DRIVE SHAFT DISASSEMBLY TOOL UNIVERSAL



- Designed to allow quick and safe removal of transmission-side drive shafts.
- Fits perfectly between gearbox and driveshaft for optimum contact and leverage on a wide range of vehicles including Ford, Volvo, Renault, Mazda and more



### Technical data

- Fork housing 55 mm
- Total length 404 mm
- Material High yield steel
- Handle Technopolymer resistant to organic and inorganic chemicals



### Application

Ford, Mazda, Volvo, Renault, Dacia

<b>GO</b>	CODE	<b>069</b>
<b>1</b>	with 1 pcs.	<b>kg</b> 1,2 kg



## CIRCLIP PLIER FOR DRIVE SHAFT UNIVERSAL

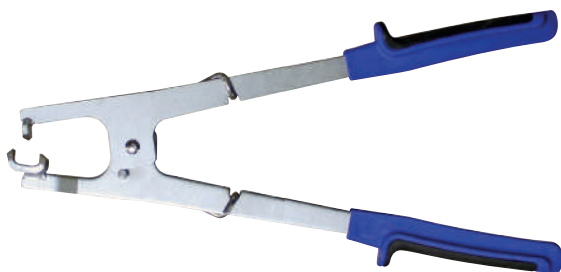

### Application

Audi, Ford, Honda, Mazda, Mitsubishi, Nissan, Opel/Vauxhall, Seat, Skoda, Subaru, Suzuki, Toyota, VW etc.

<b>GO</b>	CODE	<b>804</b>
<b>1</b>	with 1 pcs.	<b>kg</b> 0,4 kg

### Technical data

- Opening width max. 36 mm
- Length 300 mm

- To pre-tension the drive shaft circlip during assembly of the outer constant velocity joint.
- By holding the drive shaft circlip with the special circlip pliers, the outer drive shaft splines can be easily assembled into the CV joint.

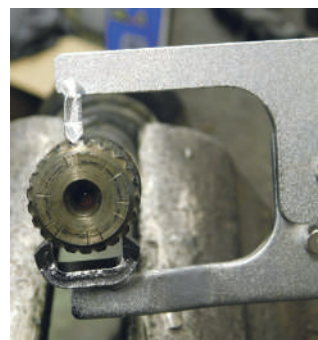



## G PLIERS FOR FITTING COLLARS WITHOUT ANY INDENTATIONS UNIVERSAL



### DESIGN:

Heavy-duty design with hardened tips and ergonomic handles.

- Special pliers for opening and closing earless flat clamps on drive shaft boots. E.g. Oetiker type 168 clamp.



### Technical data

- Material: hardened XC48 steel
- Weight: 350 g
- Length: 235mm
- The pliers close to a maximum of 2.5 mm



### Application

Not suitable for thermoplastic sleeves!

<b>GO</b>	CODE	<b>791</b>
<b>1</b>	with 1 pcs.	<b>kg</b> 0,35 kg

## G PLIERS FOR EAR CLAMPS UNIVERSAL



- For operations on particularly difficult to reach clamps on sleeves and hoses.

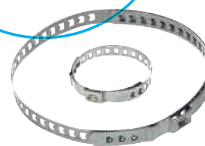

### Technical data

- Length 240 mm



### PLUS

What's special about these pliers is the lateral working method!

### Application

Fuel lines, radiator hoses, steering cowl, axle cowl, etc.

<b>GO</b>	CODE	<b>797</b>
<b>1</b>	with 1 pcs.	<b>kg</b> 0,34 kg

## G UNIVERSAL CIRCLIP PLIERS SET FOR DRIVE SHAFT

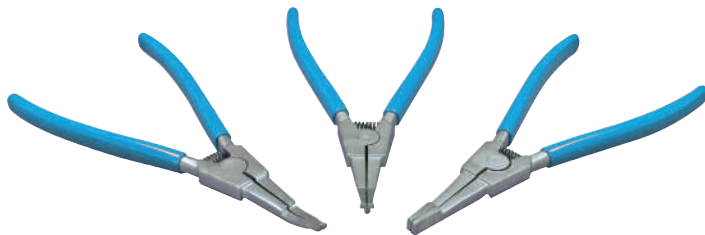

**GO** CODE **803**  
 1 with 3 pcs. **kg** 0,7 kg

Head picture	Pliers type	Heads plier	Length
	Plier 1	Head angled 30°	210 mm
		Pliers head with recess and ring trough	
		Self-closing	
	Plier 2	Head angled 10°	210 mm
		Pliers head with flat and knurled surface	
		Self-closing	
	Plier 3	90° head	210 mm
		wide flat shape with flat surface	
		Self-closing	

- Lock ring pliers set for assembly of locking rings on drive shafts.
- Special pliers with different head shapes for removing and installing external safety driveshafts rings without eyelet.
- Thanks to the slim design, it is easy to reach the rings in any position.
- Comfortable maneuverability thanks to the automatic closing mechanism!

## G UNIVERSAL PLIERS FOR DRIVE SHAFT CLAMPS



### Application

Audi, BMW, Chrysler, Citroën, Ford, GM, Honda, Mazda, Mercedes, Nissan, Opel, Porsche, Peugeot, Volkswagen etc.

- The pliers has been developed for opening and closing earless flat clips on axle boots, e.g. Oetiker stepless clamp type 168 **1**.
- The usage of the stronger stainless-steel clamps again requires high application of force which, due to the built-in transmission with the plier, can be easily applied by the mechanic.



**GO** CODE **799**  
 1 with 1 pcs. **kg** 0,3 kg

## G UNIVERSAL EAR CLAMP COLLET CHUCK



- The tool ensures an optimal fixing and secure hold of the clamp thanks to triple deformation of the ear. While the pliers head compresses the ear from left and right, the anvil moves upward, pressing and flattening the ear at the same time.
- Particularly robust design with high pliers' head precision and pressing force – important for pre-stamped clamps! (OE comparison number V.A.G. 1275A).

### Technical data

- Material:  
Head = Steel XC48  
punched Anvil = Steel XC42 forged - hardened
- Weight 450 g
- Length 230 mm



### Application

Vehicle area – axle boots as well as radiator and fuel hoses

**GO** CODE **798**  
 1 with 1 pcs. **kg** 0,3 kg

**G** CROWS FOOT OIL FILTER  
WRENCH FORD/PSA GROUP



- The usage of this wrench is highly recommended for mounting and dismantling oil filters plastic seat.
- This wrench has been designed to make work faster and easier, avoiding contact with wiring and intake system.
- The upper 1/2" connection of the wrench has to be used with a dynamometric wrench.
- As indicated on the plug, tighten it max at 25 Nm.

**Citroën application**

C4, Picasso, Grand Picasso, C5

**Ford application**

C-Max, Focus, Galaxy, Kuga, Mondeo, S-Max

**Peugeot application**

308, 3008, 508, 5008, 407, RCZ

Engine: 2.0 - 2.2 HDi/TDCi

Engine code: DW10C - DW12C

**GO** CODE **638**  
1 with 1 pcs. 0,5 kg



**G** CROWS FOOT OIL FILTER  
WRENCH FORD / PSA GROUP /  
JAGUAR



- Polygonal wrench 27 mm x 1/2" with switchable reversible head for dismantling and mounting oil filter plastic cover.
- Ideal to to unscrew the plastic oil filter cap, in case of lack of space.
- Integrated reversing lever.
- Working angle of the pawl adjustable to 90°.
- Steel polygonal loop for maximum grip during use.

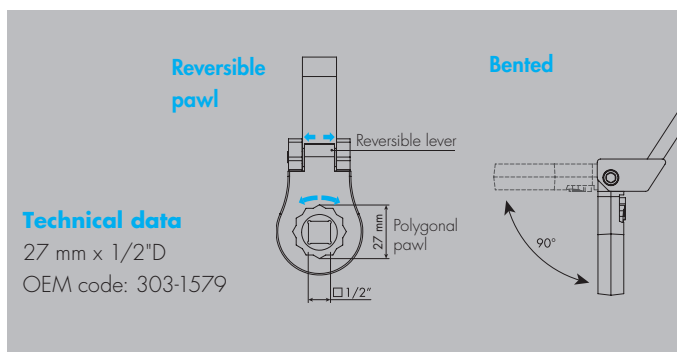

**Citroën application**

C4 Picasso, C5 Mk2, C5, C8, DS4, DS5

**Ford application**

Mondeo Mk3, C-Max/C-Max, Galaxy Mk3, Galaxy Mk2, S-Max, Kuga

**Peugeot application**

308, 3008, 5008, 407, 407 Coupé, 508, RCZ

**Jaguar application**

Jaguar, Jaguar XF

Engine: 2.0 16v HDi 163hp, 2.0 16v HDi, 2.0 HDi, 2.2 HDi GT, 2.0 HDi

Engine code: DW10 - DW12

**GO** CODE **639**  
1 with 1 pcs. 0,5 kg





## DIESEL FILTER WRENCH FOR FORD TRANSIT



- Wrench to remove the plastic cover on the fuel filter container. The 1/2" square drive allows the use of an extension and/or ratchet so as not to have to perform the loosening operation in the narrow space next to the filter.

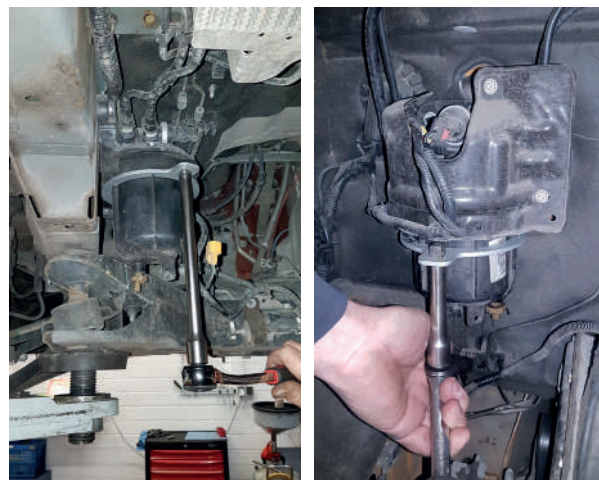

### Application

Ford Transit from year of construction 2006/2.2L Duratorq

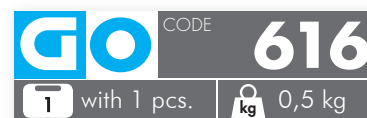

## OIL FILTER WRENCHES SET, WITH OIL DRAIN ADAPTOR VW GROUP



- The oil filter tool set with oil drain adaptor for VW allows the user to professionally drain the engine oil from the oil filter housing.
- Included the tools to open, drain and unscrew/tighten plastic oil filter housings.

### Use

- Undo the oil drain plug (SW37 mm or SW36 mm) on the plastic oil filter housing the oil drain plug socket.
- Screw oil drain adaptor into oil filter housing.
- This cause a valve to open allowing the oil to be drained in a controlled way.
- The empty oil filter housing can be easily unscrewed with the aid of the 74 mm oil filter socket.

### Components

1 x Oil filter wrench SW36, OEM VW T20160  
 1 x Oil filter wrench SW37  
 1 x Oil drain adaptor, OEM VW T40057  
 1 x Oil filter wrench; 74 mm - 14 flutes, OEM VW T20050

### Application

VW, Audi, Seat, Skoda 1.8 e  
 2.0 FSI, TFSI with plastic oil filter plugs.  
 Engine: AXW, BGB, BLX, BLR, BLY, BVX, BZY, BVZ, BWE

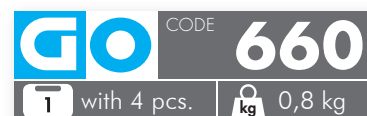



**GO** CODE **669**  
1 0,7 kg

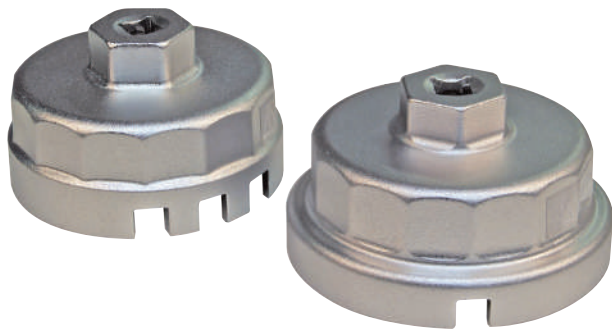

**GO** **612**  
1 0,6 kg



**GO** CODE **662**  
1  1,5 kg







**GO** CODE **629**  
 1 **kg** 0,3 kg



**GO** CODE **620**  
 1 **kg** 0,1 kg



**GO** CODE **622**  
 1 **kg** 0,2 kg



**GO** CODE **623**  
 1 **kg** 0,2 kg



**GO** CODE **626**  
 1 **kg** 0,2 kg



**GO** CODE **659**  
 1 **kg** 0,2 kg

**NEW**



**GO** CODE **661**  
1  0,2 kg



**GO** CODE **673**  
1  0,2 kg



**GO** CODE **678**  
1  0,2 kg



**GO** CODE **656**  
1  0,3 kg



**GO** CODE **657**  
1  0,2 kg



**GO** CODE **654**  
1  0,2 kg



**GO** CODE **621**  
 1 0,2 kg



**GO** CODE **665**  
 1 avec 1 pcs. 0,2 kg



**GO** CODE **667**  
 1 0,2 kg



**GO** CODE **658**  
 1 0,3 kg



**GO** CODE **652**  
 1 0,2 kg



**GO** CODE **670**  
 1 0,2 kg





**GO** CODE **631**  
1 0,2 kg



**GO** **643**  
1 0,2 kg



**GO** **644**  
1 0,2 kg



**GO** **675**  
1 0,2 kg



**GO** CODE **634**  
1 0,2 kg



**GO** **635**  
1 0,3 kg



**GO** **632**  
 1 0,2 kg



**GO** **633**  
 1 0,2 kg



**GO** CODE **682**  
 1 0,2 kg

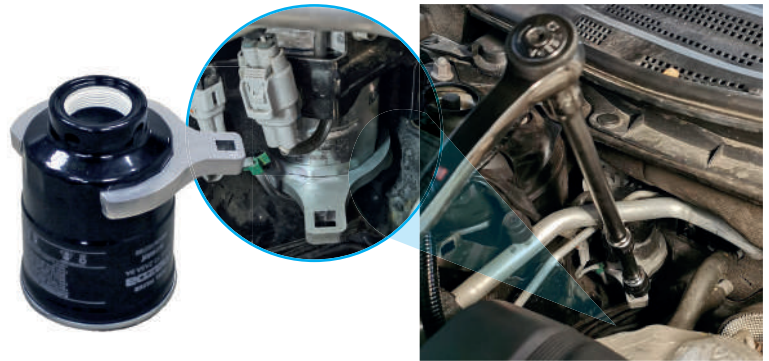

**GO** **680**  
 1 0,5 kg



**GO** **672**  
1 0,3 kg



**GO** CODE **627**  
1 0,2 kg



**GO** CODE **664**  
1 0,2 kg



**GO** CODE **655**  
1 0,2 kg



**GO** CODE **663**  
1 0,2 kg



**GO** CODE **679**  
1 0,14 kg



**GO** CODE **625**  
 1 0,2 kg



**GO** CODE **628**  
 1 0,2 kg



**GO** CODE **630**  
 1 0,3 kg



**GO** CODE **624**  
 1 0,2 kg



**GO** CODE **653**  
 1 0,3 kg



**GO** CODE **674**  
 1 0,4 kg





**GO** CODE **684**  
 1 kg 0,20 kg  
 § PATENTED



**Ø 80-100 MM**  
**GO** CODE **676**  
 1 kg 0,94 kg

**Ø 60-80 MM**  
**GO** CODE **681**  
 1 kg 0,94 kg



**Ø 60-80 MM**  
**GO** CODE **605**  
 1 kg 0,83 kg



## FUEL FILTER WRENCH FOR FORD CUSTOM 2.0 TDCI, Ø 32



- Socket wrench required to remove the diesel filter element (Ford filter OEM 2005485) from its housing.
- The special design, with a recess for the fuel drain valve, fits perfectly and ensures a secure grip.

### Application

Motore Ford Transit Custom (MK 8),  
2.0 TDCi dal 2016

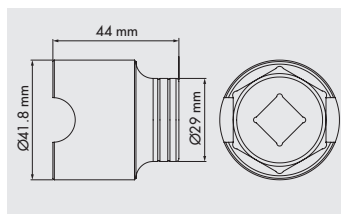

### Technical data

- Dimensions CH32
- Connection - 1/2"

<b>GO</b>	CODE	<b>536</b>
<b>1</b>	with 1 pcs.	<b>kg</b> 0,2 kg



## FUEL FILTER WRENCH FOR MAZDA 1.5L DIESEL ENGINE, FORD



- Allows non-slip detachment of the fuel filter.
- The version with extra depth picks up the protruding vent screw and engages the drive profile of the metal filter cartridge.



### Application

Mazda 2 1.5L diesel (DJ6H) from 2014  
Mazda CX 3 1.5L turbo diesel (DKEW, DKFW) from 2015  
OEM filter S51C 13 ZA5A

### Technical data

- Profile Ø 57 mm / pitch 12
- 3/8" + SW27 mm
- Material aluminium

<b>GO</b>	CODE	<b>677</b>
<b>1</b>	with 1 pcs.	<b>kg</b> 0,5 kg



## OIL DRAIN PLUG REPAIR INSERT RANGE UNIVERSAL



**Fast, professional and simple solution saves the replacement of the oil pan!**



- To replace the original oil drain plug if the thread in the oil pan is damaged.
- Use of the repair oil drain plug.
- The repair oil drain plug consists of two parts. The outer part is equipped with the original oil drain plug thread. The thread is slightly conical, which ensures a firm and tight connection, even with damaged oil pan thread. This connection does not have to be opened at later oil changes. From now, oil is drained on the small central screw. A small supply of commercially available copper or O-rings for later oil changes is already included.

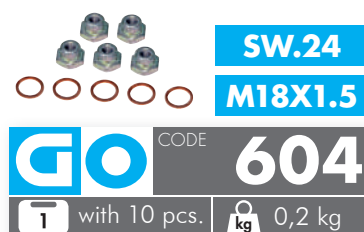
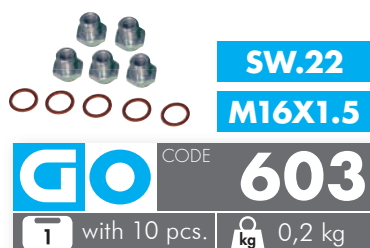
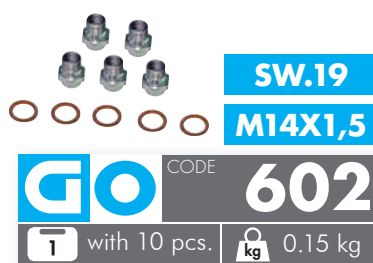

### Components

- 3 x repair oil drain plug conical, M12x1.5
- 3 x repair oil drain plug conical, M14x1.5
- 3 x repair oil drain plug conical, M16x1.5
- 3 x repair oil drain plug conical, M18x1.5
- 1 x copper sealing rings Ø10 mm (25 pcs.)
- 1 x O-rings Ø1 / 4" (5 pcs.)

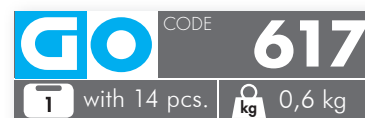



## SET OF SPECIAL WRENCHES FOR PLASTIC OIL DRAIN PLUGS - VEHICLES



- This set contains the most common special socket wrenches for plastic oil drain plugs.
- Precise fit profile allows for undamaged loosening and tightening according to manufacturer's specifications.
- Includes practical T-handle key with double internal 3/8 inch guide x 6 external SW17 sides.

### Screw models

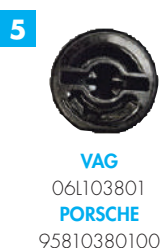

### Components

- 1 socket wrench with 3 drivers
- 1 x External Hex Socket Wrench
- 1 x External Socket Wrench Slot
- 1 x Internal Double Socket Wrench Slot
- 1 x 3/8" Square T-handle Wrench

### Application

Ford/Peugeot/Citroen/Lincoln/Opel/Vauxhall Toyota/Mercedes/BMW/VW/Seat/Skoda/Seat/Porsche

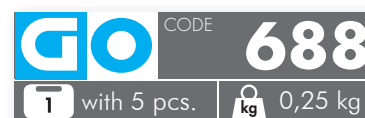



## G UNIVERSAL TOOL FOR THE REMOVAL OF HENN CLAMPS, ADJUSTABLE



### Application

Universal use on vehicles – SUVs - Vans and Motorcycles  
 E.g.: VAG, Volvo, Toyota/Lexus, PSA, Ford, Mercedes, BMW, Nissan, Fiat, Mazda, Renault/Dacia, Kia etc.



- Special tool to release/loosen the Henn clamps to a professional standard.
- Model with adjustable head, allows access even in areas difficult to reach.
- The Henn clamps are used in the automotive sector on the water pipes in the cooling system and in the radiators.

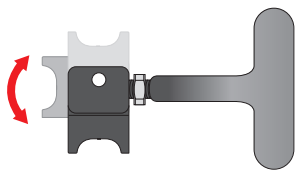

### Technical data

- Head can be adjusted 90° to the left and to the right and can be locked.
- Total length 95 mm



**GO** CODE **810**  
 with 1 pcs. 0,15 kg

## G UNIVERSAL PLIER FOR HOSE CLAMPS



- Used to install and remove collars on exhaust pipes.
- Rotatable jaws **A** allow the clamp to be universal.
- Hose clamp pliers with Micro ratchet system **B**.
- Extra long version.

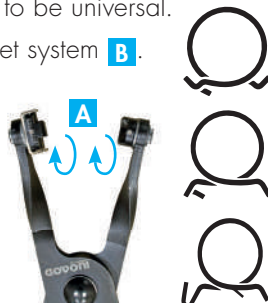

### Technical data

- Material: XC48 (arms) - 35MF6 (jaws)
- Length: 290 mm (plier) - 70 mm (arms)

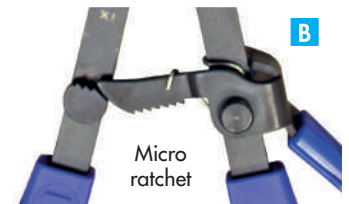

**GO** CODE **808**  
 with 1 pcs. 0,3 kg

Hose clamp type	Ø	Width	Grip type
MUBEA (Muh & Bender)	Ø18-54 mm	12+15 mm	1-K Injection
NORMA			(Optional 2-K)



## UNIVERSAL SOK SOCKETS SET



- The SOK sockets are designed to open the SOK-FBS clamps.

### Technical data

- Socket straight: L = 125 mm
- Socket 90°: L = 110 mm

### Application

SOK-FBS clamps type II and type III.  
Universal for car and transporter.

<b>GO</b>	CODE	<b>806</b>
<b>1</b>	with 1 pcs.	<b>kg</b> 0,4 kg



## UNIVERSAL PLIER FOR CLIC, CLIC-R AND CLIC-E HOSE CLAMPS



- The shape of the arms makes gripping easier.
- A spring makes it possible to open systematically the pliers after tightening the CLIC.
- Change from opening to closing function by turning the pliers by 180°.
- Self-opening - ergonomic handles with color to identify the opening and closing function.

### Technical data

- Steel XC48 material
- Hardness 50-54 HRC
- Length 180 mm



### CLAMPS TYPE

Clic (55, 56, 86)  
Clic R (R66, R86, R96)  
Clic E

### Application

Fuel lines, air filters, steering, drive shaft sleeves, as well other industries and electrical household appliances



<b>GO</b>	CODE	<b>807</b>
<b>1</b>	with 1 pcs.	<b>kg</b> 0,2 kg



**REAR DRIVE MOTOR COOLANT RESERVOIR  
REMOVAL SOCKET AUDI**

**NEW**



- Specially designed cup socket used to remove and refit the coolant leakage container (expansion tank) without causing damage to the rear drive motor on the Audi e-tron, at the required service intervals recommended by the vehicle manufacturer.



**PLUS**

Manufactured from non-conducting nylon composite to help prevent damage to the vehicle component.



**GO** CODE **077**  
 with 1 pcs. 1,10 Kg

**Technical data**

- Flutes: 12; 60mm diameter.
- Use with 27mm single hex socket.

**Application**

Equivalent to OEM T40409. Designed to fit leakage container OEM 0EF901257C.



**TOOL FOR INSTALLING WATER  
PUMP STRETCH BELT WITHOUT  
BELT TIGHTENER PSA/OPEL**



- Tool for installing water pump stretch belt without belt tightener. For use for PSA and Opel group vehicles engines 1.0 - 1.2.



**AIR CONDITION BELT  
INSTALLATION TOOL FOR BMW  
N62 / MINI W17**

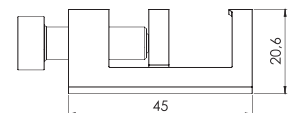
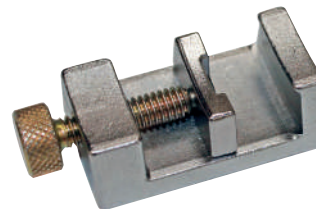

- For installation of stretch belts (drive belts without tensioner) suitable for stretching belts on BMW N62 (V8) (2004-2006) and MINI W17 (Diesel)

Application			
PEUGEOT	108, 208, 301, 308, 408, 2008, 3008, 5008, Partner	2012	1.0L and 1.2L 3-cylinder engines
CITROËN	C1, C2, C3 Picasso, C3 Aircross, C4, C4 Picasso, C4 Cactus, C-Elysee, Berlingo, DS 3, DS4, DS 4S, DS 5LS		
VAUXHALL/OPEL	Crossland X		

**GO** CODE **916**  
 with 1 pcs. 0,10 kg



Application		
MINI	To be used as OEM2	64 1 040
BMW	To be used as OEM1	

**GO** CODE **919**  
 with 1 pcs. 0,10 kg





## PLIERS FOR HOSE CLAMPS 302 MM

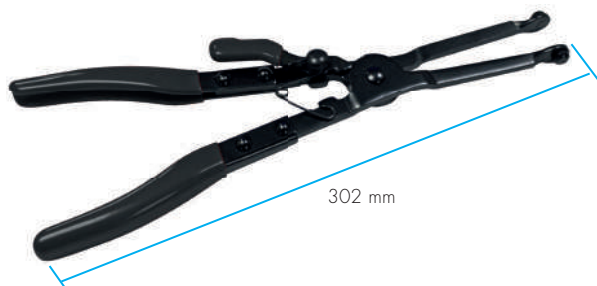

### Technical data

- 4 locking positions
- Tightening from 20 - 60 mm
- Coated handle
- With locking
- Automatic opening

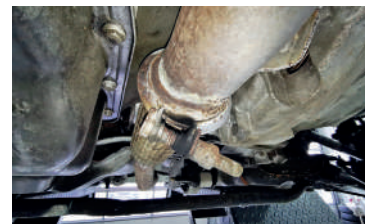

### Application

<b>CITROËN</b>	OE 1713.52; OE 1713.66
<b>PEUGEOT</b>	OE 1713.52; OE 1713.66
<b>FORD</b>	OE 1875 271

<b>GO</b>	CODE	<b>685</b>
<b>1</b>	with 1 pcs.	<b>kg</b> 0,45 kg



## WRENCHES FOR NO<sub>x</sub> AND PARTICULATE MATTER SENSORS 14/17/19/22/24 MM



- Allows professional disassembly and assembly of exhaust particle NO<sub>x</sub> sensors.
- The closed 6-point profile allows very high loosening torques, especially with an extremely locked coupling.
- The special design of the special socket wrench prevents slipping and damage of the wrench profile on the sensor.
- The connection cable is led to the side of the wrench and is therefore protected from cuts and incisions.

Particle Sensor

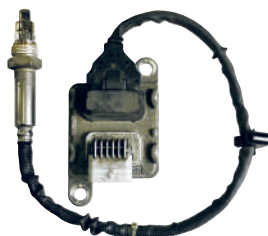

Sensor in the wrench insert



Sensor with wrench insert and socket



### Technical data

- Total length 85 mm
- 1/2" guide

<b>GO</b>	CODE	<b>700</b>
<b>1</b>	with 7 pcs.	<b>kg</b> 2,5 kg



**G** SET OF WRENCHES FOR  
TEMPERATURE SENSORS (REMOVAL)  
14 MM, 17 MM, 19 MM



**G** SET OF WRENCHES FOR NOx AND  
LAMBDA SENSORS (REMOVAL)  
22 MM, 24 MM



- Allows professional disassembly and assembly of exhaust particle NOx sensors.
- The closed 6-point profile allows very high loosening torques, especially with an extremely locked coupling.
- The special design of the special socket wrench prevents slipping and damage of the wrench profile on the sensor.
- The connection cable is led to the side of the wrench and is therefore protected from cuts and incisions.



**Components**

- 1 x 24mm Socket Wrench
- 1 x 19mm Socket Adapter
- 1 x 17mm Socket Adapter
- 1 x 14mm Socket Adapter



**Components**

- 1 x 32 mm Socket Wrench
- 1 x 22 mm Socket Adapter
- 1 x 24 mm Socket Adapter

**Technical data**

- Total length 85 mm
- 1/2" guide

**GO** CODE **698**  
T with 4 pcs. **kg** 1,04 kg



**Technical data**

- Total length 85 mm
- 1/2" guide

**GO** CODE **699**  
T with 3 pcs. **kg** 1,16 kg



## MASTER KIT NO<sub>x</sub> SENSOR REPAIR, SONDA LAMBDA

**NEW**



- Kit useful for assembling, disassembling, cleaning and restoring the thread of the NO<sub>x</sub> sensor/ lambda sensor seat.
- In most cases it avoids replacing the catalyst of the exhaust system.

**GO** CODE **800-X**  
 with 23 pcs. 1 Kg

- ASSEMBLY
- DISASSEMBLY
- THREAD CLEANING
- THREAD RESTORATION



## NO<sub>x</sub> SENSOR REPAIR KIT, SONDA LAMBDA

**NEW**



- Kit useful for assembling, cleaning and restoring the thread of the NO<sub>x</sub> sensor/ lambda sensor seat.
- In most cases it avoids replacing the catalyst of the exhaust system.

**GO** CODE **800**  
 with 20 pcs. 1 Kg

- ASSEMBLY
- THREAD RESTORATION
- THREAD CLEANING





## EXHAUST GAS TEMPERATURE SENSOR SW.19-1/2", RENAULT, DACIA

**NEW**



- Necessary to install the exhaust gas temperature sensor on several Renault models without damage.
- The cable can be removed from the side thanks to the longer slot without being damaged.

### Application:

- Renault: Capture, Clio IV, Scenic III, Kadjar, Kangoo, Megane III+IV, Trafic III;
- Dacia: Dokker, Duster + Duster II, Lodgy +Lodgy II, Logan MCV II, Sandero II;
- Engine codes: K9K/R9M (1,5 dCi + 1,6dCi)
- es: Renault sensor OEM 226589153R
- as well as Nissan/ Fiat/ Mitsubishi

### Technical data

- Double drive 1/2" + SW 19
- Length type 1 85mm
- Length type 2 115mm
- Width across flats SW14

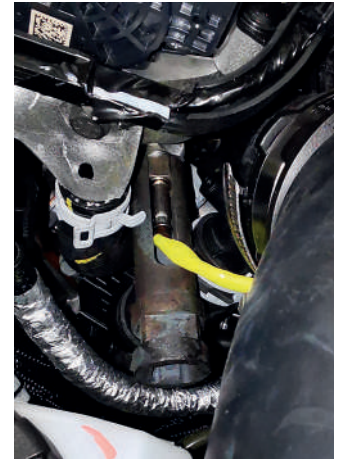

CODE

**796**

**T** with 2 pcs.

**kg** 0,38 Kg



## NOx INSERT FOR SENSOR

**NEW**



VW GROUP

SW.19



VW GROUP

SW.17

### Application

- 2.0 TDI CR: 110KW/135KW dal 2017



CODE

**683**

**T** with 1 pcs.

**kg** 0,06 Kg

- Necessary to remove the temperature sensor without damaging it.
- It can be used only after having removed the toothed belt cover.

### Application

- VAG da 1,6 L OEM Nr.: VW AG906 088 DK



CODE

**692**

**T** with 1 pcs.

**kg** 0,06 Kg



## 1/2" LAMBDA PROBE SOCKET, GROOVED 24 MM



## 1/2" LAMBDA PROBE SOCKET, GROOVED 22 MM

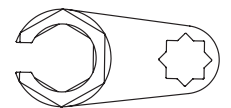
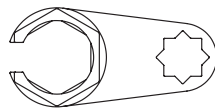

CODE

**694**

**T** with 1 pcs.

**kg** 0,24 kg

- It allows the disassembly and assembly of the lambda probe, NOx and exhaust particulate matter sensors.
- Its double 1/2 inch square drive allows quick repositioning.



CODE

**695**

**T** with 1 pcs.

**kg** 0,24 kg



**G** MALE SET AND MAGNETIC MALE HOLDER ADAPTER  
**M12X1.25**



**G** MALE SET AND MAGNETIC MALE HOLDER ADAPTER  
**M14X1.5**



- The set consists of a male and a magnetic male holder adapter with locking ball for ratchet wrench.
- The operation of the males can be carried out by means of a screwdriver or socket wrench.

**GO** CODE **956**  
with 2 pcs. 0,15 kg

**Technical data**  
• 7.2mm Magnetic Adapter

**GO** CODE **957**  
with 2 pcs. 0,15 kg

**Technical data**  
• 9.2mm Magnetic Adapter

**G** NO<sub>x</sub> SENSOR HOLE THREAD RESTORER MALE



- This tool is universally used for light and heavy diesel engines, this tool allows you to professionally restore the thread of the NO<sub>x</sub> sensor hole without damaging the exhaust system.
- The tool is equipped with an alignment guide at the front of the male threader to ensure a correct angle. With an extra short body, the tool can be used with a socket wrench or ratchet wrench in tight spaces.
- Optimal for cleaning and regenerating threads up to the end of the thread/ stop blind hole.

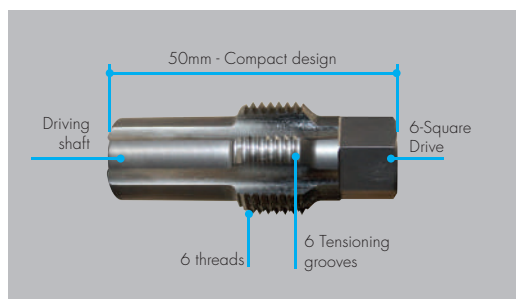

**Technical data**  
• Square Drive: SW 13 mm  
• Length: 50 mm  
• Tensioning grooves: 6  
• Material: HSCO

**GO** CODE **958**  
with 1 pcs. 0,9 kg

**M20X1.5**



**GO** CODE **959**  
with 1 pcs. 0,9 kg

**M22X1.5**







## NO<sub>x</sub> SENSOR HOLE MALE RESET THREAD, TEMPERATURE SENSOR

**NEW**

**M12X1,25**

**L=55 MM**



CODE

**961**

**T** with 1 pcs.

**Kg** 0,04 Kg

**M14X1,5**

**L=45 MM**



CODE

**962**

**T** with 1 pcs.

**Kg** 0,04 Kg

**M18X1,5**

**L=42 MM**



CODE

**963**

**T** with 1 pcs.

**Kg** 0,04 Kg

- This tool is universal in use for light and heavy duty diesel engines, and it allows to professionally re-thread the NO<sub>x</sub> sensor thread without damaging the exhaust system.
- Excellent for cleaning and regenerating threads up to the end of the threaded blind hole.
- Additional sizes to the ones already on our range **GO958** e **GO959**

### Technical data

- Compact design
- hexagonal drive SW13 and driving shaft
- Excellent for cleaning and regenerating threads
- Excellent up to the end of the threaded blind hole.
- Optimum result thanks to  $\phi$  tensioning grooves
- Material = HSCO

### Application

Exhaust particle sensors, exhaust temperature sensors, lambda sensors, etc.

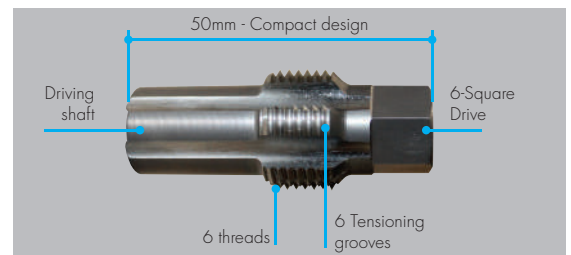

**M16X1,5**

**L=43 MM**

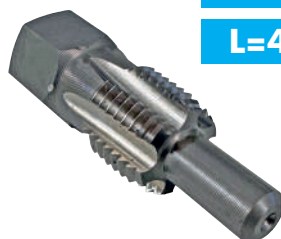

CODE

**965**

**T** with 1 pcs.

**Kg** 0,04 Kg

**M18X1,5 SW. 20**



CODE

**964**

**T** with 2 pcs.

**Kg** 0,16 Kg



### Application

Iveco Eurocargo, Stalis, Trakker and Crossway = Bus



## COMPRESSION TESTER FOR DIESEL ENGINES 8 - 40 BAR, UNIVERSAL



FAKE GLOW PLUGS TYPE			
CODE	A	B (mm)	C (mm)
N. 12	M10x1	63	22,5
N. 13	M8x1	83	54
N. 14	M10x1	86	58
N. 15	M10x1	55	14
N. 16	M8x1	76	46
N. 17	M10x1	56,5	102,5
N. 18	M10x1	90	64
N. 19	M8x1	83	59
N. 20	M9x1	193	76
N. 21	M10x1	48,5	23
N. 22	M10x1	73	41
N. 23	M10x1	22,5	59
N. 24	M8x1	75,5	103,5
N. 25	M10x1	30	58
N. 26	M10x1.25	30,5	99
N. 27	M10x1.25	54	89
N. 28	M8x1	72,5	43,5

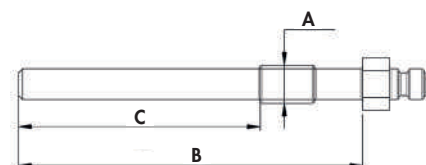

- Set designed for diesel engines, with a complete array of fake glow plugs and fake injectors.
- A professional tester, for engines compression status, is included.
- The compression test provides significant information regarding the engine conditions.
- The test must be executed when the engine performances are reduced or if irregular ignitions, not attributed to the power system, are being verified.
- The engine condition can be discovered observing the progress of the needle during the test, or, analysing the diagram produced at the end of the test.
- Furthermore, thanks to the diagram produced during the test, the customer can see the actual condition of the engine.

Adapters for glow plugs



Adapters for injectors



### Application

<b>ALFA ROMEO</b>	147, 156, 159, 166, Brera, Giulietta, GT, Mito, Spider
<b>AUDI</b>	A1, A2, A3, A4, A5, A6, A7, A8, Q3, Q5, Q7, TT
<b>BMW</b>	Serie 1, 2, 5, 6, 7, X3, X5, X6
<b>CITROËN</b>	Berlingo, C1, C2, C3, C3 Picasso, C4, C4 Gran Picasso, C4 Picasso, C5, C6, C8, Dispatch, DS4, Jumper, Nemo, Xsara, Xsara Picasso
<b>DACIA</b>	Duster, Logan, Sandero
<b>DODGE</b>	Avenger, Caliber
<b>FIAT</b>	500, 500C, Bravo, Croma, Doblò, Fiorino, Grande Punto, Idea, Linea, Multipla, Panda, Punto, Punto Evo, Qubo, Scudo, Sedici, Siena, Stilo, Strada
<b>FORD</b>	B-Max, C-Max, Fiesta, Focus, Focus C-Max, Fusion, Galaxy, Kuga, Mondeo, S-Max, Tourneo Connect, Transit, Transit Connect
<b>HONDA</b>	Civic
<b>JAGUAR</b>	S-Type, XJ, XType
<b>JEEP</b>	Commander, Compass, Grand Cherokee
<b>LANCIA</b>	Musa, Thesis, Ypsilon
<b>LAND ROVER</b>	Defender, Discovery, Freelander, Range Rover, Range Rover Sport
<b>MAZDA</b>	2, 3

<b>MERCEDES</b>	Classe A, B, C, CLK, Classe E, GL, ML, R, S, Sprinter, Viano, Vito
<b>MINI</b>	One, Cooper, Clubman, Countryman, Coupe, Paceman, Roadster
<b>MITSUBISHI</b>	Carisma, Grandis, Outlander
<b>NISSAN</b>	Almera, Juke, Kubistar, Micra, Note, NV200, Pirmera, Qasqai, Tiida
<b>PEUGEOT</b>	107, 206, 207, 208, 307, 308, 407, 508, 607, 807, 1007, 3008, 5008, Bipper, Boxer, Expert, Partner, RCZ
<b>PORSCHE</b>	Cayenne, Panamera
<b>RENAULT</b>	Clio, Espace, Grand Scenic, Kangoo, Laguna, Master, Megane, Modus, Scenic, Thalia, Traffic, Twingo, Vel Satis
<b>SEAT</b>	Alhambra, Altea, Altea XL, Cordoba, Exeo, Ibiza, Leon, Toledo
<b>SKODA</b>	Fabia, Octavia, Roomster, Superb, Yeti
<b>SUZUKI</b>	Grand Vitara, Ignis, Jimmy, Liana, Sash, Swift, SX4, Wagon R+
<b>TOYOTA</b>	Auris, Aygo, Corolla, Yaris,
<b>OPEL/VAUXHALL</b>	Agila, Astra, Combo, Corsa, Insignia, Meriva, Movano, Signum, Vectra, Vivaro, Zafira
<b>VOLKSWAGEN</b>	Amarok, Bora, Caddy, Crafter, Eos, Fox, Golf, Golf Plus, Jetta, LT, Lupo, Multivan, Beetle, Passat, Passat CC, Phaeton, Polo, Scirocco, Sharan, Tiguan, Touareg, Touran, Transporter

**GO** CODE **535**  
with 31 pcs. **kg** 10,2 kg



## ABOVE ENGINE SUPPORT UNIVERSAL, MAX 500 KG



Height, incline, position, width and the arms angle are adjustable!



- Upper engine support designed to ease the engine being lifted while is positioned on the vehicle front axle.
- The equipped chain allows fixing the engine, granting security and a firmly hold (500 kg max).
- This tool is ideal when dismantling the subframe is rather laborious, especially when the operator has to use a lower support (transmission jack...).
- The tool is equipped with a 4-wheel support system, adjustable in height, manufactured in scratch-resistant and slip-resistant material, assuring great stability and avoiding dangerous overturning.
- Versatile lateral bars and support feet, adjustable in height, position, inclination and angle, granting the tool to be applied on numerous vehicles.

### Technical data

- Capacity max. 500 kg
- Weight: 20,5 kg – 1 pcs
- CE approved machine in compliance with 2006/42/CE (Machine Directive)

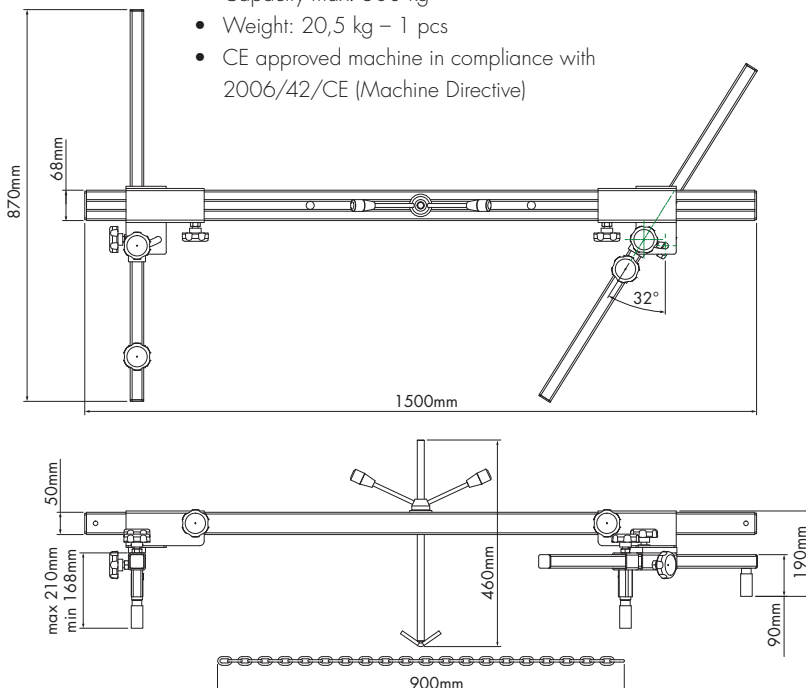

### Components

- 2 x lateral bars L=87 cm Rotation 32°
- 4 x adjustable support foot H=min 9 - max 21 cm
- 1 x lifting threaded bar L=46 cm
- 1 x chain L=90 cm
- 1 x bar frame L=1,5 m



CODE

650

1 with 1 pcs.

kg 18,7 kg

## **+** SUPPLEMENTARY ADJUSTMENT FOOT SET



- It allows the application of the support on long bars or deep auxiliary frames in the engine compartment, as well as on a shock absorber head, located deep behind the partition bulkhead of the engine compartment/water dripper.
- The tool **IS REQUIRED AS A SUPPLEMENTARY KIT TO THE GO650** and earlier versions.



### Components

- 2 x Leg Support-Extension 50mm
- 2 x Leg Support Extension 50-100mm, Adjustable
- 2 x Support Legs Telescopic Extension 270-540mm, Adjustable

<b>GO</b>	CODE	<b>696</b>
<b>1</b>	with 6 pcs.	<b>kg</b> 2,5 kg

## **G** MANUAL ENGINE SUPPORT 330 KG



- It should be positioned on the wheel arches, adjusting the length by means of the appropriate side arms.
- It is designed to fit on the wheel arch of any type of vehicle thanks to the possibility of inclination of the side supports.
- Designed for servicing: gearbox, clutch, valve timing, replacement of engine mountings, engine oil seals, and bodywork.

### Technical data

- Extended width: min. 700 mm / max. 1.480 mm
- Capacity: 330 kg
- Length: 1.5 m
- CE approved machine in compliance with 2006/42/CE (Machine Directive)

<b>GO</b>	CODE	<b>648</b>
<b>1</b>	with 1 pcs.	<b>kg</b> 13,3 kg

**STANDARD VERSION**

### Technical data

- Extended width: min. 700 mm / max. 1.720 mm
- Capacity: 330 kg
- Length: 1.75 m
- CE approved machine in compliance with 2006/42/CE (Machine Directive)

<b>GO</b>	CODE	<b>649</b>
<b>1</b>	with 1 pcs.	<b>kg</b> 14,7 kg

**LONG VERSION**





## ENGINE AND GEARBOX SUPPORT UNIVERSAL, 240 KG

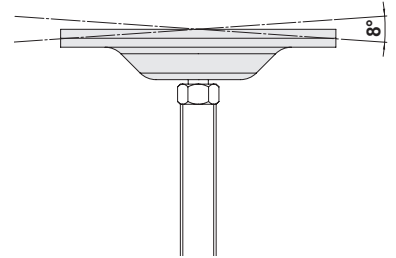

The supporting base, it's adjustable in height and it floats up to 8° to match perfectly to the engine/gear surface. It's covered with a non-slip rubber

- This special device allows to support the engine when the side engine bracket is removed, e.g. during maintenance work on thrust bearings, timing belts, water pumps or tensioner rollers.
- Equipped with two sliding hooks to fit to underbody of vehicles.
- After loosening the engine mount, the engine support safely holds the vehicle engine in the engine compartment (time savings and higher safety at work).
- Thanks to this device, it is possible to work at the engine control (belt drive) without using engine cranes or transmission lifts, the engine compartment is freely accessible.

### Technical data

- Telescopic arm (to 230 mm).
- Load capacity 240 kg
- Sliding telescopic arm extension: min. 657/max 887.
- Side-arms extension: min. 322/max 566.
- Arms rotation of 360°; the device can be closed completely in order to be stored in small spaces.

- The two supporting feet are adjustable in height to the vehicle frame, with the support components covered with polyurethane.
- CE approved machine in compliance with 2006/42/CE (Machine Directive).



### INCLUDED:

the tool that allows to place the device firmly and balanced on a jack lift



**GO** CODE **640**  
 1 with 1 pcs. 11 kg  
 § **PATENTED**

**STANDARD**



**GO** CODE **646**  
 1 with 1 pcs. 12 kg  
**PATENTED**

GO1450/GO1451  
optional

**PLUS**



## ENGINE AND GEARBOX SUPPORT UNIVERSAL, 400 KG



### Features

The two supporting feet are adjustable in height to the vehicle frame, with the support components covered with polyurethane

The supporting base, it's adjustable in height and it floats up to 8° to match perfectly to the engine/gear surface. It's covered with a nonslip rubber

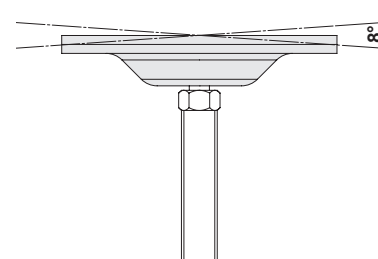

- This special device allows to support the engine when the side engine bracket is removed, e.g. during maintenance on timing belts, water pumps or tensioner rollers. Equipped with two sliding hooks to fit underbody on every vehicle.
- After loosening the fastenings, the device safely holds the vehicle engine in its compartment (time savings and higher safety at work).
- Thanks to this device, it is possible to work at the engine control (belt drive) without using engine cranes or transmission lifts, the engine compartment is freely accessible.



### Technical data

- Telescopic arm: to 230 mm
- Load capacity: max 400 kg
- Sliding telescopic arm extension: min.657/max 887
- Side-arms extension: min.322/max 566

- Arms rotation of 360°; the device can be closed completely in order to be stored in small spaces
- CE approved machine in compliance with 2006/42/CE (Machine Directive)

CODE
647

1
with 1 pcs.
kg
16 kg

§
PATENTED

# G VALVE SPRING COMPRESSOR 500KGF

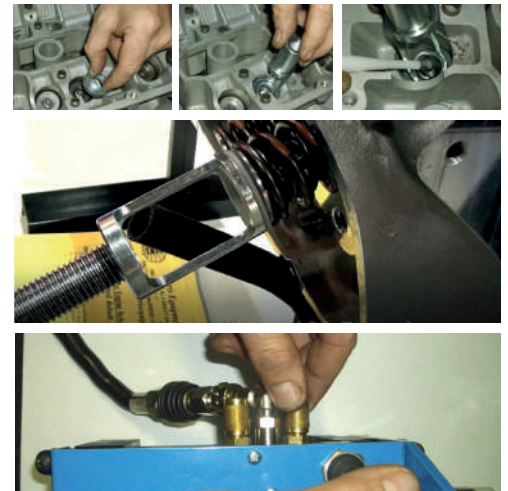
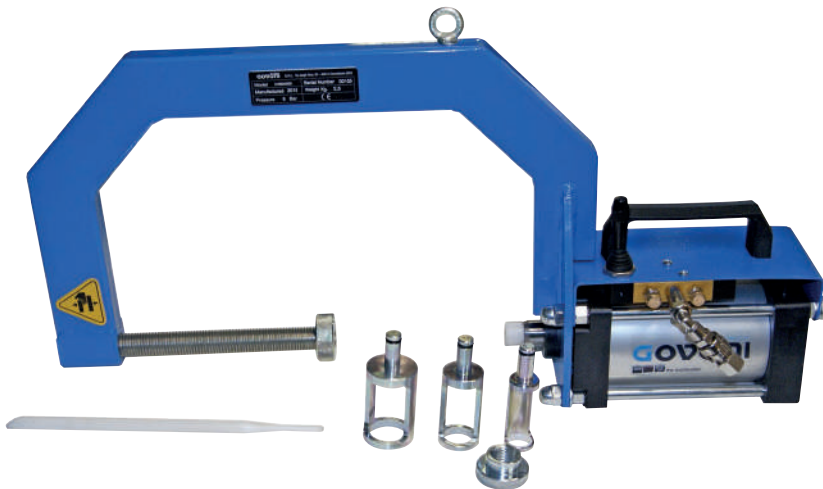

- Operates on springs from 19 mm. to 50 mm. (3/4" to 2") diameter. Quick and precise adjustment in millimeters increments thanks to its locking handle.
- Cylinder stroke is 90 mm. (3" 1/2) to provide compression of any spring type whilst protecting the user.
- It needs only 6 bar (90 psi) of compressed air to operate. With a working pressure of 10 bar (145 psi) the Spring Compressor force is 500 kgf (1.102 lbf).
- The cylinder is made in light alloy and nylon resin with fiberglass, avoiding the corrosion and the oxidation of the parts of the machine.
- Heavy-duty frame is CNC-machined and made of quality steel.
- The drive valve can function only when the Spring Compressor is connected to the compressed air system. Consequently the machine can be disconnected while the spring is compressed without dangers, assuring the maximum safety.

### Technical data

- Dimensions: 630x300x95 mm
- Pack dimensions: 485x375x185 mm
- Machine weight: 7,2 kg
- Pressure: min 6 bar, max 10 bar
- Power: 10 bar=500 kgf
- CE approved machine in compliance with 2006/42/CE (Machine Directive)

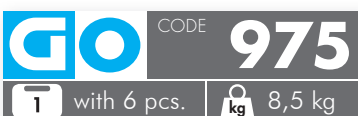
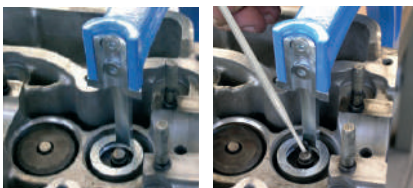

## + VALVE KEEPERS SET

- The valve keeper installation tool is especially designed for multi groove keepers.

### Components

- 1 x valve keeper tool 5 mm
- 1 x valve keeper tool 6 mm
- 1 x valve keeper tool 7 - 8 mm

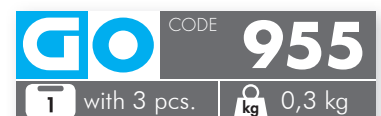



## MANUAL VALVE SPRING COMPRESSOR BENCH

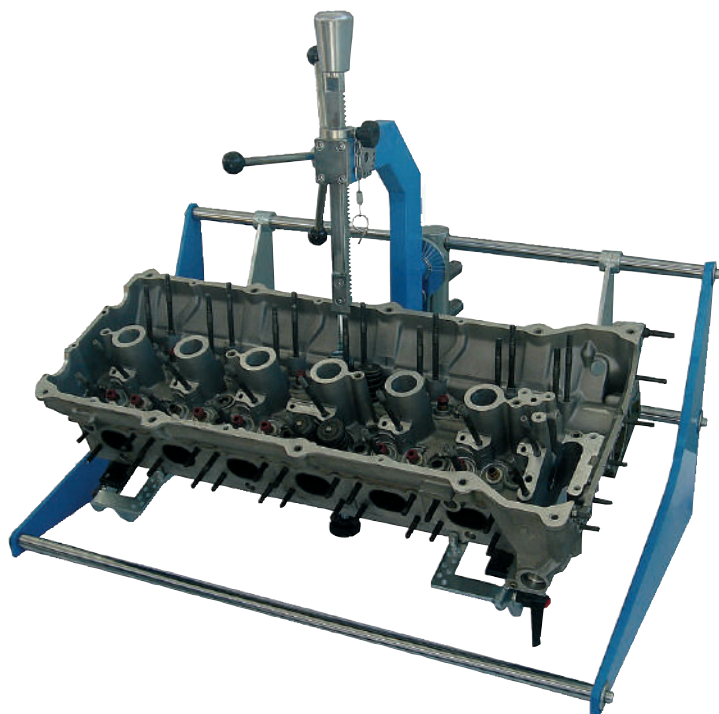

- The two head supports are implemented with non-scratch plastic material and are adjustable from 0 to 30°.
- There are two handles for locking when the right inclination is set.
- It is also possible to regulate the horizontal position of the head moving the pins to the opposite holes up and down.
- There is a long regulation also for the push rod in case of deep valve chambers.
- The frame can be rotated 30° on both sides.
- Moreover can be regulated also forward and backwards. In case of valves locked hard into the seat, hit on the slide hammer on the top with a plastic mallet. The bench is also provided with a travel limit device that guarantees the same stroke for each valve.
- Meanwhile the valve spring is compressed, the operator can block the position using the opposite pin. Consequently he can work on the valves having both hands free.



### Technical data

- Dimensions: 785x500x625 mm
- Stroke: 265 mm
- Cylinder head: 750 mm
- Length: min. 185 mm
- Inclination angle = 0° - 30°
- Total weight: 25.5 kg

### VALVE SPRING COMPRESSOR

1.	Ø19,8 mm	Estrattore
2.	Ø23,5 mm	Estrattore
a.	Ø24,5 mm	Boccola
b.	Ø25 mm	Boccola
c.	Ø27 mm	Boccola
d.	Ø29 mm	Boccola
e.	Ø32 mm	Boccola
3.	Ø34 mm	Estrattore
a.	Ø34 mm	Boccola
b.	Ø41 mm	Boccola
c.	Ø50 mm	Boccola

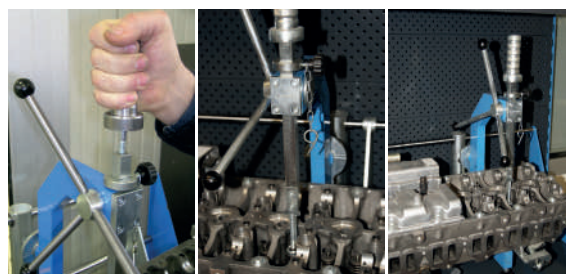

### Application

Cars and commercial vehicles

**GO** CODE **950**  
 with 1 pcs. 28,5 kg

## + VALVE KEEPERS SET

- The valve keeper installation tool is especially designed for multi groove keepers.



**GO** CODE **955**  
 with 3 pcs. 0,3 kg

### Components

- 1 x valve keeper tool 5 mm
- 1 x valve keeper tool 6 mm
- 1 x valve keeper tool 7 - 8 mm

## + MAGNETIC PICK-UP TOOL

- Handy tool in plastic material with magnet.
- Used to pick up loose parts easily, especially in narrow and difficult areas.



**GO** CODE **954**  
 with 1 pcs. 0,1 kg

### Technical data

- Length: 165 mm





## VALVE SPRING COMPRESSOR

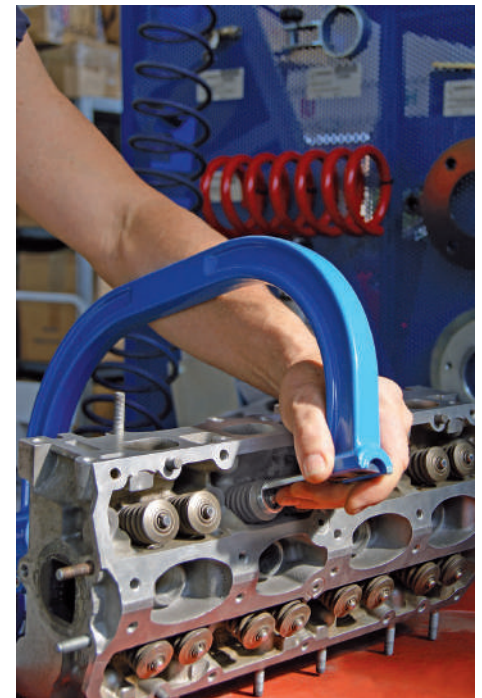
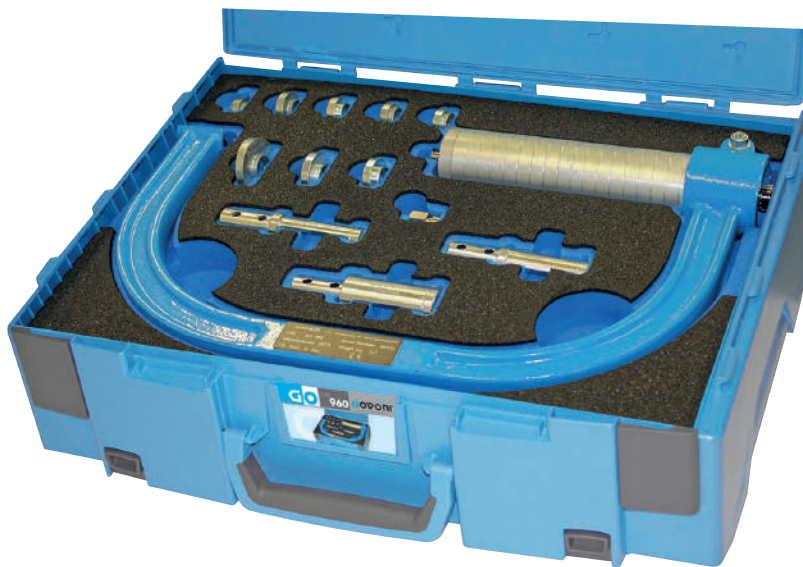

### Technical data

- CE approved machine in compliance with 2006/42/CE (Machine Directive)
- Case dimensions: 485x375x135 mm
- Machine weight: 5 kg
- Working pressure: min 6 bar., max 10 bar
- Power: 6 bar=75 kg, 10 bar=125 kgf

- Universal pneumatic tool for assembling and disassembling engine valves, suitable for all types of valves on petrol and diesel engines.
- Practical and easy to use, it permits time saving up to 60 - 70%, especially during valve assembly.
- Appositely made for engines with 4/5 valves for cylinder.

### Technical data

- CE approved machine in compliance with 2006/42/CE (Machine Directive)
- Case Dimensions: 485x375x135 mm
- Machine weight: 6 kg
- Working pressure: min 6 bar, max 10 bar
- Power: 6 bar=118 kg, 10 bar=196 kgf

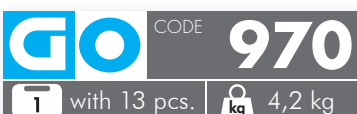

125 kgf

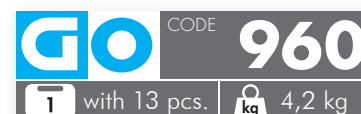

196 kgf

the toolmaker  
**GOVONI**<sup>®</sup>  
*...just blue, just perfect!*

**G KIT FOR THE BALANCE SHAFTS OF BMW, MINI**



**GO** CODE **713**  
T with 5 pcs.  
kg 2,3 kg

**BMW** Serie 1 (E81/82/87/88), Serie 3 (E46), Serie 3  
**MINI** Mini (R56/R57) One, Mini (R56/R57) Cooper, Clubman (R55) One, Clubman (R55) Cooper

**G TIMING TOOL SET SUITABLE FOR BMW**



**GO** CODE **744**  
T with 6 pcs.  
kg 2,7 kg

**BMW** Serie 1 (E81/82/87/88), Serie 3 (E46), Serie 3 (E90/91/92/93)



See all engine APPLICATIONS on the **THE TOOLFINDER™**

1.0	1.1	1.2	1.3	1.4	1.5	1.6	1.7	1.8	1.9
2.0	2.1	2.2	2.3	2.4	2.5	2.6	2.7	2.8	2.9
3.0	3.1	3.2	3.3	3.4	3.5	3.6	3.7	3.8	3.9
4.0	4.1	4.2	4.3	4.4	4.5	4.6	4.7	4.8	4.9



See all engine APPLICATIONS on the **THE TOOLFINDER™**

1.0	1.1	1.2	1.3	1.4	1.5	1.6	1.7	1.8	1.9
2.0	2.1	2.2	2.3	2.4	2.5	2.6	2.7	2.8	2.9
3.0	3.1	3.2	3.3	3.4	3.5	3.6	3.7	3.8	3.9
4.0	4.1	4.2	4.3	4.4	4.5	4.6	4.7	4.8	4.9

**G TIMING TOOL SET SUITABLE FOR BMW, MINI**



**GO** CODE **706**  
T with 6 pcs.  
kg 1,3 kg

**BMW** Serie 1, Serie 2 Coupe, Serie 3, Serie 3 Gran Turismo, Serie 4 Cabriolet, Serie 4 Coupe, Serie 4 Gran Coupe, Serie 5, Serie 5 Gran Turismo, Serie 6, Serie 6 Gran Coupe, Serie 7, X1, X3, X4, X5, X6  
**MINI** Clubman, Clubvan, Countryman, Coupe, Mini, Paceman, Roadster



See all engine APPLICATIONS on the **THE TOOLFINDER™**

1.0	1.1	1.2	1.3	1.4	1.5	1.6	1.7	1.8	1.9
2.0	2.1	2.2	2.3	2.4	2.5	2.6	2.7	2.8	2.9
3.0	3.1	3.2	3.3	3.4	3.5	3.6	3.7	3.8	3.9
4.0	4.1	4.2	4.3	4.4	4.5	4.6	4.7	4.8	4.9

**G TIMING TOOL SET SUITABLE FOR BMW**



**GO** CODE **737**  
T with 11 pcs.  
kg 4,3 kg

**BMW** Serie 3, Z3, Serie 5, Z4, X3, 7 Series, X5



See all engine APPLICATIONS on the **THE TOOLFINDER™**

1.0	1.1	1.2	1.3	1.4	1.5	1.6	1.7	1.8	1.9
2.0	2.1	2.2	2.3	2.4	2.5	2.6	2.7	2.8	2.9
3.0	3.1	3.2	3.3	3.4	3.5	3.6	3.7	3.8	3.9
4.0	4.1	4.2	4.3	4.4	4.5	4.6	4.7	4.8	4.9

**G** KIT FOR THE BALANCE SHAFTS OF **BMW**,  
>05/2012



**GO** CODE **723**  
1 with 2 pz.  
kg 3,5 kg

**BMW** Serie 1 (E81/82/87/88), Serie 1 (F20/21), Serie 2 Coupe (F22), Serie 3 (E90/91/92/93), Serie 3 (F30/31), Serie 3 Gran Turismo (F34), Serie 4 Cabriolet (F33), Serie 4 Coupe (F32), Serie 4 Gran Coupe (F36), Serie 5 (E60/61), Serie 5 (F10/11), Serie 5 Gran Turismo (F07), X1 (E84), X3 (E83), X3 (F25), X5 (F15)

**G** TIMING TOOL SET SUITABLE FOR **MINI**



**GO** CODE **855**  
1 with 9 pcs.  
kg 2,5 kg

**MINI** Cooper, Cooper S, Cooper S.J.C.W., One



See all engine APPLICATIONS on the THE TOOLFINDER™

1.0	1.1	1.2	1.3	1.4	1.5	1.6	1.7	1.8	1.9
2.0	2.1	2.2	2.3	2.4	2.5	2.6	2.7	2.8	2.9
3.0	3.1	3.2	3.3	3.4	3.5	3.6	3.7	3.8	3.9
4.0	4.1	4.2	4.3	4.4	4.5	4.6	4.7	4.8	4.9



See all engine APPLICATIONS on the THE TOOLFINDER™

1.0	1.1	1.2	1.3	1.4	1.5	1.6	1.7	1.8	1.9
2.0	2.1	2.2	2.3	2.4	2.5	2.6	2.7	2.8	2.9
3.0	3.1	3.2	3.3	3.4	3.5	3.6	3.7	3.8	3.9
4.0	4.1	4.2	4.3	4.4	4.5	4.6	4.7	4.8	4.9

**G** TIMING TOOL SET SUITABLE FOR **BMW**



**GO** CODE **769**  
1 with 7 pcs.  
kg 2,3 kg

**BMW** Serie 1, Serie 3, X3, Z4

**G** TIMING TOOL SET SUITABLE FOR **MINI**



**GO** CODE **701**  
1 with 10 pcs.  
kg 2,3 kg

**MINI** Mini (R56/57) One, Mini (R56/57) One/First, Mini (R56/57) Cooper, Mini (R56/57) Cooper S



See all engine APPLICATIONS on the THE TOOLFINDER™

1.0	1.1	1.2	1.3	1.4	1.5	1.6	1.7	1.8	1.9
2.0	2.1	2.2	2.3	2.4	2.5	2.6	2.7	2.8	2.9
3.0	3.1	3.2	3.3	3.4	3.5	3.6	3.7	3.8	3.9
4.0	4.1	4.2	4.3	4.4	4.5	4.6	4.7	4.8	4.9



See all engine APPLICATIONS on the THE TOOLFINDER™

1.0	1.1	1.2	1.3	1.4	1.5	1.6	1.7	1.8	1.9
2.0	2.1	2.2	2.3	2.4	2.5	2.6	2.7	2.8	2.9
3.0	3.1	3.2	3.3	3.4	3.5	3.6	3.7	3.8	3.9
4.0	4.1	4.2	4.3	4.4	4.5	4.6	4.7	4.8	4.9



**G** LOCKING TOOL SUITABLE FOR **BMW**,  
<04/2013



**GO** CODE **792**  
with 1 pcs.  
0,4 kg

**BMW** Serie 1, Serie 2 Coupe, Serie 3, Serie 3 Gran Turismo, Serie 4 Cabriolet, Serie 4 Coupe, Serie 4 Gran Coupe, Serie 5, Serie 5 Gran Turismo, Serie 6, Serie 6 Gran Coupe, Serie 7, X1, X3, X4, X5, X6

**G** TIMING TOOL SET SUITABLE FOR **MINI**



**GO** CODE **793**  
with 10 pcs.  
0,3 kg

**MINI** Clubman, Mini W16 D16 (9HZ)

See all engine APPLICATIONS on the **THE TOOL FINDER™**

1.0	1.1	1.2	1.3	1.4	1.5	1.6	1.7	1.8	1.9
2.0	2.1	2.2	2.3	2.4	2.5	2.6	2.7	2.8	2.9
3.0	3.1	3.2	3.3	3.4	3.5	3.6	3.7	3.8	3.9
4.0	4.1	4.2	4.3	4.4	4.5	4.6	4.7	4.8	4.9

See all engine APPLICATIONS on the **THE TOOL FINDER™**

1.0	1.1	1.2	1.3	1.4	1.5	1.6	1.7	1.8	1.9
2.0	2.1	2.2	2.3	2.4	2.5	2.6	2.7	2.8	2.9
3.0	3.1	3.2	3.3	3.4	3.5	3.6	3.7	3.8	3.9
4.0	4.1	4.2	4.3	4.4	4.5	4.6	4.7	4.8	4.9

**G** TIMING TOOL SET SUITABLE FOR **BMW**



**GO** CODE **795**  
with 10 pcs.  
0,4 kg

**BMW** Serie 1, Serie 2 Coupe, Serie 3, Serie 3 Gran Turismo, Serie 4 Cabriolet, Serie 4 Coupe, Serie 4 Gran Coupe, Serie 5, Serie 5 Gran Turismo, Serie 6, Serie 6 Gran Coupe, Serie 7, X1, X3, X4, X5, X6

**G** TIMING TOOL SET SUITABLE FOR **BMW**



**GO** CODE **731**  
with 11 pcs.  
2,2 kg

**BMW** Serie 1, Serie 2 Cabriolet, Serie 2 Coupe, Serie 3, Serie 3 Gran Turismo, Serie 4 Cabriolet, Serie 4 Coupe, Serie 4 Gran Coupe, Serie 5, X1, X3, X4, Z4

See all engine APPLICATIONS on the **THE TOOL FINDER™**

1.0	1.1	1.2	1.3	1.4	1.5	1.6	1.7	1.8	1.9
2.0	2.1	2.2	2.3	2.4	2.5	2.6	2.7	2.8	2.9
3.0	3.1	3.2	3.3	3.4	3.5	3.6	3.7	3.8	3.9
4.0	4.1	4.2	4.3	4.4	4.5	4.6	4.7	4.8	4.9

See all engine APPLICATIONS on the **THE TOOL FINDER™**

1.0	1.1	1.2	1.3	1.4	1.5	1.6	1.7	1.8	1.9
2.0	2.1	2.2	2.3	2.4	2.5	2.6	2.7	2.8	2.9
3.0	3.1	3.2	3.3	3.4	3.5	3.6	3.7	3.8	3.9
4.0	4.1	4.2	4.3	4.4	4.5	4.6	4.7	4.8	4.9

**G** TIMING TOOL SET SUITABLE FOR BMW, LAND ROVER, MG, ROVER



**GO** CODE **742**  
1 with 8 pcs.  
kg 1,2 kg

- BMW** Serie 3, Serie 5, Serie 1, X3, 7 Series, X5, X6
- LAND ROVER** Freelander, Range Rover
- MG** ZT/ZFT
- ROVER** 75



See all engine APPLICATIONS on the **THE TOOLFINDER™**

1.0	1.1	1.2	1.3	1.4	1.5	1.6	1.7	1.8	1.9
2.0	2.1	2.2	2.3	2.4	2.5	2.6	2.7	2.8	2.9
3.0	3.1	3.2	3.3	3.4	3.5	3.6	3.7	3.8	3.9
4.0	4.1	4.2	4.3	4.4	4.5	4.6	4.7	4.8	4.9

**G** TIMING TOOL SET SUITABLE FOR BMW



**GO** CODE **743**  
1 with 2 pcs.  
kg 0,2 kg

- BMW** Serie 1, Serie 3, Serie 5, Serie 7, X3, X5, X6



See all engine APPLICATIONS on the **THE TOOLFINDER™**

1.0	1.1	1.2	1.3	1.4	1.5	1.6	1.7	1.8	1.9
2.0	2.1	2.2	2.3	2.4	2.5	2.6	2.7	2.8	2.9
3.0	3.1	3.2	3.3	3.4	3.5	3.6	3.7	3.8	3.9
4.0	4.1	4.2	4.3	4.4	4.5	4.6	4.7	4.8	4.9

**G** TIMING PLATE SUITABLE FOR BMW



**GO** CODE **747**  
1 with 1 pcs.  
kg 1,1 kg

- BMW** Serie 3, Serie 5, Z3, Z4, X3, 7 Series, X5



See all engine APPLICATIONS on the **THE TOOLFINDER™**

1.0	1.1	1.2	1.3	1.4	1.5	1.6	1.7	1.8	1.9
2.0	2.1	2.2	2.3	2.4	2.5	2.6	2.7	2.8	2.9
3.0	3.1	3.2	3.3	3.4	3.5	3.6	3.7	3.8	3.9
4.0	4.1	4.2	4.3	4.4	4.5	4.6	4.7	4.8	4.9

**G** TIMING TOOL SET SUITABLE FOR BMW



**GO** CODE **710**  
1 with 4 pcs.  
kg 2 kg

- BMW** Serie 5, Serie 6, Serie 7, X5



See all engine APPLICATIONS on the **THE TOOLFINDER™**

1.0	1.1	1.2	1.3	1.4	1.5	1.6	1.7	1.8	1.9
2.0	2.1	2.2	2.3	2.4	2.5	2.6	2.7	2.8	2.9
3.0	3.1	3.2	3.3	3.4	3.5	3.6	3.7	3.8	3.9
4.0	4.1	4.2	4.3	4.4	4.5	4.6	4.7	4.8	6.0

**G** TIMING TOOL SET SUITABLE FOR **BMW**



**GO** CODE **724**  
T with 7 pcs.  
kg 4 kg

**BMW** Serie 1: 116i, 118i, 120i (E81/82/87/88), Serie 3: 316i, 318i, 320i (E90/91/92/93), Serie 5: 520i (E60/61)

**G** TIMING TOOL SET SUITABLE FOR **BMW**



**GO** CODE **861**  
T with 10 pcs.  
kg 6,6 kg

**BMW** Serie 1, Serie 3, Serie 5, Serie 6, Serie 7, X1, X3, X5, X6, Z4

See all engine APPLICATIONS on the THE**TOOL**FINDER™

1.0	1.1	1.2	1.3	1.4	1.5	1.6	1.7	1.8	1.9
2.0	2.1	2.2	2.3	2.4	2.5	2.6	2.7	2.8	2.9
3.0	3.1	3.2	3.3	3.4	3.5	3.6	3.7	3.8	3.9
4.0	4.1	4.2	4.3	4.4	4.5	4.6	4.7	4.8	4.9

See all engine APPLICATIONS on the THE**TOOL**FINDER™

1.0	1.1	1.2	1.3	1.4	1.5	1.6	1.7	1.8	1.9
2.0	2.1	2.2	2.3	2.4	2.5	2.6	2.7	2.8	2.9
3.0	3.1	3.2	3.3	3.4	3.5	3.6	3.7	3.8	3.9
4.0	4.1	4.2	4.3	4.4	4.5	4.6	4.7	4.8	4.9

**G** TIMING TOOL SET SUITABLE FOR **BMW, MINI**



**GO** CODE **865**  
T with 17 pcs.  
kg 6,2 kg

**BMW** Serie 1, Serie 2 Active Tourer, Serie 2 Cabriolet, Serie 2 Coupe, Serie 2 Gran Tourer, Serie 3, Serie 4 Coupe, Serie 4 Gran Coupe, i8, X1, X2, X3

See all engine APPLICATIONS on the THE**TOOL**FINDER™

1.0	1.1	1.2	1.3	1.4	1.5	1.6	1.7	1.8	1.9
2.0	2.1	2.2	2.3	2.4	2.5	2.6	2.7	2.8	2.9
3.0	3.1	3.2	3.3	3.4	3.5	3.6	3.7	3.8	3.9
4.0	4.1	4.2	4.3	4.4	4.5	4.6	4.7	4.8	4.9

**G** TIMING TOOL SET SUITABLE FOR **BMW**



**GO** CODE **867**  
T with 1 pcs.  
kg 2,12 kg

**BMW** Serie 1, Serie 2, Serie 3, Serie 4, Serie 5, X1, X3, X4, X5 (2013-)

**MINI** Clubman, Clubvan, Convertible, Mini Hatch, Paceman (2013-)

See all engine APPLICATIONS on the THE**TOOL**FINDER™

1.0	1.1	1.2	1.3	1.4	1.5	1.6	1.7	1.8	1.9
2.0	2.1	2.2	2.3	2.4	2.5	2.6	2.7	2.8	2.9
3.0	3.1	3.2	3.3	3.4	3.5	3.6	3.7	3.8	3.9
4.0	4.1	4.2	4.3	4.4	4.5	4.6	4.7	4.8	4.9

**G** TIMING TOOL SET SUITABLE FOR **BMW, MINI**



**GO** CODE **870**  
T with 7 pcs.  
kg 0,76 kg

- BMW** Serie 1, Serie 2 Active Tourer, Serie 2 Cabriolet, 2 Series Coupe, Serie 2 Gran Tourer, Serie 3, Serie 3 Gran Turismo, Serie 4 Cabriolet, Serie 4 Coupe, Serie 4 Gran Coupe, Serie 5, X1, X3, X4, X5
- MINI** Clubman, Convertible, Mini Hatch



See all engine APPLICATIONS on the **THE TOOLFINDER™**

1.0	1.1	1.2	1.3	1.4	<b>1.5</b>	1.6	1.7	1.8	1.9
<b>2.0</b>	2.1	2.2	2.3	2.4	2.5	2.6	2.7	2.8	2.9
3.0	3.1	3.2	3.3	3.4	3.5	3.6	3.7	3.8	3.9
4.0	4.1	4.2	4.3	4.4	4.5	4.6	4.7	4.8	4.9

**G** LOCKING TOOL SUITABLE FOR **BMW, MINI**



**GO** CODE **777**  
T with 1 pcs.  
kg 0,5 kg

- BMW** 1 Series, 2 Series Coupe, 3 Series, 3 Series Gran Turismo, 4 Series Cabriolet, 4 Series Coupe, 4 Series Gran Coupe, 5 Series, 5 Series Gran Turismo, X1, X3
- MINI** Clubman, Clubvan, Countryman, Coupe, Mini, Paceman, Roadster



See all engine APPLICATIONS on the **THE TOOLFINDER™**

1.0	1.1	1.2	1.3	1.4	1.5	<b>1.6</b>	1.7	1.8	1.9
<b>2.0</b>	2.1	2.2	2.3	2.4	2.5	2.6	2.7	2.8	2.9
3.0	3.1	3.2	3.3	3.4	3.5	3.6	3.7	3.8	3.9
4.0	4.1	4.2	4.3	4.4	4.5	4.6	4.7	4.8	4.9

**G** TIMING TOOL SET SUITABLE FOR **FCA**



**GO** CODE **786**  
T with 8 pcs.  
kg 1,4 kg

- ALFA** Mito, Giulietta
- FIAT** 500/500C, Panda/Panda Classic, Punto, Brava, Bravo, Marea, Marea Weekend/Marengo, Idea, Tipo Palio Weekend, Punto/Punto Classic, Stilo, Ritmo, Doblo, Doblo Cargo, Grande Punto, Linea, 500L, 500X, Tipo
- LANCIA** Ypsilon, Musa, Delta



See all engine APPLICATIONS on the **THE TOOLFINDER™**

1.0	1.1	<b>1.2</b>	1.3	<b>1.4</b>	1.5	1.6	1.7	1.8	1.9
2.0	2.1	2.2	2.3	2.4	2.5	2.6	2.7	2.8	2.9
3.0	3.1	3.2	3.3	3.4	3.5	3.6	3.7	3.8	3.9
4.0	4.1	4.2	4.3	4.4	4.5	4.6	4.7	4.8	4.9

**G** BELT TENSIONER SUITABLE FOR **FIAT**



**GO** CODE **859**  
T with 1 pcs.  
kg 0,1 kg

Diameter: Ø2.5 mm



**G** BELT TENSIONER SUITABLE FOR **FIAT**

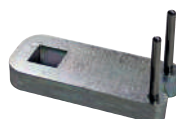

**GO** CODE **756**  
T with 1 pcs.  
kg 0,1 kg

Diameter: Ø2 mm





**G** TIMING TOOL SET SUITABLE FOR **FCA**

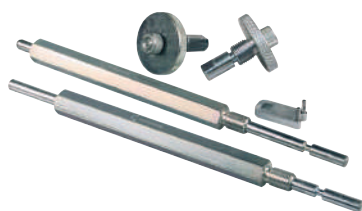

**GO** CODE **735**  
T with 5 pcs.  
kg 1,2 kg

**FIAT** Punto, Brava, Bravo, Marea, Marea Weekend/Marengo, Idea, Palio Weekend, Punto/Punto Classic, Stilo, 500L, Doblo, Doblo

**LANCIA** Ypsilon, Musa

**G** TIMING TOOL SET SUITABLE FOR **ALFA**



**GO** CODE **736**  
T with 2 pcs.  
kg 0,3 kg

**ALFA** 147

See all engine APPLICATIONS on the **THE TOOL FINDER™**

1.0	1.1	1.2	1.3	1.4	1.5	1.6	1.7	1.8	1.9
2.0	2.1	2.2	2.3	2.4	2.5	2.6	2.7	2.8	2.9
3.0	3.1	3.2	3.3	3.4	3.5	3.6	3.7	3.8	3.9
4.0	4.1	4.2	4.3	4.4	4.5	4.6	4.7	4.8	4.9

See all engine APPLICATIONS on the **THE TOOL FINDER™**

1.0	1.1	1.2	1.3	1.4	1.5	1.6	1.7	1.8	1.9
2.0	2.1	2.2	2.3	2.4	2.5	2.6	2.7	2.8	2.9
3.0	3.1	3.2	3.3	3.4	3.5	3.6	3.7	3.8	3.9
4.0	4.1	4.2	4.3	4.4	4.5	4.6	4.7	4.8	4.9

**G** TIMING TOOL SET SUITABLE FOR **ALFA**



**GO** CODE **754**  
T with 6 pcs.  
kg 0,6 kg

**ALFA** GTV, Spider, 156, 145, 146, 147, 166, 155

**G** TIMING TOOL SET SUITABLE FOR **ALFA**



**GO** CODE **760**  
T with 4 pcs.  
kg 0,4 kg

**ALFA** 156, GT, GTV, Spider

See all engine APPLICATIONS on the **THE TOOL FINDER™**

1.0	1.1	1.2	1.3	1.4	1.5	1.6	1.7	1.8	1.9
2.0	2.1	2.2	2.3	2.4	2.5	2.6	2.7	2.8	2.9
3.0	3.1	3.2	3.3	3.4	3.5	3.6	3.7	3.8	3.9
4.0	4.1	4.2	4.3	4.4	4.5	4.6	4.7	4.8	4.9

See all engine APPLICATIONS on the **THE TOOL FINDER™**

1.0	1.1	1.2	1.3	1.4	1.5	1.6	1.7	1.8	1.9
2.0	2.1	2.2	2.3	2.4	2.5	2.6	2.7	2.8	2.9
3.0	3.1	3.2	3.3	3.4	3.5	3.6	3.7	3.8	3.9
4.0	4.1	4.2	4.3	4.4	4.5	4.6	4.7	4.8	4.9

**G** TIMING TOOL SET SUITABLE FOR **ALFA**



**GO** CODE **875**  
 with 4 pcs.  
 0,5 kg

**ALFA** Giulia, Stelvio

**G** TIMING TOOL SET SUITABLE FOR **FCA, PSA, FORD**



**GO** CODE **758**  
 with 16 pcs.  
 5,6 kg

**FIAT** Ducato

**IVECO** Daily, Massif, Campagnola

**PEUGEOT** Boxer III

**CITROËN** Relay/Jumper III

**FORD** Transit



See all engine APPLICATIONS on the **THE TOOLFINDER™**

1.0	1.1	1.2	1.3	1.4	1.5	1.6	1.7	1.8	1.9
2.0	2.1	2.2	2.3	2.4	2.5	2.6	2.7	2.8	2.9
3.0	3.1	3.2	3.3	3.4	3.5	3.6	3.7	3.8	3.9
4.0	4.1	4.2	4.3	4.4	4.5	4.6	4.7	4.8	4.9



See all engine APPLICATIONS on the **THE TOOLFINDER™**

1.0	1.1	1.2	1.3	1.4	1.5	1.6	1.7	1.8	1.9
2.0	2.1	2.2	2.3	2.4	2.5	2.6	2.7	2.8	2.9
3.0	3.1	3.2	3.3	3.4	3.5	3.6	3.7	3.8	3.9
4.0	4.1	4.2	4.3	4.4	4.5	4.6	4.7	4.8	4.9

**G** TIMING TOOL SET SUITABLE FOR **FCA**



**GO** CODE **752**  
 with 9 pcs.  
 1,7 kg

**ALFA** Mito

**FIAT** 500/500C, Grande Punto, Panda, Panda/Panda Classic, Punto, Punto Evo, Palio, Palio Weekend, Punto/Punto Classic, Strada Pick-up, Doblo, Doblo Cargo, Fiorino, Idea, Linea, Qubo

**LANCIA** Ypsilon, Musa



See all engine APPLICATIONS on the **THE TOOLFINDER™**

1.0	1.1	1.2	1.3	1.4	1.5	1.6	1.7	1.8	1.9
2.0	2.1	2.2	2.3	2.4	2.5	2.6	2.7	2.8	2.9
3.0	3.1	3.2	3.3	3.4	3.5	3.6	3.7	3.8	3.9
4.0	4.1	4.2	4.3	4.4	4.5	4.6	4.7	4.8	4.9

**G** TIMING TOOL SET SUITABLE FOR **FCA**



**GO** CODE **738**  
 with 5 pcs.  
 2 kg

**FIAT** Palio Weekend, Brava, Bravo, Marea, Marea Weekend/Marengo, Multipla, Doblo, Doblo Cargo, Stilo

**LANCIA** Dedra, Delta, Lybra



See all engine APPLICATIONS on the **THE TOOLFINDER™**

1.0	1.1	1.2	1.3	1.4	1.5	1.6	1.7	1.8	1.9
2.0	2.1	2.2	2.3	2.4	2.5	2.6	2.7	2.8	2.9
3.0	3.1	3.2	3.3	3.4	3.5	3.6	3.7	3.8	3.9
4.0	4.1	4.2	4.3	4.4	4.5	4.6	4.7	4.8	4.9

**G** TIMING TOOL SET SUITABLE FOR FCA



**GO** CODE **772**  
with 7 pcs.  
1 kg

- ALFA** Giulietta, Mito
- FIAT** Punto, Punto Evo, 500X
- JEEP** Compass

**G** TIMING TOOL SET SUITABLE FOR FCA



**GO** CODE **780**  
with 6 pcs.  
3 kg

- ALFA** Mito
- FIAT** 500/500C, Panda, Punto, 500L/500L Living/500L MPW
- LANCIA** Ypsilon



See all engine APPLICATIONS on the **THE TOOL FINDER™**

1.0	1.1	1.2	1.3	1.4	1.5	1.6	1.7	1.8	1.9
2.0	2.1	2.2	2.3	2.4	2.5	2.6	2.7	2.8	2.9
3.0	3.1	3.2	3.3	3.4	3.5	3.6	3.7	3.8	3.9
4.0	4.1	4.2	4.3	4.4	4.5	4.6	4.7	4.8	4.9



See all engine APPLICATIONS on the **THE TOOL FINDER™**

0.9	1.1	1.2	1.3	1.4	1.5	1.6	1.7	1.8	1.9
2.0	2.1	2.2	2.3	2.4	2.5	2.6	2.7	2.8	2.9
3.0	3.1	3.2	3.3	3.4	3.5	3.6	3.7	3.8	3.9
4.0	4.1	4.2	4.3	4.4	4.5	4.6	4.7	4.8	4.9

**G** TIMING TOOL SET SUITABLE FOR FCA



**GO** CODE **703**  
with 10 pcs.  
2,2 kg

- ALFA** 147, 156, Mito, 145, 146, 166, Crosswagon, GT, 159, Brera, Spider, Giulietta
- FIAT** 500/500C, Panda/Panda Classic, Brava, Bravo, Marea, Marea Weekend/Marengo, Multipla, Doblo, Doblo Cargo, Palio Weekend, Punto/Punto Classic, Strada Pick-up, Idea, Stilo, Ritmo, Doblo Work Up, Linea, Fiorino, Grande Punto, Punto Evo, Qubo, Panda, Punto, 500L, Croma, Freemont, Sedici, Tipo, 500X
- LANCIA** Musa, Ypsilon, Delta, Lybra, Kappa, Thesis
- JEEP** Compass, Renegade



See all engine APPLICATIONS on the **THE TOOL FINDER™**

1.0	1.1	1.2	1.3	1.4	1.5	1.6	1.7	1.8	1.9
2.0	2.1	2.2	2.3	2.4	2.5	2.6	2.7	2.8	2.9
3.0	3.1	3.2	3.3	3.4	3.5	3.6	3.7	3.8	3.9
4.0	4.1	4.2	4.3	4.4	4.5	4.6	4.7	4.8	4.9

**G** TIMING TOOL SET SUITABLE FOR FCA



**GO** CODE **702**  
with 6 pcs.  
1,5 kg

- ALFA** Mito
- FIAT** 500/500C, Panda/Panda Classic, Doblo, Doblo Cargo, Idea, Punto/Punto Classic, Fiorino, Grande Punto, Punto Evo, Qubo, Doblo Work Up, Linea, Panda, Punto, Strada Pick-up, 500X
- LANCIA** Musa, Ypsilon



See all engine APPLICATIONS on the **THE TOOL FINDER™**

1.0	1.1	1.2	1.3	1.4	1.5	1.6	1.7	1.8	1.9
2.0	2.1	2.2	2.3	2.4	2.5	2.6	2.7	2.8	2.9
3.0	3.1	3.2	3.3	3.4	3.5	3.6	3.7	3.8	3.9
4.0	4.1	4.2	4.3	4.4	4.5	4.6	4.7	4.8	4.9

**G** TIMING PLATE SUITABLE FOR FIAT



**GO** CODE **826**  
with 1 pcs.  
0,5 kg

**FIAT** Panda, Punto, Palio, Palio Weekend, Strada Pick-up

**G** TIMING TOOL SET SUITABLE FOR FCA



**GO** CODE **876**  
with 6 pcs.  
1,2 kg

**FIAT** 500X  
**JEEP** Renegade



See all engine APPLICATIONS on the **THE TOOLFINDER™**

1.0	1.1	1.2	1.3	1.4	1.5	1.6	1.7	1.8	1.9
2.0	2.1	2.2	2.3	2.4	2.5	2.6	2.7	2.8	2.9
3.0	3.1	3.2	3.3	3.4	3.5	3.6	3.7	3.8	3.9
4.0	4.1	4.2	4.3	4.4	4.5	4.6	4.7	4.8	4.9



See all engine APPLICATIONS on the **THE TOOLFINDER™**

1.0	1.1	1.2	1.3	1.4	1.5	1.6	1.7	1.8	1.9
2.0	2.1	2.2	2.3	2.4	2.5	2.6	2.7	2.8	2.9
3.0	3.1	3.2	3.3	3.4	3.5	3.6	3.7	3.8	3.9
4.0	4.1	4.2	4.3	4.4	4.5	4.6	4.7	4.8	4.9

**G** TIMING TOOL SET SUITABLE FOR FCA



**GO** CODE **726**  
with 6 pcs.  
1 kg

**ALFA** 147, 156, 159, 166, Brera, Crosswagon, Giulietta, GT, MiTo, Spider  
**FIAT** 500L/500L Living/500L MPW, 500X, Brava, Bravo, Croma, Doblo, Doblo Cargo, Doblo Work Up, Ducato, Freemont, Grande Punto, Idea, Linea, Marea, Marea Weekend/Marengo, Multipla, Palio Weekend, Punto, Punto Evo, Punto/Punto Classic, Ritmo, Sedici, Stilo, Strada Pick-up, Tipo  
**LANCIA** Delta, Kappa, Lybra, Musa, Thesis



See all engine APPLICATIONS on the **THE TOOLFINDER™**

1.0	1.1	1.2	1.3	1.4	1.5	1.6	1.7	1.8	1.9
2.0	2.1	2.2	2.3	2.4	2.5	2.6	2.7	2.8	2.9
3.0	3.1	3.2	3.3	3.4	3.5	3.6	3.7	3.8	3.9
4.0	4.1	4.2	4.3	4.4	4.5	4.6	4.7	4.8	4.9

**G** FLYWHEEL LOCKING TOOL SUITABLE FOR FCA



**GO** CODE **812**  
with 1 pcs.  
0,2 kg

**ALFA** 147, 156, 145, 146, Giulietta, Mito  
**FIAT** Brava, Bravo, Marea, Marea Weekend/Marengo, Multipla, Doblo, Doblo Cargo, Palio Weekend, Punto/Punto Classic, Strada Pick-up, Idea, Stilo, Doblo Work Up, Linea, Grande Punto, Punto, Punto Evo, 500L, Tipo  
**LANCIA** Musa, Delta, Lybra



See all engine APPLICATIONS on the **THE TOOLFINDER™**

1.0	1.1	1.2	1.3	1.4	1.5	1.6	1.7	1.8	1.9
2.0	2.1	2.2	2.3	2.4	2.5	2.6	2.7	2.8	2.9
3.0	3.1	3.2	3.3	3.4	3.5	3.6	3.7	3.8	3.9
4.0	4.1	4.2	4.3	4.4	4.5	4.6	4.7	4.8	4.9



**G** TIMING TOOL SET SUITABLE FOR  
**CHRYSLER, JEEP**



**GO** CODE **722**  
T with 7 pcs.  
kg 0,6 kg

**CHRYSLER** Grand Voyager, Voyager  
**JEEP** Cherokee  
**LDV** Maxus

**G** CAMSHAFT LOCKING TOOL  
SUITABLE FOR **CHRYSLER**



**GO** CODE **764**  
T with 1 pcs.  
kg 1 kg

**CHRYSLER** Voyager, Grand Voyager, Cherokee

See all engine APPLICATIONS on the THE**TOOL**FINDER™

1.0	1.1	1.2	1.3	1.4	1.5	1.6	1.7	1.8	1.9
2.0	2.1	2.2	2.3	2.4	2.5	2.6	2.7	2.8	2.9
3.0	3.1	3.2	3.3	3.4	3.5	3.6	3.7	3.8	3.9
4.0	4.1	4.2	4.3	4.4	4.5	4.6	4.7	4.8	4.9

See all engine APPLICATIONS on the THE**TOOL**FINDER™

1.0	1.1	1.2	1.3	1.4	1.5	1.6	1.7	1.8	1.9
2.0	2.1	2.2	2.3	2.4	2.5	2.6	2.7	2.8	2.9
3.0	3.1	3.2	3.3	3.4	3.5	3.6	3.7	3.8	3.9
4.0	4.1	4.2	4.3	4.4	4.5	4.6	4.7	4.8	4.9

**G** TIMING TOOL SET SUITABLE FOR **FCA**



**GO** CODE **860**  
T with 9 pcs.  
kg 3,5 kg

**ALFA ROMEO** 159, 4C, Brera, Giulietta, Spider  
**LANCIA** Delta

See all engine APPLICATIONS on the THE**TOOL**FINDER™

1.0	1.1	1.2	1.3	1.4	1.5	1.6	1.7	1.8	1.9
2.0	2.1	2.2	2.3	2.4	2.5	2.6	2.7	2.8	2.9
3.0	3.1	3.2	3.3	3.4	3.5	3.6	3.7	3.8	3.9
4.0	4.1	4.2	4.3	4.4	4.5	4.6	4.7	4.8	4.9

**G** TIMING PLATE SUITABLE FOR **FCA**



**GO** CODE **872**  
T with 1 pcs.  
kg 0,4 kg

**FIAT** Chrysler Ypsilon, Fiat 500, Panda, Punto, Lancia Ypsilon  
**ALFA** Mito

See all engine APPLICATIONS on the THE**TOOL**FINDER™

0.9	1.1	1.2	1.3	1.4	1.5	1.6	1.7	1.8	1.9
2.0	2.1	2.2	2.3	2.4	2.5	2.6	2.7	2.8	2.9
3.0	3.1	3.2	3.3	3.4	3.5	3.6	3.7	3.8	3.9
4.0	4.1	4.2	4.3	4.4	4.5	4.6	4.7	4.8	4.9

**G** TIMING TOOL SET SUITABLE FOR **FIAT, IVECO**



**GO** CODE **741**  
T with 4 pcs.  
kg 0,8 kg

**FIAT** Ducato  
**IVECO** Daily

**G** VARIABLE CAMSHAFT TIMING TOOL SET **FORD**

**NEW**



**GO** CODE **771**  
T with 2 pcs.  
kg 0,88 kg

**FORD** C-Max (2017-), Focus (20218), Focus (2018-), Transit Connect (2017-), Puma (2019-), Fiesta (2017-)



See all engine APPLICATIONS on the THE<sup>T</sup>OOLFINDER™

1.0	1.1	1.2	1.3	1.4	1.5	1.6	1.7	1.8	1.9
2.0	2.1	2.2	2.3	2.4	2.5	2.6	2.7	2.8	2.9
3.0	3.1	3.2	3.3	3.4	3.5	3.6	3.7	3.8	3.9
4.0	4.1	4.2	4.3	4.4	4.5	4.6	4.7	4.8	4.9



See all engine APPLICATIONS on the THE<sup>T</sup>OOLFINDER™

1.0	1.1	1.2	1.3	1.4	1.5	1.6	1.7	1.8	1.9
2.0	2.1	2.2	2.3	2.4	2.5	2.6	2.7	2.8	2.9
3.0	3.1	3.2	3.3	3.4	3.5	3.6	3.7	3.8	3.9
4.0	4.1	4.2	4.3	4.4	4.5	4.6	4.7	4.8	4.9

**G** TIMING TOOL SET SUITABLE FOR **FORD**

**NEW**



**GO** CODE **773**  
T with 21 pcs.  
kg 1,4 kg

**FORD** 2012 -



See all engine APPLICATIONS on the THE<sup>T</sup>OOLFINDER™

1.0	1.1	1.2	1.3	1.4	1.5	1.6	1.7	1.8	1.9
2.0	2.1	2.2	2.3	2.4	2.5	2.6	2.7	2.8	2.9
3.0	3.1	3.2	3.3	3.4	3.5	3.6	3.7	3.8	3.9
4.0	4.1	4.2	4.3	4.4	4.5	4.6	4.7	4.8	4.9

**+** TORQUE MULTIPLIER

- Ideal when high torques are required for connections to be tightened and disassembled.

**Technical data**

- Input torque 300 Nm with 1/2' internal connection
- Output torque 1,500 Nm with 3/4' external connection



**GO** CODE **390**  
T with 3 pcs. kg 3 Kg

**G** TIMING TOOL SET SUITABLE FOR **FORD, MAZDA**



**GO** CODE **746**  
 with 6 pcs.  
 1,2 kg

**FORD** Focus, Fiesta, Fusion, Puma, C-MAX, Focus C-MAX, Escort, Orion, Mondeo, Maverick  
**MAZDA** 121, 2, Tribute

**G** TIMING TOOL SET SUITABLE FOR **FORD**



**GO** CODE **749**  
 with 11 pcs.  
 1,7 kg

**FORD** Transit, Mondeo, Focus

See all engine APPLICATIONS on the THE**TOOL**FINDER™

1.0	1.1	1.2	1.3	1.4	1.5	1.6	1.7	1.8	1.9
2.0	2.1	2.2	2.3	2.4	2.5	2.6	2.7	2.8	2.9
3.0	3.1	3.2	3.3	3.4	3.5	3.6	3.7	3.8	3.9
4.0	4.1	4.2	4.3	4.4	4.5	4.6	4.7	4.8	4.9

See all engine APPLICATIONS on the THE**TOOL**FINDER™

1.0	1.1	1.2	1.3	1.4	1.5	1.6	1.7	1.8	1.9
2.0	2.1	2.2	2.3	2.4	2.5	2.6	2.7	2.8	2.9
3.0	3.1	3.2	3.3	3.4	3.5	3.6	3.7	3.8	3.9
4.0	4.1	4.2	4.3	4.4	4.5	4.6	4.7	4.8	4.9

**G** TIMING TOOL SET SUITABLE FOR **FORD, MAZDA**



**GO** CODE **712**  
 with 16 pcs.  
 1,7 kg

**FORD** Fiesta, Fusion, Focus, Focus C-Max, C-Max, B-Max, S-Max, Galaxy, Mondeo, Ecosport  
**MAZDA** 2, 3

**G** TIMING TOOL SET SUITABLE FOR **FORD**

**UPGRADE**



**GO** CODE **794**  
 with 6 pcs.  
 3 kg

**FORD** B-Max, C-Max, EcoSport, Fiesta, Focus, Grand C-Max

See all engine APPLICATIONS on the THE**TOOL**FINDER™

1.0	1.1	1.2	1.3	1.4	1.5	1.6	1.7	1.8	1.9
2.0	2.1	2.2	2.3	2.4	2.5	2.6	2.7	2.8	2.9
3.0	3.1	3.2	3.3	3.4	3.5	3.6	3.7	3.8	3.9
4.0	4.1	4.2	4.3	4.4	4.5	4.6	4.7	4.8	4.9

See all engine APPLICATIONS on the THE**TOOL**FINDER™

1.0	1.1	1.2	1.3	1.4	1.5	1.6	1.7	1.8	1.9
2.0	2.1	2.2	2.3	2.4	2.5	2.6	2.7	2.8	2.9
3.0	3.1	3.2	3.3	3.4	3.5	3.6	3.7	3.8	3.9
4.0	4.1	4.2	4.3	4.4	4.5	4.6	4.7	4.8	4.9

**G** TIMING TOOL SET SUITABLE FOR  
**HYUNDAI, KIA, AdBlue<sup>®</sup>**



**NEW**

**GO** CODE **770**  
with 11 pcs.  
1,5 kg

**HYUNDAI** i30 (2019-), i40 (2018-), Kona (2018-), Tucson (2018-)  
**KIA** Ceed (2018-), Optima (2018-), ProCeed (2019-), Sportage (2018-), Stonic (2018-), XCeed (2019-)



See all engine APPLICATIONS on the **THE TOOLFINDER™**

1.0	1.1	1.2	1.3	1.4	1.5	1.6	1.7	1.8	1.9
2.0	2.1	2.2	2.3	2.4	2.5	2.6	2.7	2.8	2.9
3.0	3.1	3.2	3.3	3.4	3.5	3.6	3.7	3.8	3.9
4.0	4.1	4.2	4.3	4.4	4.5	4.6	4.7	4.8	4.9

**G** VARIABLE CAMSHAFT TIMING TOOL SET  
**FORD**



**GO** CODE **820**  
with 2 pcs.  
1,6 kg

**FORD** C-MAX, Focus, Grand C-MAX, EcoSport, Fiesta, Tourneo Connect, Transit Connect, B-MAX



See all engine APPLICATIONS on the **THE TOOLFINDER™**

1.0	1.1	1.2	1.3	1.4	1.5	1.6	1.7	1.8	1.9
2.0	2.1	2.2	2.3	2.4	2.5	2.6	2.7	2.8	2.9
3.0	3.1	3.2	3.3	3.4	3.5	3.6	3.7	3.8	3.9
4.0	4.1	4.2	4.3	4.4	4.5	4.6	4.7	4.8	4.9

**G** TIMING TOOL SET SUITABLE FOR **FORD**



**GO** CODE **729**  
with 6 pcs.  
1 kg

**FORD** Focus, Fiesta, Fusion, C-MAX, B-MAX, Grand Tourneo Connect, Kuga, Mondeo, Galaxy, Puma, EcoSport



See all engine APPLICATIONS on the **THE TOOLFINDER™**

1.0	1.1	1.2	1.3	1.4	1.5	1.6	1.7	1.8	1.9
2.0	2.1	2.2	2.3	2.4	2.5	2.6	2.7	2.8	2.9
3.0	3.1	3.2	3.3	3.4	3.5	3.6	3.7	3.8	3.9
4.0	4.1	4.2	4.3	4.4	4.5	4.6	4.7	4.8	4.9

**G** TIMING TOOL SET SUITABLE FOR **FORD, MAZDA**

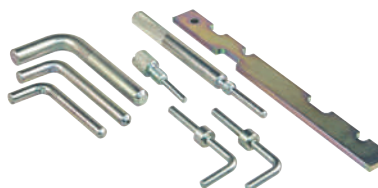

**GO** CODE **734**  
with 8 pcs.  
0,8 kg

**FORD** Fiesta, Fusion, Focus, C-MAX, Focus C-MAX, Escort, Orion, Mondeo

**MAZDA** 121, 2



See all engine APPLICATIONS on the **THE TOOLFINDER™**

1.0	1.1	1.2	1.3	1.4	1.5	1.6	1.7	1.8	1.9
2.0	2.1	2.2	2.3	2.4	2.5	2.6	2.7	2.8	2.9
3.0	3.1	3.2	3.3	3.4	3.5	3.6	3.7	3.8	3.9
4.0	4.1	4.2	4.3	4.4	4.5	4.6	4.7	4.8	4.9



**G** TIMING TOOL SET SUITABLE FOR **FORD**



**GO** CODE **761**  
 with 4 pcs.  
 0,6 kg

**FORD** Focus, Galaxy, Mondeo, S-Max



See all engine APPLICATIONS on the **THE TOOL FINDER™**

1.0	1.1	1.2	1.3	1.4	1.5	1.6	1.7	1.8	1.9
<b>2.0</b>	2.1	2.2	2.3	2.4	2.5	2.6	2.7	2.8	2.9
3.0	3.1	3.2	3.3	3.4	3.5	3.6	3.7	3.8	3.9
4.0	4.1	4.2	4.3	4.4	4.5	4.6	4.7	4.8	4.9

**G** TIMING TOOL SET SUITABLE FOR **FORD, MAZDA**



**GO** CODE **778**  
 with 19 pcs.  
 2,3 kg

**FORD** C-Max, Courier, Escort, Fiesta, Fiesta Econetic, Focus, Focus C-Max, Fusion, Mondeo

**MAZDA** 2, 3, 5



See all engine APPLICATIONS on the **THE TOOL FINDER™**

1.0	1.1	1.2	1.3	<b>1.4</b>	1.5	<b>1.6</b>	1.7	<b>1.8</b>	<b>1.9</b>
<b>2.0</b>	2.1	<b>2.2</b>	2.3	2.4	<b>2.5</b>	2.6	2.7	2.8	2.9
3.0	3.1	3.2	3.3	3.4	3.5	3.6	3.7	3.8	3.9
4.0	4.1	4.2	4.3	4.4	4.5	4.6	4.7	4.8	4.9

**G** TIMING TOOL SET SUITABLE FOR **FORD**



**GO** CODE **864**  
 with 13 pcs.  
 3,2 kg

**FORD** Focus, Focus Active, Galaxy, S-MAX, Tourneo Custom, Transit, Transit Custom



See all engine APPLICATIONS on the **THE TOOL FINDER™**

1.0	1.1	1.2	1.3	1.4	1.5	1.6	1.7	1.8	1.9
<b>2.0</b>	2.1	2.2	2.3	2.4	2.5	2.6	2.7	2.8	2.9
3.0	3.1	3.2	3.3	3.4	3.5	3.6	3.7	3.8	3.9
4.0	4.1	4.2	4.3	4.4	4.5	4.6	4.7	4.8	4.9

**G** TIMING TOOL SET SUITABLE FOR **FORD**



**GO** CODE **869**  
 with 4 pcs.  
 0,3 kg

**FORD** Transit



See all engine APPLICATIONS on the **THE TOOL FINDER™**

1.0	1.1	1.2	1.3	1.4	1.5	1.6	1.7	1.8	1.9
2.0	2.1	<b>2.2</b>	2.3	2.4	2.5	2.6	2.7	2.8	2.9
3.0	3.1	3.2	3.3	3.4	3.5	3.6	3.7	3.8	3.9
4.0	4.1	4.2	4.3	4.4	4.5	4.6	4.7	4.8	4.9

**G** TIMING TOOL SET SUITABLE FOR **FORD, MAZDA**

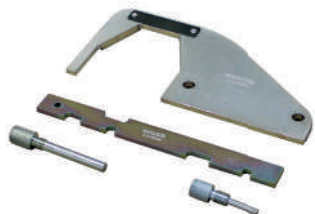

**GO** CODE **878**  
 with 4 pcs.  
 1,2 kg

**FORD** Mondeo  
**MAZDA** 3, 5, 6, CX-7, MPV, MX-5, Tribute



See all engine APPLICATIONS on the THE<sup>T</sup>OO<sup>L</sup>FINDER™

1.0	1.1	1.2	1.3	1.4	1.5	1.6	1.7	1.8	1.9
2.0	2.1	2.2	2.3	2.4	2.5	2.6	2.7	2.8	2.9
3.0	3.1	3.2	3.3	3.4	3.5	3.6	3.7	3.8	3.9
4.0	4.1	4.2	4.3	4.4	4.5	4.6	4.7	4.8	4.9

**G** TIMING TOOL SET SUITABLE FOR **FORD**



**GO** CODE **879**  
 with 6 pcs.  
 2,6 kg

**FORD** B-MAX, C-MAX, EcoSport, Fiesta, Focus, Focus C-MAX, Fusion, Galaxy, Grand C-MAX, Grand Tourneo Connect, Kuga, Mondeo, Puma, S-MAX, Tourneo Connect, Transit Connect

**MAZDA** 2  
**VOLVO** S60, S80, V40, V60, V70



See all engine APPLICATIONS on the THE<sup>T</sup>OO<sup>L</sup>FINDER™

1.0	1.1	1.2	1.3	1.4	1.5	1.6	1.7	1.8	1.9
2.0	2.1	2.2	2.3	2.4	2.5	2.6	2.7	2.8	2.9
3.0	3.1	3.2	3.3	3.4	3.5	3.6	3.7	3.8	3.9
4.0	4.1	4.2	4.3	4.4	4.5	4.6	4.7	4.8	4.9

**G** TIMING TOOL SET SUITABLE FOR **FORD**



**GO** CODE **873**  
 with 4 pcs.  
 0,9 kg

**FORD** EcoSport, Focus, Focus Active, Grand Tourneo Connect, Tourneo Connect, Transit Connect



See all engine APPLICATIONS on the THE<sup>T</sup>OO<sup>L</sup>FINDER™

1.0	1.1	1.2	1.3	1.4	1.5	1.6	1.7	1.8	1.9
2.0	2.1	2.2	2.3	2.4	2.5	2.6	2.7	2.8	2.9
3.0	3.1	3.2	3.3	3.4	3.5	3.6	3.7	3.8	3.9
4.0	4.1	4.2	4.3	4.4	4.5	4.6	4.7	4.8	4.9

**G** TIMING TOOL SET SUITABLE FOR **LAND ROVER**



**GO** CODE **779**  
 with 12 pcs.  
 3,1 kg

**LAND ROVER** Discovery, Discovery Sport, Range Rover Evoque, Range Rover Evoque Convertible, Range Rover Sport, Range Rover Velar

**JAGUAR** E-Pace, F-Pace, XE, XF



See all engine APPLICATIONS on the THE<sup>T</sup>OO<sup>L</sup>FINDER™

1.0	1.1	1.2	1.3	1.4	1.5	1.6	1.7	1.8	1.9
2.0	2.1	2.2	2.3	2.4	2.5	2.6	2.7	2.8	2.9
3.0	3.1	3.2	3.3	3.4	3.5	3.6	3.7	3.8	3.9
4.0	4.1	4.2	4.3	4.4	4.5	4.6	4.7	4.8	4.9

**G** TIMING TOOL SET SUITABLE FOR  
MERCEDES, <2011



**GO** CODE **853**  
T with 4 pcs.  
kg 1,6 kg

**MB** GLK, E-Class, E-Class Coupe/Cabriolet, GLK, C-Class, Sprinter, Vito, Viano, CLS, S-Class, C-Class Coupe, M-Class, B-Class, SLK, A-Class, CLA Coupe, GLA, V-Class, CLA Shooting Brake, GLE, GLC, Valente, SLC

**G** TIMING TOOL SET SUITABLE FOR  
MERCEDES, >2011



**GO** CODE **863**  
T with 3 pcs.  
kg 0,6 kg

**MB** GLK, Classe E, Classe E Coupe/Cabriolet, GLK, Classe C, Sprinter, Vito, Viano, CLS, Classe S, Classe C Coupe, Classe M, Classe B, SLK, Classe A, CLA Coupe, GLA, Classe V, CLA Shooting Brake, GLE, GLC, Valente, SLC

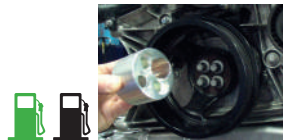

See all engine APPLICATIONS on the **THE TOOLFINDER™**

1.0	1.1	1.2	1.3	1.4	1.5	1.6	1.7	1.8	1.9
2.0	2.1	2.2	2.3	2.4	2.5	2.6	2.7	2.8	2.9
3.0	3.1	3.2	3.3	3.4	3.5	3.6	3.7	3.8	3.9
4.0	4.1	4.2	4.3	4.4	4.5	4.6	4.7	4.8	4.9

See all engine APPLICATIONS on the **THE TOOLFINDER™**

1.0	1.1	1.2	1.3	1.4	1.5	1.6	1.7	1.8	1.9
2.0	2.1	2.2	2.3	2.4	2.5	2.6	2.7	2.8	2.9
3.0	3.1	3.2	3.3	3.4	3.5	3.6	3.7	3.8	3.9
4.0	4.1	4.2	4.3	4.4	4.5	4.6	4.7	4.8	4.9

**G** TIMING TOOL SET SUITABLE FOR  
MERCEDES



**GO** CODE **854**  
T with 3 pcs.  
kg 2,7 kg

**MB** A-Class, B-Class, Citan, CLA Coupe, GLA

**G** TIMING TOOL SET SUITABLE FOR  
MERCEDES



**GO** CODE **730**  
T with 4 pcs.  
kg 2,7 kg

**MB** C-Class, C-Class Coupe, E-Class, E-Class Coupe/Cabriolet, SLK, CLC-Class, CLK, Sprinter

See all engine APPLICATIONS on the **THE TOOLFINDER™**

1.0	1.1	1.2	1.3	1.4	1.5	1.6	1.7	1.8	1.9
2.0	2.1	2.2	2.3	2.4	2.5	2.6	2.7	2.8	2.9
3.0	3.1	3.2	3.3	3.4	3.5	3.6	3.7	3.8	3.9
4.0	4.1	4.2	4.3	4.4	4.5	4.6	4.7	4.8	4.9

See all engine APPLICATIONS on the **THE TOOLFINDER™**

1.0	1.1	1.2	1.3	1.4	1.5	1.6	1.7	1.8	1.9
2.0	2.1	2.2	2.3	2.4	2.5	2.6	2.7	2.8	2.9
3.0	3.1	3.2	3.3	3.4	3.5	3.6	3.7	3.8	3.9
4.0	4.1	4.2	4.3	4.4	4.5	4.6	4.7	4.8	4.9

**G** TIMING TOOL SET SUITABLE FOR  
OPEL, VAUXHALL, CHEVROLET



**GO** CODE **821**  
T with 7 pcs.  
kg 4 kg

**OPEL/VAUXHALL** Corsa, Astra, Meriva, Zafira, Adam, Insigna  
**CHEVROLET** Aveo, Cruze, Trax

**G** TIMING TOOL SET SUITABLE FOR  
OPEL, VAUXHALL, CHEVROLET



**GO** CODE **732**  
T with 6 pcs.  
kg 4 kg

**OPEL/VAUXHALL** Corsa, Astra, Meriva, Zafira, Adam, Insigna  
**CHEVROLET** Aveo, Cruze, Trax



See all engine APPLICATIONS on the **THE TOOLFINDER™**

1.0	1.1	1.2	1.3	1.4	1.5	1.6	1.7	1.8	1.9
2.0	2.1	2.2	2.3	2.4	2.5	2.6	2.7	2.8	2.9
3.0	3.1	3.2	3.3	3.4	3.5	3.6	3.7	3.8	3.9
4.0	4.1	4.2	4.3	4.4	4.5	4.6	4.7	4.8	4.9



See all engine APPLICATIONS on the **THE TOOLFINDER™**

1.0	1.1	1.2	1.3	1.4	1.5	1.6	1.7	1.8	1.9
2.0	2.1	2.2	2.3	2.4	2.5	2.6	2.7	2.8	2.9
3.0	3.1	3.2	3.3	3.4	3.5	3.6	3.7	3.8	3.9
4.0	4.1	4.2	4.3	4.4	4.5	4.6	4.7	4.8	4.9

**G** TIMING TOOL SET SUITABLE FOR  
OPEL, VAUXHALL, CHEVROLET



**GO** CODE **728**  
T with 6 pcs.  
kg 0,8 kg

**OPEL/VAUXHALL** Corsa-D, Astra-GH, Meriva-A, Zafira-B, Zafira-C Tourer, Vectra-C, Signum, Insigna, Vectra-C  
**CHEVROLET** Aveo, Cruze, Orlando

**G** TIMING TOOL SET SUITABLE FOR  
OPEL, VAUXHALL, CHEVROLET



**GO** CODE **782**  
T with 9 pcs.  
kg 2 kg

**OPEL/VAUXHALL** Antara  
**CHEVROLET** Lacetti, Nubira, Captiva, Epica, Cruze



See all engine APPLICATIONS on the **THE TOOLFINDER™**

1.0	1.1	1.2	1.3	1.4	1.5	1.6	1.7	1.8	1.9
2.0	2.1	2.2	2.3	2.4	2.5	2.6	2.7	2.8	2.9
3.0	3.1	3.2	3.3	3.4	3.5	3.6	3.7	3.8	3.9
4.0	4.1	4.2	4.3	4.4	4.5	4.6	4.7	4.8	4.9



See all engine APPLICATIONS on the **THE TOOLFINDER™**

1.0	1.1	1.2	1.3	1.4	1.5	1.6	1.7	1.8	1.9
2.0	2.1	2.2	2.3	2.4	2.5	2.6	2.7	2.8	2.9
3.0	3.1	3.2	3.3	3.4	3.5	3.6	3.7	3.8	3.9
4.0	4.1	4.2	4.3	4.4	4.5	4.6	4.7	4.8	4.9



**G** TIMING TOOL SET SUITABLE FOR  
OPEL, VAUXHALL

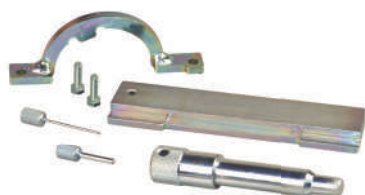

**GO** CODE **739**  
T with 7 pcs.  
kg 1,4 kg

**OPEL/VAUXHALL** Corsa-B, Astra-G, Agila, Corsa-C, Corsa-D, Astra-G Classic II, Astra-H, Combo-C, Meriva-A, Tigra-B

**G** TIMING TOOL SET SUITABLE FOR  
OPEL, VAUXHALL



**GO** CODE **789**  
T with 5 pcs.  
kg 0,6 kg

**OPEL/VAUXHALL** Agila, B, Astra-H, J, Combo-C, D, Corsa-C, D, Meriva-A, B, Tigra-B, Zafira-B, Family



See all engine APPLICATIONS on the THE**TOOL**FINDER™

1.0	1.1	1.2	1.3	1.4	1.5	1.6	1.7	1.8	1.9
2.0	2.1	2.2	2.3	2.4	2.5	2.6	2.7	2.8	2.9
3.0	3.1	3.2	3.3	3.4	3.5	3.6	3.7	3.8	3.9
4.0	4.1	4.2	4.3	4.4	4.5	4.6	4.7	4.8	4.9



See all engine APPLICATIONS on the THE**TOOL**FINDER™

1.0	1.1	1.2	1.3	1.4	1.5	1.6	1.7	1.8	1.9
2.0	2.1	2.2	2.3	2.4	2.5	2.6	2.7	2.8	2.9
3.0	3.1	3.2	3.3	3.4	3.5	3.6	3.7	3.8	3.9
4.0	4.1	4.2	4.3	4.4	4.5	4.6	4.7	4.8	4.9

**G** TIMING TOOL SET SUITABLE FOR  
OPEL, VAUXHALL, CHEVROLET



**GO** CODE **766**  
T with 6 pcs.  
kg 1,1 kg

**OPEL/VAUXHALL** Antara  
**CHEVROLET** Epica, Lacetti, Nubira, Captiva

**G** TIMING TOOL SET SUITABLE FOR  
OPEL, VAUXHALL



**GO** CODE **775**  
T with 2 pcs.  
kg 0,7 kg

**OPEL/VAUXHALL** Astra-G, Vectra-B, Vectra-C, VX220/Speedster, Zafira-A, Astra-H, Signum, Zafira-B/Zafira Family



See all engine APPLICATIONS on the THE**TOOL**FINDER™

1.0	1.1	1.2	1.3	1.4	1.5	1.6	1.7	1.8	1.9
2.0	2.1	2.2	2.3	2.4	2.5	2.6	2.7	2.8	2.9
3.0	3.1	3.2	3.3	3.4	3.5	3.6	3.7	3.8	3.9
4.0	4.1	4.2	4.3	4.4	4.5	4.6	4.7	4.8	4.9



See all engine APPLICATIONS on the THE**TOOL**FINDER™

1.0	1.1	1.2	1.3	1.4	1.5	1.6	1.7	1.8	1.9
2.0	2.1	2.2	2.3	2.4	2.5	2.6	2.7	2.8	2.9
3.0	3.1	3.2	3.3	3.4	3.5	3.6	3.7	3.8	3.9
4.0	4.1	4.2	4.3	4.4	4.5	4.6	4.7	4.8	4.9

**G** TIMING TOOL SET SUITABLE FOR  
**OPEL, VAUXHALL**



**GO** CODE **720**  
1 with 5 pcs.  
kg 2,3 kg

**OPEL/ VAUXHALL** AstraJ, Astra-K, GTC, Insignia, Meriva-B, Mokka, Zafira-C Tourer

**G** TIMING TOOL SET SUITABLE FOR  
**OPEL**



**GO** CODE **874**  
1 with 6 pcs.  
kg 0,2 kg

**OPEL/ VAUXHALL** Combo-E/Combo-E Life, Crossland X, Grandland X, Vivaro-C/Vivaro-C Life  
**PEUGEOT** Expert IV, Traveller



See all engine APPLICATIONS on the THE<sup>TOOL</sup>FINDER™

1.0	1.1	1.2	1.3	1.4	1.5	1.6	1.7	1.8	1.9
2.0	2.1	2.2	2.3	2.4	2.5	2.6	2.7	2.8	2.9
3.0	3.1	3.2	3.3	3.4	3.5	3.6	3.7	3.8	3.9
4.0	4.1	4.2	4.3	4.4	4.5	4.6	4.7	4.8	4.9



See all engine APPLICATIONS on the THE<sup>TOOL</sup>FINDER™

1.0	1.1	1.2	1.3	1.4	1.5	1.6	1.7	1.8	1.9
2.0	2.1	2.2	2.3	2.4	2.5	2.6	2.7	2.8	2.9
3.0	3.1	3.2	3.3	3.4	3.5	3.6	3.7	3.8	3.9
4.0	4.1	4.2	4.3	4.4	4.5	4.6	4.7	4.8	4.9

**G** TIMING TOOL SET SUITABLE FOR  
**OPEL, VAUXHALL**



**GO** CODE **830**  
1 with 3 pcs.  
kg 1 kg

**OPEL/ VAUXHALL** Adam, Adam Rocks, Astra-K, Corsa-E



See all engine APPLICATIONS on the THE<sup>TOOL</sup>FINDER™

1.0	1.1	1.2	1.3	1.4	1.5	1.6	1.7	1.8	1.9
2.0	2.1	2.2	2.3	2.4	2.5	2.6	2.7	2.8	2.9
3.0	3.1	3.2	3.3	3.4	3.5	3.6	3.7	3.8	3.9
4.0	4.1	4.2	4.3	4.4	4.5	4.6	4.7	4.8	4.9

**G** TIMING TOOL SET SUITABLE FOR  
**OPEL, VAUXHALL**



**GO** CODE **866**  
1 with 16 pcs.  
kg 3,2 kg

**OPEL/ VAUXHALL** Cascada, Insignia-A, Insignia-A Country Tourer, Zafira-C Tourer



See all engine APPLICATIONS on the THE<sup>TOOL</sup>FINDER™

1.0	1.1	1.2	1.3	1.4	1.5	1.6	1.7	1.8	1.9
2.0	2.1	2.2	2.3	2.4	2.5	2.6	2.7	2.8	2.9
3.0	3.1	3.2	3.3	3.4	3.5	3.6	3.7	3.8	3.9
4.0	4.1	4.2	4.3	4.4	4.5	4.6	4.7	4.8	4.9

**G** TIMING TOOL SET SUITABLE FOR  
OPEL, VAUXHALL



**GO** CODE **871**  
 with 12 pcs.  
 1,9 kg

**OPEL/VAUXHALL** Corsa E

**G** TIMING TOOL SET SUITABLE FOR  
PSA

**NEW**



**GO** CODE **833**  
 with 1 pcs.  
 0,35 kg

**OPEL** Crossland, Grandland  
**CITROËN** C3, C3 Aircross, Cactus, Grand Picasso, Picasso, Spacetourer, Grand Spacetourer  
**PEUGEOT** 2008, 208, 3008, 308, 5008

See all engine APPLICATIONS on the THE**TOOL**FINDER™

1.0	1.1	1.2	1.3	1.4	1.5	1.6	1.7	1.8	1.9
2.0	2.1	2.2	2.3	2.4	2.5	2.6	2.7	2.8	2.9
3.0	3.1	3.2	3.3	3.4	3.5	3.6	3.7	3.8	3.9
4.0	4.1	4.2	4.3	4.4	4.5	4.6	4.7	4.8	4.9

See all engine APPLICATIONS on the THE**TOOL**FINDER™

1.0	1.1	1.2	1.3	1.4	1.5	1.6	1.7	1.8	1.9
2.0	2.1	2.2	2.3	2.4	2.5	2.6	2.7	2.8	2.9
3.0	3.1	3.2	3.3	3.4	3.5	3.6	3.7	3.8	3.9
4.0	4.1	4.2	4.3	4.4	4.5	4.6	4.7	4.8	4.9

**G** TIMING TOOL SET SUITABLE FOR PSA

**NEW**



**GO** CODE **831**  
 with 4 pcs.  
 2 kg

**FIAT** 500, 500C, Panda

**G** TIMING TOOL SET SUITABLE FOR PSA,  
OPEL



**GO** CODE **882**  
 with 4 pcs.  
 1,6 kg

**PEUGEOT** 208 / 2008 (2012 ÷ 2014)  
**CITROËN** C3 (III)

See all engine APPLICATIONS on the THE**TOOL**FINDER™

1.0	1.1	1.2	1.3	1.4	1.5	1.6	1.7	1.8	1.9
2.0	2.1	2.2	2.3	2.4	2.5	2.6	2.7	2.8	2.9
3.0	3.1	3.2	3.3	3.4	3.5	3.6	3.7	3.8	3.9
4.0	4.1	4.2	4.3	4.4	4.5	4.6	4.7	4.8	4.9

See all engine APPLICATIONS on the THE**TOOL**FINDER™

1.0	1.1	1.2	1.3	1.4	1.5	1.6	1.7	1.8	1.9
2.0	2.1	2.2	2.3	2.4	2.5	2.6	2.7	2.8	2.9
3.0	3.1	3.2	3.3	3.4	3.5	3.6	3.7	3.8	3.9
4.0	4.1	4.2	4.3	4.4	4.5	4.6	4.7	4.8	4.9



**G** TIMING TOOL SET SUITABLE FOR  
**PSA**



**GO** CODE **721**  
with 25 pcs.  
3,2 kg

**PEUGEOT** 1007, 106, 107, 205, 206, 206 CC, 206+, 207, 207 CC, 3008, 306, 307, 307 CC, 308, 308 CC, 309, 405, 406, 406 Coupe, 407, 407 Coupe, 5008, 508, 605, 607, 806, 807, Bipper, Boxer, Boxer II, Expert I/II, Expert III, J5, Partner, Partner III, Partner/Partner Origin/Ranch I/II, RCZ



See all engine APPLICATIONS on the **THE TOOLFINDER™**

1.0	1.1	1.2	1.3	1.4	1.5	1.6	1.7	1.8	1.9
2.0	2.1	2.2	2.3	2.4	2.5	2.6	2.7	2.8	2.9
3.0	3.1	3.2	3.3	3.4	3.5	3.6	3.7	3.8	3.9
4.0	4.1	4.2	4.3	4.4	4.5	4.6	4.7	4.8	4.9

**G** TIMING TOOL SET SUITABLE FOR  
**PSA, OPEL**



**GO** CODE **885**  
with 7 pcs.  
1,95 kg

**PEUGEOT** 108, 208, 2008, Partner, 208 E, 308 E, RIFTER E, 5008E, 3008 E, 2008 E, PARTNER VU E

**CITROËN** C3, C3 Aircross

**OPEL** Crossland, Crossland X



See all engine APPLICATIONS on the **THE TOOLFINDER™**

1.0	1.1	1.2	1.3	1.4	1.5	1.6	1.7	1.8	1.9
2.0	2.1	2.2	2.3	2.4	2.5	2.6	2.7	2.8	2.9
3.0	3.1	3.2	3.3	3.4	3.5	3.6	3.7	3.8	3.9
4.0	4.1	4.2	4.3	4.4	4.5	4.6	4.7	4.8	4.9

**G** TIMING TOOL SET SUITABLE FOR  
**PSA**



**GO** CODE **781**  
with 21 pcs.  
2 kg

**CITROËN** C8, C4 Picasso/Grand Picasso, C5 II, C5 III, BX, ZX, Xantia, AX, C15, C2, C3 I/II/First/Classic, C3 Pluriel, Nemo, Berlingo/Berlingo First I/II, Saxo, Xsara II, Xsara, Synergie/Evasion, Berlingo III, C4, Xsara Picasso, C4 Sedan, XM, Dispatch/Jumpy III, Relay Jumper II, C5, Dispatch/Jumpy I/II, Relay/Jumper

**PEUGEOT** 307, 307 CC, 308, 407, 807, Expert III, 206, 206 CC, 406, 406 Coupe, 607, 806, Expert I/II, 407 Coupe, 205, 306, 309, Partner/Partner Origin/Ranch I/II, 405, 1007, 207, Bipper, 106, Partner III, 605, Boxer II, Boxer



See all engine APPLICATIONS on the **THE TOOLFINDER™**

1.0	1.1	1.2	1.3	1.4	1.5	1.6	1.7	1.8	1.9
2.0	2.1	2.2	2.3	2.4	2.5	2.6	2.7	2.8	2.9
3.0	3.1	3.2	3.3	3.4	3.5	3.6	3.7	3.8	3.9
4.0	4.1	4.2	4.3	4.4	4.5	4.6	4.7	4.8	4.9

**G** TIMING TOOL SET SUITABLE FOR  
**PSA**



**GO** CODE **719**  
with 2 pcs.  
1,4 kg

**CITROËN** C1 II, C4 Cactus, C3 III, DS3/DS3 Cabrio

**PEUGEOT** 208, 2008, 308, 108



See all engine APPLICATIONS on the **THE TOOLFINDER™**

1.0	1.1	1.2	1.3	1.4	1.5	1.6	1.7	1.8	1.9
2.0	2.1	2.2	2.3	2.4	2.5	2.6	2.7	2.8	2.9
3.0	3.1	3.2	3.3	3.4	3.5	3.6	3.7	3.8	3.9
4.0	4.1	4.2	4.3	4.4	4.5	4.6	4.7	4.8	4.9



**NEW**

**G** TIMING TOOL SET SUITABLE FOR PSA



**GO** CODE **883**  
 with 3 pcs.  
 0,35 kg

**PEUGEOT** 108, 208, 2008, Partner, 208 E, 308 E, RIFTER E, 5008E, 3008 E, 2008 E, PARTNER VU E

**G** TIMING TOOL SET SUITABLE FOR RENAULT, MERCEDES



**GO** CODE **884**  
 with 11 pcs.  
 0,68 kg

**RENAULT** Arkana (2019-), Captur (2018-), Clio V (2019-), Kadjar (2018-), Megane IV (2017-), Scenic/Grand Scenic (2018-), Talisman (2018-)

**DACIA** Dokker, Duster, Lodgy

**MERCEDES** Classe A W177 A200 (2019-), Classe B W247 B180, (2019-), CLA (2019-), GLA (2019-), GLB (2019-)



See all engine APPLICATIONS on the THE**TOOL**FINDER™

1.0	1.1	1.2	1.3	1.4	1.5	1.6	1.7	1.8	1.9
2.0	2.1	2.2	2.3	2.4	2.5	2.6	2.7	2.8	2.9
3.0	3.1	3.2	3.3	3.4	3.5	3.6	3.7	3.8	3.9
4.0	4.1	4.2	4.3	4.4	4.5	4.6	4.7	4.8	4.9

See all engine APPLICATIONS on the THE**TOOL**FINDER™

1.0	1.1	1.2	1.3	1.4	1.5	1.6	1.7	1.8	1.9
2.0	2.1	2.2	2.3	2.4	2.5	2.6	2.7	2.8	2.9
3.0	3.1	3.2	3.3	3.4	3.5	3.6	3.7	3.8	3.9
4.0	4.1	4.2	4.3	4.4	4.5	4.6	4.7	4.8	4.9

**G** TIMING TOOL SET SUITABLE FOR RENAULT, NISSAN, DACIA

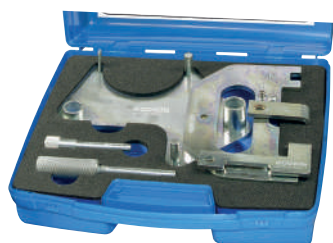

**GO** CODE **725**  
 with 6 pcs.  
 2,4 kg

**RENAULT** Clio, Clio sport, Megane, Scenic, Laguna, Espace

**NISSAN** Kubistar, Primastar

**DACIA** Duster, Logan, Sandero



See all engine APPLICATIONS on the THE**TOOL**FINDER™

1.0	1.1	1.2	1.3	1.4	1.5	1.6	1.7	1.8	1.9
2.0	2.1	2.2	2.3	2.4	2.5	2.6	2.7	2.8	2.9
3.0	3.1	3.2	3.3	3.4	3.5	3.6	3.7	3.8	3.9
4.0	4.1	4.2	4.3	4.4	4.5	4.6	4.7	4.8	4.9

**G** TIMING TOOL SET SUITABLE FOR RENAULT, NISSAN



**GO** CODE **765**  
 with 3 pcs.  
 0,8 kg

**RENAULT** Koleos, Megane III, Scenic/Grand Scenic III, Trafic II, Megane II, Scenic/Grand Scenic II, Espace/Grand Espace IV, Laguna II, Vel Satis, Laguna III, Latitude

**NISSAN** Qashqai/Qashqai+2, X-Trail, Primastar



See all engine APPLICATIONS on the THE**TOOL**FINDER™

1.0	1.1	1.2	1.3	1.4	1.5	1.6	1.7	1.8	1.9
2.0	2.1	2.2	2.3	2.4	2.5	2.6	2.7	2.8	2.9
3.0	3.1	3.2	3.3	3.4	3.5	3.6	3.7	3.8	3.9
4.0	4.1	4.2	4.3	4.4	4.5	4.6	4.7	4.8	4.9

**G** TIMING TOOL SET SUITABLE FOR  
**RENAULT, NISSAN**



**GO** CODE **707**  
with 5 pcs.  
1,9 kg

- RENAULT** Koleos, Megane III, Scenic/Grand Scenic III, Trafic II, Megane II, Scenic/Grand Scenic II, Espace Grand Espace IV, Laguna II, Vel Satis, Laguna III, Latitude, Master III
- NISSAN** Qashqai/Qashqai+2, X-Trail, Primastar, NV400



See all engine APPLICATIONS on the **THE TOOLFINDER™**

1.0	1.1	1.2	1.3	1.4	1.5	1.6	1.7	1.8	1.9
2.0	2.1	2.2	2.3	2.4	2.5	2.6	2.7	2.8	2.9
3.0	3.1	3.2	3.3	3.4	3.5	3.6	3.7	3.8	3.9
4.0	4.1	4.2	4.3	4.4	4.5	4.6	4.7	4.8	4.9

**G** TIMING TOOL SET SUITABLE FOR  
**RENAULT, NISSAN**



**GO** CODE **709**  
with 4 pcs.  
2,7 kg

- RENAULT** Megane, Scenic, Grand Scenic
- NISSAN** Qashqai, Qashqai+2



See all engine APPLICATIONS on the **THE TOOLFINDER™**

1.0	1.1	1.2	1.3	1.4	1.5	1.6	1.7	1.8	1.9
2.0	2.1	2.2	2.3	2.4	2.5	2.6	2.7	2.8	2.9
3.0	3.1	3.2	3.3	3.4	3.5	3.6	3.7	3.8	3.9
4.0	4.1	4.2	4.3	4.4	4.5	4.6	4.7	4.8	4.9

**G** TIMING TOOL SET SUITABLE FOR  
**RENAULT, NISSAN, SUZUKI, DACIA**



**GO** CODE **750**  
with 2 pcs.  
0,3 kg

- RENAULT** Captur, Clio IV, Kangoo II/Be Bop, Kangoo/Grand Kangoo II, Megane III, Scenic XMOD, Scenic/Grand Scenic III, Clio II/Clio Campus/Clio Storia, Clio Symbol/Symbol, Kangoo, Thalia, Twingo II, Megane II, Scenic/Grand Scenic II, Clio III/ Clio Collection, Modus, Modus/Grand Modus II, Laguna III, Latitude, Logan, Logan MCV, Fluence
- NISSAN** Almera, Cube, Evalia, Juke, Micra, Note, NV200, Qashqai/Qashqai+2, Tiida, Pulsar, Qashqai, Kubistar
- SUZUKI** Jimny
- DACIA** Dokker, Lodgy, Logan, Logan MCV, Sandero, Duster, Logan Pick-up, Logan Van/Express



See all engine APPLICATIONS on the **THE TOOLFINDER™**

1.0	1.1	1.2	1.3	1.4	1.5	1.6	1.7	1.8	1.9
2.0	2.1	2.2	2.3	2.4	2.5	2.6	2.7	2.8	2.9
3.0	3.1	3.2	3.3	3.4	3.5	3.6	3.7	3.8	3.9
4.0	4.1	4.2	4.3	4.4	4.5	4.6	4.7	4.8	4.9

**G** TIMING TOOL SET SUITABLE FOR  
**RENAULT, NISSAN**



**GO** CODE **727**  
with 14 pcs.  
2,3 kg

- RENAULT** Clio, Kangoo, Laguna, Espace, Master, Mégane/Scénic, Trafic, Thalia, Modus, Twingo, Be Bop, Fluence, Logan



See all engine APPLICATIONS on the **THE TOOLFINDER™**

1.0	1.1	1.2	1.3	1.4	1.5	1.6	1.7	1.8	1.9
2.0	2.1	2.2	2.3	2.4	2.5	2.6	2.7	2.8	2.9
3.0	3.1	3.2	3.3	3.4	3.5	3.6	3.7	3.8	3.9
4.0	4.1	4.2	4.3	4.4	4.5	4.6	4.7	4.8	4.9

**G** **TIMING TOOL SET SUITABLE FOR  
RENAULT, NISSAN, DACIA**



**GO** **733**  
with 5 pcs.  
1,6 kg

**RENAULT** Laguna II, Megane, Scenic, Laguna, Espace/Grand Espace, Trafic II, Clio II/Clio Campus/Clio Storia, Megane Scenic, Scenic RX4, Megane II, Scenic/Grand Scenic II, Espace/Grand Espace IV, Clio III/ Clio Collection, Clio Symbol/Symbol, Symbol, Thalia, Modus, Modus/Grand Modus II, Logan, Logan MCV, Kangoo, Laguna III, Kangoo II/Be Bop, Kangoo/ Grand Kangoo II, Fluence, Megane III, Twingo II, Wind, Scenic/Grand Scenic III, Scenic XMOD

**NISSAN** Primastar, Kubistar

**DACIA** Duster, Logan, Logan MCV, Sandero



See all engine APPLICATIONS on the **THE TOOLFINDER™**

1.0	1.1	1.2	1.3	1.4	1.5	1.6	1.7	1.8	1.9
2.0	2.1	2.2	2.3	2.4	2.5	2.6	2.7	2.8	2.9
3.0	3.1	3.2	3.3	3.4	3.5	3.6	3.7	3.8	3.9
4.0	4.1	4.2	4.3	4.4	4.5	4.6	4.7	4.8	4.9

**G** **TIMING TOOL SET SUITABLE FOR  
RENAULT, NISSAN, DACIA, SUZUKI**



**GO** CODE **740**  
with 6 pcs.  
1,7 kg

**RENAULT** Megane, Scenic, Laguna II, Espace/Grand Espace IV, Laguna, Espace/Grand Espace II, Megane, Scenic, Laguna, Espace/Grand Espace, Trafic II, Clio II/Clio Campus/Clio Storia, Megane Scenic, Scenic RX4, Megane II, Scenic/Grand Scenic II, Espace/Grand Espace IV, Clio III/Clio Collection, Clio Symbol/Symbol, Symbol, Thalia, Modus, Modus/Grand Modus II, Logan, Logan MCV, Kangoo, Laguna III, Kangoo II/Be Bop, Kangoo/Grand Kangoo II, Fluence, Megane III, Twingo II, Wind, Scenic Grand Scenic III, Scenic XMOD, Captur, Clio IV, Latitude

**NISSAN** Primastar, Kubistar, Almera, Cube, Evalia, Juke, Micra, Note, NV200, Qashqai/Qashqai+2, Tiida, Pulsar, Qashqai

**SUZUKI** Jimny

**DACIA** Duster, Logan, Logan MCV, Sandero, Dokker, Lodgy, Logan Pick-up, Logan Van/Express



See all engine APPLICATIONS on the **THE TOOLFINDER™**

1.0	1.1	1.2	1.3	1.4	1.5	1.6	1.7	1.8	1.9
2.0	2.1	2.2	2.3	2.4	2.5	2.6	2.7	2.8	2.9
3.0	3.1	3.2	3.3	3.4	3.5	3.6	3.7	3.8	3.9
4.0	4.1	4.2	4.3	4.4	4.5	4.6	4.7	4.8	4.9

**G** TIMING TOOL SET SUITABLE FOR SAAB



**GO** CODE **817**  
T with 4 pcs.  
kg 0,5 kg

SAAB 9-3

**G** TIMING TOOL SET SUITABLE FOR SAAB



**GO** CODE **819**  
T with 10 pcs.  
kg 3 kg

SAAB 9-3, 9-5

See all engine APPLICATIONS on the THE<sup>TOOL</sup>FINDER™

1.0	1.1	1.2	1.3	1.4	1.5	1.6	1.7	1.8	1.9
2.0	2.1	2.2	2.3	2.4	2.5	2.6	2.7	2.8	2.9
3.0	3.1	3.2	3.3	3.4	3.5	3.6	3.7	3.8	3.9
4.0	4.1	4.2	4.3	4.4	4.5	4.6	4.7	4.8	4.9



See all engine APPLICATIONS on the THE<sup>TOOL</sup>FINDER™

1.0	1.1	1.2	1.3	1.4	1.5	1.6	1.7	1.8	1.9
2.0	2.1	2.2	2.3	2.4	2.5	2.6	2.7	2.8	2.9
3.0	3.1	3.2	3.3	3.4	3.5	3.6	3.7	3.8	3.9
4.0	4.1	4.2	4.3	4.4	4.5	4.6	4.7	4.8	4.9



**G** TIMING TOOL SET SUITABLE FOR TOYOTA



**GO** CODE **881**  
T with 12 pcs.  
kg 2,3 kg

TOYOTA Proace/Proace Verso

**G** TIMING TOOL SET SUITABLE FOR TOYOTA, PSA



**GO** CODE **768**  
T with 15 pcs.  
kg 3,6 kg

TOYOTA Proace

**CITROËN** Berlingo/Berlingo First I/II, C4, C4 Picasso/Grand Picasso, C4 SpaceTourer/Grand SpaceTourer, C4 Sedan, C5, C6, C8, C-Crosser, Dispatch/Jumpy, DS4/Crossback, DS5, Relay/Jumper, SpaceTourer, Xsara II, Xsara Picasso

**PEUGEOT** 206, 306, 307/CC, 308/CC, 406, 407, 407 Coupe, 508, 607, 807, 3008, 4007, 5008, Boxer III, Expert, Partner/Partner Origin/Ranch I/II, RCZ, Traveller



See all engine APPLICATIONS on the THE<sup>TOOL</sup>FINDER™

1.0	1.1	1.2	1.3	1.4	1.5	1.6	1.7	1.8	1.9
2.0	2.1	2.2	2.3	2.4	2.5	2.6	2.7	2.8	2.9
3.0	3.1	3.2	3.3	3.4	3.5	3.6	3.7	3.8	3.9
4.0	4.1	4.2	4.3	4.4	4.5	4.6	4.7	4.8	4.9

See all engine APPLICATIONS on the THE<sup>TOOL</sup>FINDER™

1.0	1.1	1.2	1.3	1.4	1.5	1.6	1.7	1.8	1.9
2.0	2.1	2.2	2.3	2.4	2.5	2.6	2.7	2.8	2.9
3.0	3.1	3.2	3.3	3.4	3.5	3.6	3.7	3.8	3.9
4.0	4.1	4.2	4.3	4.4	4.5	4.6	4.7	4.8	4.9



**G** TIMING TOOL SET SUITABLE FOR VOLVO



**GO** CODE **815**  
 with 5 pcs.  
 0,4 kg

**VOLVO** C30, S40, V50, S80, V70

**G** CRANKSHAFT PULLEY HOLDING TOOL VOLVO



**GO** CODE **816**  
 with 1 pcs.  
 0,5 kg

**VOLVO** C30, C70, S40, V50, S80, V70, S60, V60, XC60, XC70, V40, XC90

**FORD** Mondeo, Galaxy, SMAX, Focus, Kuga

See all engine APPLICATIONS on the **THE TOOLFINDER™**

1.0	1.1	1.2	1.3	1.4	1.5	1.6	1.7	1.8	1.9
2.0	2.1	2.2	2.3	2.4	2.5	2.6	2.7	2.8	2.9
3.0	3.1	3.2	3.3	3.4	3.5	3.6	3.7	3.8	3.9
4.0	4.1	4.2	4.3	4.4	4.5	4.6	4.7	4.8	4.9

See all engine APPLICATIONS on the **THE TOOLFINDER™**

1.0	1.1	1.2	1.3	1.4	1.5	1.6	1.7	1.8	1.9
2.0	2.1	2.2	2.3	2.4	2.5	2.6	2.7	2.8	2.9
3.0	3.1	3.2	3.3	3.4	3.5	3.6	3.7	3.8	3.9
4.0	4.1	4.2	4.3	4.4	4.5	4.6	4.7	4.8	4.9

**G** TIMING TOOL SET SUITABLE FOR VOLVO



**GO** CODE **814**  
 with 7 pcs.  
 1,6 kg

**VOLVO** C30, S40, S80, V50, V70, C70

**G** TIMING TOOL SET SUITABLE FOR VOLVO



**GO** CODE **774**  
 with 4 pcs.  
 1,1 kg

**VOLVO** S40, V40, S70, V70, 850, C70, S80, S60, XC70, Cross Country, XC90

See all engine APPLICATIONS on the **THE TOOLFINDER™**

1.0	1.1	1.2	1.3	1.4	1.5	1.6	1.7	1.8	1.9
2.0	2.1	2.2	2.3	2.4	2.5	2.6	2.7	2.8	2.9
3.0	3.1	3.2	3.3	3.4	3.5	3.6	3.7	3.8	3.9
4.0	4.1	4.2	4.3	4.4	4.5	4.6	4.7	4.8	4.9

See all engine APPLICATIONS on the **THE TOOLFINDER™**

1.0	1.1	1.2	1.3	1.4	1.5	1.6	1.7	1.8	1.9
2.0	2.1	2.2	2.3	2.4	2.5	2.6	2.7	2.8	2.9
3.0	3.1	3.2	3.3	3.4	3.5	3.6	3.7	3.8	3.9
4.0	4.1	4.2	4.3	4.4	4.5	4.6	4.7	4.8	4.9

**G** CAMSHAFT ASSEMBLY DEVICE  
VW GROUP, PORSCHE

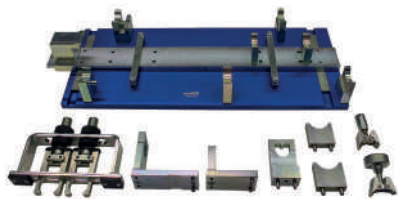

**GO** CODE **822**  
1 with 15 pcs.  
12 kg

- AUDI** A1/A1 Sportback, A3 Cabrio, A3/A3 Sportback, A4, A4 allroad, A4 Cabrio, A4 quattro, A5 Cabriolet, A5 Coupe, A5 Sportback, A6, A6 quattro, A8, Q3, Q5, Q7, TT
- SKODA** Fabia II, Octavia II, Praktik, Rapid, Rapid Spaceback, Roomster, Superb II, Yeti, Yeti Outdoor
- SEAT** Alhambra, Altea/Altea XL, Exeo, Ibiza, Leon, Toledo
- VW** Amarok, Beetle/Coccinelle/Maggiolino, Caddy/Caddy Maxi, CC, Crafter, Eos, Golf Plus, Golf V Estate, Golf VI, Golf VI Cabrio, Golf VI Estate, Jetta, Passat, Passat Alltrack, Passat CC, Phaeton, Polo, Scirocco, Sharan, Tiguan, Touareg, Touran, Transporter T5, Transporter T6, Transporter T7, Transporter T8, Transporter T9, Transporter T10, Transporter T11, Transporter T12, Transporter T13, Transporter T14

**PORSCHE** Cayenne

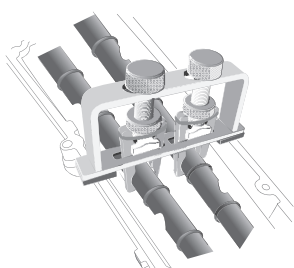

See all engine APPLICATIONS on the **THE TOOLFINDER**<sup>™</sup>

1.0	1.1	1.2	1.3	1.4	1.5	1.6	1.7	1.8	1.9
2.0	2.1	2.2	2.3	2.4	2.5	2.6	2.7	2.8	2.9
3.0	3.1	3.2	3.3	3.4	3.5	3.6	3.7	3.8	3.9
4.0	4.1	4.2	4.3	4.4	4.5	4.6	4.7	4.8	4.9

**G** TIMING TOOL SET SUITABLE FOR  
VW GROUP



**GO** CODE **757**  
1 with 16 pcs.  
2,7 kg

- AUDI** A4, A4 quattro, A6, A6 quattro, A8, Cabriolet, Allroad, A2, A3, A4 Cabrio, A3 Cabrio, A4 allroad, A5 Coupe/Cabriolet, A5 Sportback, Q5, A5 Cabriolet, A1, T
- SKODA** Fabia, Octavia/Octavia Tour, Superb, Roomster, Octavia II, Superb II, Fabia II, Praktik, Rapid, Rapid Spaceback, Yeti, Yeti Outdoor
- SEAT** Cordoba, Ibiza, Arosa, Alhambra, Toledo, Leon, Inca, Altea/Altea XL, Exeo
- VW** Passat, Polo, Lupo, LT, Caddy, Golf III, Golf III Cabrio, Golf III Estate, Golf IV Cabrio, Polo Classic, Sharan, Vento, Bora, Golf IV, Golf IV Estate, Transporter T4, Polo Estate, Beetle, Touran, Transporter T5, Golf Plus, Golf V, Golf V Estate, Jetta, Caddy/Caddy Maxi, Tiguan, Eos, Fox, Golf VI, Golf VI Estate, Beetle/Maggiolino, Golf VI Cabrio, Passat CC, Scirocco



See all engine APPLICATIONS on the **THE TOOLFINDER**<sup>™</sup>

1.0	1.1	1.2	1.3	1.4	1.5	1.6	1.7	1.8	1.9
2.0	2.1	2.2	2.3	2.4	2.5	2.6	2.7	2.8	2.9
3.0	3.1	3.2	3.3	3.4	3.5	3.6	3.7	3.8	3.9
4.0	4.1	4.2	4.3	4.4	4.5	4.6	4.7	4.8	4.9

**G** TIMING TOOL SET SUITABLE FOR  
VW GROUP



**GO** CODE **755**  
1 with 8 pcs.  
5 kg

**VW** Touareg, Transporter



See all engine APPLICATIONS on the **THE TOOLFINDER**<sup>™</sup>

1.0	1.1	1.2	1.3	1.4	1.5	1.6	1.7	1.8	1.9
2.0	2.1	2.2	2.3	2.4	2.5	2.6	2.7	2.8	2.9
3.0	3.1	3.2	3.3	3.4	3.5	3.6	3.7	3.8	3.9
4.0	4.1	4.2	4.3	4.4	4.5	4.6	4.7	4.8	4.9

**G** TIMING TOOL SET SUITABLE FOR  
VW GROUP



**GO** CODE **745**  
T with 8 pcs.  
kg 1 kg

- AUDI** 80, A4, A6, Cabriolet, A4 quattro, A6 quattro, A2, A3, A3 Cabrio, A4 Cabrio
- SKODA** Fabia, Octavia/Octavia Tour, Superb, Roomster, Octavia II, Superb II, Fabia II, Praktik
- SEAT** Alhambra, Cordoba, Ibiza, Toledo, Arosa, Leon, Altea/Altea XL
- VW** Golf III, Golf III Cabrio, Golf III Estate, Passat, Sharan, Vento, Caddy, Golf IV Cabrio, Polo, Polo Classic, Bora, Golf IV, Golf IV Estate, Lupo, Beetle, Touran, Transporter T5, Golf Plus, Golf V, Golf V Estate, Jetta, Caddy/Caddy Maxi, Tiguan, Eos, Fox

See all engine APPLICATIONS on the THE **TOOL**FINDER™

1.0	1.1	1.2	1.3	1.4	1.5	1.6	1.7	1.8	1.9
2.0	2.1	2.2	2.3	2.4	2.5	2.6	2.7	2.8	2.9
3.0	3.1	3.2	3.3	3.4	3.5	3.6	3.7	3.8	3.9
4.0	4.1	4.2	4.3	4.4	4.5	4.6	4.7	4.8	4.9



**G** TIMING TOOL SET SUITABLE FOR  
VW GROUP



**GO** CODE **704**  
T with 7 pcs.  
kg 2,2 kg

- AUDI** A3, A1
- SKODA** Octavia II, Fabia II, Roomster, Rapid, Yeti, Rapid Spaceback, Yeti Outdoor
- SEAT** Cordoba, Ibiza, Toledo
- VW** Polo, Golf V, Touran, Eos, Golf Plus, Jetta, Passat, Golf V Estate, Tiguan, Golf VI, Golf VI Cabrio, Golf VI Estate, Scirocco



See all engine APPLICATIONS on the THE **TOOL**FINDER™

1.0	1.1	1.2	1.3	1.4	1.5	1.6	1.7	1.8	1.9
2.0	2.1	2.2	2.3	2.4	2.5	2.6	2.7	2.8	2.9
3.0	3.1	3.2	3.3	3.4	3.5	3.6	3.7	3.8	3.9
4.0	4.1	4.2	4.3	4.4	4.5	4.6	4.7	4.8	4.9

**G** TIMING TOOL SET SUITABLE FOR  
VW GROUP



**GO** CODE **784**  
T with 13 pcs.  
kg 1,8 kg

- AUDI** 80, A2, A3, S3, A4, A6, TT
- SKODA** Fabia, Octavia, Octavia II, Superb
- SEAT** Altea, Altea XL, Arosa, Ibiza, Cordoba, Exeo
- VW** Polo, Polo/Classic, Beetle, Caddy, Lupo, Golf, Passat, Touran, Scirocco, Tiguan



See all engine APPLICATIONS on the THE **TOOL**FINDER™

1.0	1.1	1.2	1.3	1.4	1.5	1.6	1.7	1.8	1.9
2.0	2.1	2.2	2.3	2.4	2.5	2.6	2.7	2.8	2.9
3.0	3.1	3.2	3.3	3.4	3.5	3.6	3.7	3.8	3.9
4.0	4.1	4.2	4.3	4.4	4.5	4.6	4.7	4.8	4.9

**G** TIMING TOOL SET SUITABLE FOR  
VW GROUP



**GO** CODE **753**  
T with 4 pcs.  
kg 0,3 kg

- AUDI** A3, A4, A4 quattro, A6, A3 Cabrio, A4 Cabrio
- SKODA** Fabia, Octavia/Octavia Tour, Roomster, Octavia II, Superb II, Fabia II, Superb
- SEAT** Leon, Toledo, Alhambra, Cordoba, Ibiza, Altea/Altea XL
- VW** Bora, Golf IV, Golf IV Estate, Polo, Sharan, Beetle, Touran, Transporter T5, Golf Plus, Golf V, Golf V Estate, Jetta, Caddy/Caddy Maxi, Passat, Tiguan, Eos



See all engine APPLICATIONS on the THE **TOOL**FINDER™

1.0	1.1	1.2	1.3	1.4	1.5	1.6	1.7	1.8	1.9
2.0	2.1	2.2	2.3	2.4	2.5	2.6	2.7	2.8	2.9
3.0	3.1	3.2	3.3	3.4	3.5	3.6	3.7	3.8	3.9
4.0	4.1	4.2	4.3	4.4	4.5	4.6	4.7	4.8	4.9

**G** TIMING TOOL SET SUITABLE FOR  
VW GROUP



**GO** CODE **759**  
T with 3 pcs.  
kg 1,1 kg

<b>AUDI</b>	A3, A1
<b>SKODA</b>	Octavia II, Fabia II, Roomster, Rapid, Yeti, Rapid Spaceback, Yeti Outdoor
<b>SEAT</b>	Cordoba, Ibiza, Toledo
<b>VW</b>	Polo, Golf V, Touran, Eos, Golf Plus, Jetta, Passat, Golf V Estate, Tiguan, Golf VI, Golf VI Cabrio, Golf VI Estate, Scirocco



See all engine APPLICATIONS on the **THE TOOLFINDER™**

1.0	1.1	1.2	1.3	1.4	1.5	1.6	1.7	1.8	1.9
2.0	2.1	2.2	2.3	2.4	2.5	2.6	2.7	2.8	2.9
3.0	3.1	3.2	3.3	3.4	3.5	3.6	3.7	3.8	3.9
4.0	4.1	4.2	4.3	4.4	4.5	4.6	4.7	4.8	4.9

**G** TIMING TOOL SET SUITABLE FOR  
VW GROUP



**GO** CODE **767**  
T with 4 pcs.  
kg 1,2 kg

<b>AUDI</b>	A1, A3, A4, A5, A6, A7, A8, Q3, Q5, TT, Q7, S1, S3
<b>SKODA</b>	Octavia, Superb, Yeti
<b>SEAT</b>	Altea, Exeo, Ibiza, Leon, Toledo
<b>VW</b>	Passat, Scirocco, Sharan, Tiguan, Transporter, Transporter T6, Amarok, Beetle, CC, Eos, Polo, Touran, Golf



See all engine APPLICATIONS on the **THE TOOLFINDER™**

1.0	1.1	1.2	1.3	1.4	1.5	1.6	1.7	1.8	1.9
2.0	2.1	2.2	2.3	2.4	2.5	2.6	2.7	2.8	2.9
3.0	3.1	3.2	3.3	3.4	3.5	3.6	3.7	3.8	3.9
4.0	4.1	4.2	4.3	4.4	4.5	4.6	4.7	4.8	4.9

**G** TIMING TOOL SET SUITABLE FOR  
VW GROUP



**GO** CODE **783**  
T with 18 pcs.  
kg 2,7 kg

<b>AUDI</b>	80, A2, A3, A3 Cabrio, A4, A4 quattro, A5, A5 Coupe/Cabriolet, A6, A6 quattro, TT, Q5
<b>SKODA</b>	Fabia, Fabia II, Felicia, Roomster, Octavia, Octavia Tour, Octavia II, Superb, Superb II
<b>SEAT</b>	Ibiza, Altea, Altea XL, Arosa, Ibiza/Cordoba, Inca, Leon, Toledo, Alhambra, Exeo
<b>VW</b>	Lupo, Polo, Polo/Classic, Fox, Golf/Bora, Golf/Plus, Jetta, Jetta III, Eos, Beetle, New Beetle, Scirocco, Tiguan, Passat, Passat CC, Touran, Sharan, Caddy, Vento, Caddy Maxi, Golf Estate, Sharan, Transporter



See all engine APPLICATIONS on the **THE TOOLFINDER™**

1.0	1.1	1.2	1.3	1.4	1.5	1.6	1.7	1.8	1.9
2.0	2.1	2.2	2.3	2.4	2.5	2.6	2.7	2.8	2.9
3.0	3.1	3.2	3.3	3.4	3.5	3.6	3.7	3.8	3.9
4.0	4.1	4.2	4.3	4.4	4.5	4.6	4.7	4.8	4.9

**G** TIMING TOOL SET SUITABLE FOR  
VW GROUP



**GO** CODE **711**  
T with 5 pcs.  
kg 1,5 kg

<b>SKODA</b>	Citigo, Fabia III, Fabia III Estate
<b>SEAT</b>	Mii, Ibiza
<b>VW</b>	Up!, Polo



See all engine APPLICATIONS on the **THE TOOLFINDER™**

1.0	1.1	1.2	1.3	1.4	1.5	1.6	1.7	1.8	1.9
2.0	2.1	2.2	2.3	2.4	2.5	2.6	2.7	2.8	2.9
3.0	3.1	3.2	3.3	3.4	3.5	3.6	3.7	3.8	3.9
4.0	4.1	4.2	4.3	4.4	4.5	4.6	4.7	4.8	4.9



**G** TIMING TOOL SET SUITABLE FOR  
VW GROUP



**GO** CODE **708**  
T with 6 pcs.  
kg 1,1 kg

- AUDI** A1, A2, A3, A3 Cabrio, A4
- SKODA** Fabia, Roomster, Octavia, Yeti
- SEAT** Alhambra, Cordoba, Ibiza
- VW** Polo, Caddy, Caddy Maxi, Golf, Golf Plus, Golf Estate



See all engine APPLICATIONS on the **THE TOOL FINDER™**

1.0	1.1	1.2	1.3	1.4	1.5	1.6	1.7	1.8	1.9
2.0	2.1	2.2	2.3	2.4	2.5	2.6	2.7	2.8	2.9
3.0	3.1	3.2	3.3	3.4	3.5	3.6	3.7	3.8	3.9
4.0	4.1	4.2	4.3	4.4	4.5	4.6	4.7	4.8	4.9

**G** TIMING TOOL SET SUITABLE FOR  
VW GROUP



**GO** CODE **717**  
T with 10 pcs.  
kg 2,5 kg

- AUDI** A3 Cabrio, A3/A3 Sportback, A4, A4 allroad, A4 quattro, A5 Cabriolet, A5 Coupe, A5 Sportback, A6, Q3, Q5, TT
- SKODA** Octavia II, Superb II
- SEAT** Leon, Altea/Altea XL, Toledo, Alhambra
- VW** Golf VI, Golf VI Cabrio, Golf VI Estate, Jetta, Scirocco, Eos, Passat, Passat Alltrack, Passat CC, Sharan, Tiguan



See all engine APPLICATIONS on the **THE TOOL FINDER™**

1.0	1.1	1.2	1.3	1.4	1.5	1.6	1.7	1.8	1.9
2.0	2.1	2.2	2.3	2.4	2.5	2.6	2.7	2.8	2.9
3.0	3.1	3.2	3.3	3.4	3.5	3.6	3.7	3.8	3.9
4.0	4.1	4.2	4.3	4.4	4.5	4.6	4.7	4.8	4.9

**G** TIMING TOOL SET SUITABLE FOR  
VW GROUP



**GO** CODE **715**  
T with 10 pcs.  
kg 1,5 kg

- AUDI** A3 Cabrio, A3 Saloon, A3 Sedan, A3/A3 Sportback, A4, A4 allroad, A4 quattro, A5 Coupe/Cabriolet, A5 Sportback, A6, Q5, TT
- SKODA** Octavia III
- SEAT** Leon, Leon ST
- VW** Golf SV/Sportsvan, Golf VII, Golf VII Estate, Golf VII Wagon, Polo



See all engine APPLICATIONS on the **THE TOOL FINDER™**

1.0	1.1	1.2	1.3	1.4	1.5	1.6	1.7	1.8	1.9
2.0	2.1	2.2	2.3	2.4	2.5	2.6	2.7	2.8	2.9
3.0	3.1	3.2	3.3	3.4	3.5	3.6	3.7	3.8	3.9
4.0	4.1	4.2	4.3	4.4	4.5	4.6	4.7	4.8	4.9

**G** TIMING TOOL SET SUITABLE FOR  
VW GROUP



**GO** CODE **748**  
T with 4 pcs.  
kg 0,8 kg

- SKODA** Fabia, Roomster
- SEAT** Ibiza, Cordoba
- VW** Fox, Lupo, Polo



See all engine APPLICATIONS on the **THE TOOL FINDER™**

1.0	1.1	1.2	1.3	1.4	1.5	1.6	1.7	1.8	1.9
2.0	2.1	2.2	2.3	2.4	2.5	2.6	2.7	2.8	2.9
3.0	3.1	3.2	3.3	3.4	3.5	3.6	3.7	3.8	3.9
4.0	4.1	4.2	4.3	4.4	4.5	4.6	4.7	4.8	4.9

**G** TIMING TOOL SET SUITABLE FOR  
**VW GROUP**



**GO** CODE **785**  
with 2 pcs.  
0,3 kg

<b>AUDI</b>	A1, A1/A1 Sportback, A3, A3 Cabrio
<b>SKODA</b>	Fabia II, Praktik, Rapid, Rapid Spaceback, Roomster, Octavia II, Yeti, Yeti Outdoor
<b>SEAT</b>	Ibiza, Toledo, Altea/Altea XL, Leon
<b>VW</b>	Caddy/Caddy Maxi, Golf Plus, Golf VI, Golf VI Estate, Polo, Beetle/Maggiolino, Golf VI Cabrio, Jetta, Touran

See all engine APPLICATIONS on the **THE TOOLFINDER™**

1.0	1.1	1.2	1.3	1.4	1.5	1.6	1.7	1.8	1.9
2.0	2.1	2.2	2.3	2.4	2.5	2.6	2.7	2.8	2.9
3.0	3.1	3.2	3.3	3.4	3.5	3.6	3.7	3.8	3.9
4.0	4.1	4.2	4.3	4.4	4.5	4.6	4.7	4.8	4.9

**G** TIMING TOOL SET SUITABLE FOR  
**VW GROUP, FORD**



**GO** CODE **705**  
with 24 pcs.  
5 kg

<b>AUDI</b>	80, A4, A6, Cabriolet, A4 quattro, A6 quattro, A8, A3, Allroad, A2, A4 Cabrio, TT, A3 Cabrio
<b>SKODA</b>	Octavia/Octavia Tour, Fabia, Superb, Roomster, Octavia II, Superb II, Fabia II, Praktik
<b>SEAT</b>	Alhambra, Cordoba, Ibiza, Toledo, Arosa, Leon, Inca, Altea/Altea XL
<b>VW</b>	Golf III, Golf III Cabrio, Golf III Estate, Passat, Sharan, Vento, Polo, Lupo, Caddy, Golf IV Cabrio, Polo Classic, Bora, Golf IV, Golf IV Estate, Polo Estate, Beetle, Fox, Touran, Transporter T5, Golf Plus, Golf V, Golf V Estate, Jetta, Caddy/Caddy Maxi, Tiguan, Eos

See all engine APPLICATIONS on the **THE TOOLFINDER™**

1.0	1.1	1.2	1.3	1.4	1.5	1.6	1.7	1.8	1.9
2.0	2.1	2.2	2.3	2.4	2.5	2.6	2.7	2.8	2.9
3.0	3.1	3.2	3.3	3.4	3.5	3.6	3.7	3.8	3.9
4.0	4.1	4.2	4.3	4.4	4.5	4.6	4.7	4.8	4.9

**G** TIMING TOOL SET SUITABLE FOR  
**VW GROUP**



**GO** CODE **751**  
with 4 pcs.  
0,3 kg

<b>AUDI</b>	A2, A3, A4, A4 quattro, A6, A6 quattro, A3 Cabrio, A4 Cabrio, A4 allroad, A5 Coupe/Cabriolet, A5 Sportback, Q5, A5 Cabriolet, A1, TT, Q3
<b>SKODA</b>	Fabia, Octavia/Octavia Tour, Superb, Roomster, Octavia II, Superb II, Fabia II, Praktik, Rapid, Rapid Spaceback, Yeti, Yeti Outdoor
<b>SEAT</b>	Arosa, Cordoba, Ibiza, Alhambra, Leon, Toledo, Altea/Altea XL, Exeo
<b>VW</b>	Lupo, Polo, Bora, Golf IV, Golf IV Estate, Sharan, Beetle, Passat, Golf Plus, Golf V, Golf V Estate, Jetta, Touran, Caddy/Caddy Maxi, Tiguan, Eos, Fox, Golf VI, Golf VI Estate, Beetle/Maggiolino, Golf VI Cabrio, Passat CC, Scirocco, CC, Passat Alltrack
<b>FORD</b>	Galaxy

See all engine APPLICATIONS on the **THE TOOLFINDER™**

1.0	1.1	1.2	1.3	1.4	1.5	1.6	1.7	1.8	1.9
2.0	2.1	2.2	2.3	2.4	2.5	2.6	2.7	2.8	2.9
3.0	3.1	3.2	3.3	3.4	3.5	3.6	3.7	3.8	3.9
4.0	4.1	4.2	4.3	4.4	4.5	4.6	4.7	4.8	4.9

**G** TIMING TOOL SET SUITABLE FOR  
**VW GROUP**



**GO** CODE **718**  
with 11 pcs.  
2,5 kg

<b>AUDI</b>	A4 Cabrio, A4 quattro, A6 allroad, A6 quattro, A8, A4, A6, Q7, A5 Coupe/Cabriolet
<b>VW</b>	Touareg, Phaeton

See all engine APPLICATIONS on the **THE TOOLFINDER™**

1.0	1.1	1.2	1.3	1.4	1.5	1.6	1.7	1.8	1.9
2.0	2.1	2.2	2.3	2.4	2.5	2.6	2.7	2.8	2.9
3.0	3.1	3.2	3.3	3.4	3.5	3.6	3.7	3.8	3.9
4.0	4.1	4.2	4.3	4.4	4.5	4.6	4.7	4.8	4.9

**G** TIMING TOOL SET SUITABLE FOR  
**VW GROUP**



**GO** CODE **762**  
T with 8 pcs.  
kg 2,05 kg

- AUDI** A1, A1 Sportback, A3 Cabrio, A3 Saloon, A3 Sedan, A3, A3 Sportback, Q2, Q3
- SKODA** Fabia III, Fabia III Estate, Octavia III
- SEAT** Alhambra, Ibiza, Leon, Leon ST, Toledo3
- VW** Beetle, Coccinelle, Maggiolino, Caddy, Caddy Maxi, CC, Golf SV, Golf Sportsvan, Golf VI Cabrio, Golf VII, Golf VII Estate, Golf VII Wagon, Jetta, Passat, Polo, Sharan, Tiguan, Touran



See all engine APPLICATIONS on the **THE TOOLFINDER™**

1.0	1.1	1.2	1.3	1.4	1.5	1.6	1.7	1.8	1.9
2.0	2.1	2.2	2.3	2.4	2.5	2.6	2.7	2.8	2.9
3.0	3.1	3.2	3.3	3.4	3.5	3.6	3.7	3.8	3.9
4.0	4.1	4.2	4.3	4.4	4.5	4.6	4.7	4.8	4.9

**G** TIMING TOOL SET SUITABLE FOR  
**VW GROUP**



**GO** CODE **716**  
T with 9 pcs.  
kg 2,2 kg

- AUDI** A3/A3 Sportback, A4, A4 Cabrio, A4 quattro, A6, S3, TT
- SKODA** Octavia II
- SEAT** Leon, Altea/Altea XL, Toledo, Exeo
- VW** Eos, Golf Plus, Golf V, Golf VI, Golf VI Cabrio, Jetta, Scirocco, Passat, Touran



See all engine APPLICATIONS on the **THE TOOLFINDER™**

1.0	1.1	1.2	1.3	1.4	1.5	1.6	1.7	1.8	1.9
2.0	2.1	2.2	2.3	2.4	2.5	2.6	2.7	2.8	2.9
3.0	3.1	3.2	3.3	3.4	3.5	3.6	3.7	3.8	3.9
4.0	4.1	4.2	4.3	4.4	4.5	4.6	4.7	4.8	4.9

**G** TIMING TOOL SET SUITABLE FOR  
**VW GROUP**



**GO** CODE **714**  
T with 11 pcs.  
kg 2,2 kg

- AUDI** A4, A4 allroad, A4 quattro, A5 Coupe/Cabriolet, A5 Sportback, Q5, A6, A5 Cabriolet, A1, A3, A3 Cabrio, TT, Q3
- SKODA** Fabia II, Praktik, Roomster, Rapid, Rapid Spaceback, Octavia II, Superb II, Yeti, Yeti Outdoor
- SEAT** Exeo, Ibiza, Altea/Altea XL, Leon, Toledo, Alhambra
- VW** Transporter T5, Polo, Golf Plus, Golf VI, Golf VI Estate, Jetta, Touran, Beetle/Maggiolino, Golf VI Cabrio, Passat, Passat CC, Tiguan, Eos, Scirocco, Golf V Estate, CC, Passat Alltrack, Sharan, Caddy/Caddy Maxi



See all engine APPLICATIONS on the **THE TOOLFINDER™**

1.0	1.1	1.2	1.3	1.4	1.5	1.6	1.7	1.8	1.9
2.0	2.1	2.2	2.3	2.4	2.5	2.6	2.7	2.8	2.9
3.0	3.1	3.2	3.3	3.4	3.5	3.6	3.7	3.8	3.9
4.0	4.1	4.2	4.3	4.4	4.5	4.6	4.7	4.8	4.9

the toolmaker  
**GOVONI**<sup>®</sup>  
*...just blue, just perfect!*



# HYDRAULIC CYLINDERS

**CYLINDERS**

**183-188**

**PUMP**

**189-190**

**CONNECTORS**

**191-192**



## 16T MECHADRAULIC-SPINDLE ADAPTOR KIT

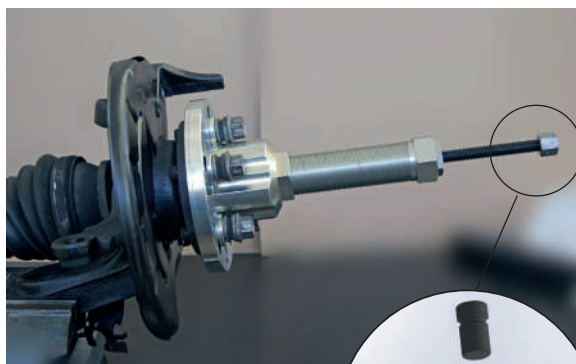

The set includes 5 spare safety pins. The safety pins avoid damaging the tool in case the maximum torque has been reached, pin will break. In this way the tool cannot be damaged



- Due to the mechanical properties, shape and size, the Govoni Mechadraulic-Spindle is optimally suited for use in the automotive sector: removal and installation of wheel hubs, drive shafts, supporting joints, tie rod heads, pitman arms, silent bearings etc.
- The 1-1/2 inch x 16 tpi receiving thread is one of the most commonly used special tool threads.



### INCLUDED:

Lubricating grease to be used with threaded bars, nuts etc...

### Technical data

- Force: 16 ton
- Dimensions: Ø38x225x345 mm
- Driving torque: 38 Nm
- Receiving thread: 1-1/2 inch x 16 tpi
- Stroke: 20 mm
- Weight: 1,7 kg

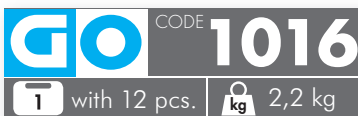

## SET OF PULLERS FOR 16T MECHADRAULIC SCREW

**NEW**



### Components

- 1 x pulling adaptor Ø20
- 1 x pulling adaptor Ø24

- Used in conjunction with the 16 ton mechadraulic screw **GO1016** to extract drive shafts, cv joints and bearings.
- Ideal as a complement to the mechadraulic screw that can be used to prolong the thrust action.

### Application

VAG: e.g. drive shaft made of steel and aluminium, Golf 5 and Golf 6.  
Wheel hubs with small internally splined profile from 21 mm

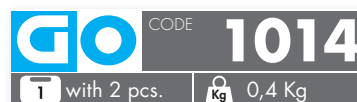



## 12T MECHADRAULIC CYLINDER STEEL

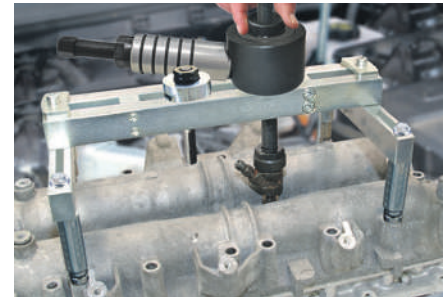

### Technical data

- Hole: Ø21.5 mm
- Stroke: 8 mm
- Dimensions: Ø80x55 mm
- Driving torque: 56 Nm
- Material: aluminium
- Working independent without pump!

**GO** CODE **1010**  
 with 1 pcs. **kg** 2,5 kg



## 12T MECHADRAULIC CYLINDER-SET ALUMINIUM



- Thanks to the use of aluminium, the cylinder combines the strength of steel with the light weight of this element.
- Non-slip grip on the handle.
- There are 4 bores on the body for fastening the cylinder.

### Technical data

- Force: 12 ton
- Stroke: 8 mm
- Dimensions: Ø80x260x45 mm
- Pressure: max. 700 bar
- Hole: Ø21.5 mm
- Driving torque: 56 Nm
- Weight: 1,65 kg
- Grease temperature range of use: from -25°C to 80°C
- Material: aluminium
- Adaptors: M10/M12/M14/M16/M18

### Application

injectors removal; introduction of wheel hubs; general use in the loosening of very tight mechanical components.

**GO** CODE **1015**  
 with 8 pcs. **kg** 1,8 kg  
**§ PATENTED**

## G 12T HYDRAULIC CYLINDER, 8 MM, STEEL



### Technical data

- Dimensions: Ø80x55 mm
- Pressure: max. 700 bar
- Hole: Ø21.5 mm
- Connection: 3/8" -18 NPT

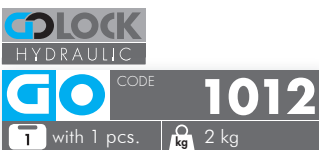

## G 12T HYDRAULIC CYLINDER 43 MM, ALUMINIUM



### Technical data

- Dimensions: Ø90x155 mm
- Pressure: max. 700 bar
- Hole: Ø20 mm
- Connection: 3/8" -18 NPT
- Mounting thread: 2" 3/4-16 UN
- Adaptors: M10/M12/M14/M16/M18

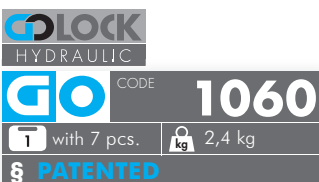

## G 12T HYDRAULIC CYLINDER 8 MM, ALUMINIUM



### Technical data

- Dimensions: Ø80x50 mm
- Pressure: max. 700 bar
- Hole: Ø21.5 mm
- Connection: 3/8" -18 NPT
- Adaptors: M10/M12/M14/M16/M18

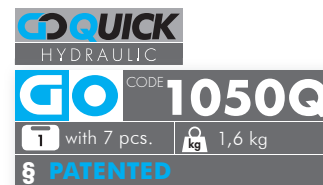
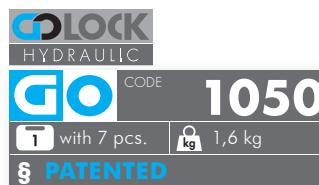

### STROKE

GO1050, GO1050Q

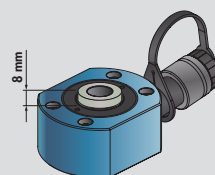

GO1060, GO1060Q, GO1061, GO1061Q

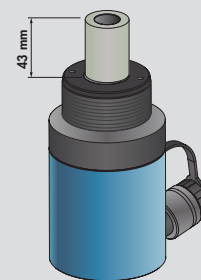

GO1062, GO1062Q

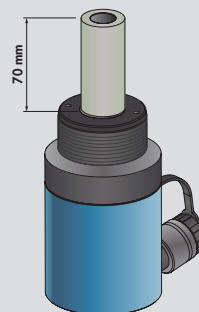

GO1070, GO1070Q

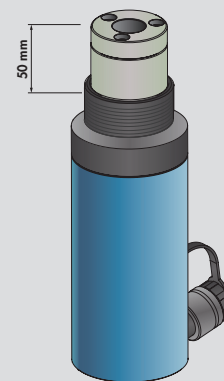



**G 17T HYDRAULIC CYLINDER  
43 MM, STEEL**



**Technical data**

- Dimensions: Ø90x155 mm
- Pressure: max. 700 bar
- Hole: Ø20 mm
- Connection: 3/8" -18 NPT
- Outside connection thread: 2" 3/4-16 UN

**GLOCK**  
HYDRAULIC

**GO** CODE **1017**

with 1 pcs. **kg** 4 kg

**GOQUICK**  
HYDRAULIC

**GO** CODE **1017Q**

with 1 pcs. **kg** 4 kg

**G 17T HYDRAULIC CYLINDER  
43 MM, ALUMINIUM**



**Technical data**

- Dimensions: Ø90x155 mm
- Pressure: max. 700 bar
- Connection: 3/8" -18 NPT
- Outside connection thread: 2" 3/4-16 UN
- Adaptors: M10/M12/M14/M16/M18

**GLOCK**  
HYDRAULIC

**GO** CODE **1061**

with 7 pcs. **kg** 2,2 kg

**§ PATENTED**

**GOQUICK**  
HYDRAULIC

**GO** CODE **1061Q**

with 7 pcs. **kg** 2,2 kg

**§ PATENTED**

**G 17T HYDRAULIC CYLINDER  
70 MM, STEEL**



**Technical data**

- Dimensions: Ø90x155 mm
- Pressure: max. 700 bar
- Hole: Ø20.4 mm
- Connection: 3/8" -18 NPT
- Outside connection thread: 2" 3/4-16 UN

**GLOCK**  
HYDRAULIC

**GO** CODE **1018**

with 1 pcs. **kg** 5,2 kg

**GOQUICK**  
HYDRAULIC

**GO** CODE **1018Q**

with 1 pcs. **kg** 5,2 kg

**G 17T HYDRAULIC CYLINDER  
70 MM, ALUMINIUM**



**Technical data**

- Dimensions: Ø90x155 mm
- Pressure: max. 700 bar
- Hole: Ø20.4 mm
- Connection: 3/8" -18 NPT
- Outside connection thread: 2" 3/4-16 UN
- Adaptors: M10/M12/M14/M16/M18

**GLOCK**  
HYDRAULIC

**GO** CODE **1062**

with 7 pcs. **kg** 2,6 kg

**§ PATENTED**

**GOQUICK**  
HYDRAULIC

**GO** CODE **1062Q**

with 7 pcs. **kg** 2,6 kg

**§ PATENTED**

## G 20T HYDRAULIC CYLINDER 8 MM, STEEL



### Technical data

- Dimensions: Ø100x60 mm
- Pressure: max. 700 bar
- Hole: Ø33 mm
- Connection: 3/8" -18 NPT
- Adapter: Ø20 mm

**GLOCK** HYDRAULIC  
**GO** CODE **1020**  
with 2 pcs. 3 kg

**QUICK** HYDRAULIC  
**GO** CODE **1020Q**  
with 2 pcs. 3 kg

## G 32T HYDRAULIC CYLINDER 50 MM, STEEL



### Technical data

- Dimensions: Ø104x261 mm
- Pressure: max. 700 bar
- Hole: Ø21.5 mm
- Connection: 3/8" -18 NPT
- Inner thread: M24x2
- Outside connection thread: 2" 3/4-16 UN

**GLOCK** HYDRAULIC  
**GO** CODE **1032**  
with 1 pcs. 11,8 kg

**QUICK** HYDRAULIC  
**GO** CODE **1032Q**  
with 1 pcs. 11,8 kg

## G 32T HYDRAULIC CYLINDER 50 MM, ALUMINIUM



### Technical data

- Dimensions: Ø104x261 mm
- Pressure: max. 700 bar
- Hole: Ø21.5 mm
- Connection: 3/8" -18 NPT
- Inner thread: M24x2
- Outside connection thread: 2" 3/4-16 UN

**GLOCK** HYDRAULIC  
**GO** CODE **1070**  
with 1 pcs. 8,6 kg

**QUICK** HYDRAULIC  
**GO** CODE **1070Q**  
with 1 pcs. 8,6 kg

## G SPINDLE M20



### Application

To be used with GO015, GO017

- To be use with the hydraulic cylinders.

**GO** CODE **016**  
with 5 pcs. 1,6 kg

## G SPINDLE M24



### Application

To be used with GO040

- To be use with the hydraulic cylinders.

**GO** CODE **041**  
with 3 pcs. 1,6 kg



# HYDRAULIC ALUMINIUM PUMP - 700BAR HAND OPERATED



**Discharge valve** (hand wheel) enables controlled pressure reduction

- Single-action manual pump, for operating hydraulic cylinders (max 700bar).
- The pump has particularly compact dimensions and an ergonomic design.
- Equipped with a drain valve that allows a controlled pressure reduction in total safety (depressurization).

### Standard equipment

1 x tube: L=1,80 m

1



### Technical data - pump

- Maximum working pressure: 700 bar
- Speed/stroke: single
- Oil tank volume: 700 cm<sup>3</sup>
- Oil volume per stroke: 500 cm<sup>3</sup>
- Oil displacement per stroke: 1.8 cm<sup>3</sup>
- Max effort on the handle to 700 bar: 46 kg
- Piston stroke: 24 mm
- Piston: Ø10 mm
- CE approved machine in compliance with 2006/42/CE (Machine Directive)

### Technical data - hose

- Conductive thermoplastic hose
- Ø9.7 mm
- Connection: 3/8" NPT
- Hose length: 1.8 mt

**GO** CODE **1030**  
1 with 1 pcs. **kg** 4,7 kg

**LOCK** HYDRAULIC  
**SCREW CONNECTION**

**GO** CODE **1030Q**  
1 with 1 pcs. **kg** 4,7 kg

**QUICK** HYDRAULIC  
**QUICK CONNECTION**

Pump side (included)

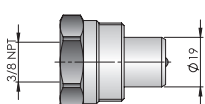

Cylinder side

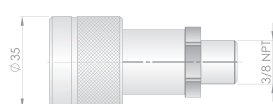

Pump side (included)

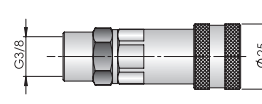

Cylinder side

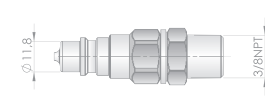



# HYDRAULIC ALUMINIUM PUMP - 700 BAR FOOT PUMP - ALUMINIUM



- The foot-activated pump allows operating on hydraulic cylinders (max 700 bar).
- This allows the mechanic to have both hands free in order to maneuver the equipment / tools.
- The dimensions of the base plate and the pedal ensure stability during the pumping process.
- Equipped with a drain valve, operated with the foot pedal, which allows a controlled pressure reduction in total safety (depressurization).

### Technical data - pump

- Maximum working pressure (1°Speed/stroke): 13.8 bar
- Maximum working pressure (2°Speed/stroke): 700 bar
- Speed/stroke: double
- Oil tank volume: 1400 cm<sup>3</sup>
- Oil volume per stroke: 500 cm<sup>3</sup>
- Oil displacement per stroke (1°speed/stroke): 13 cm<sup>3</sup>
- Oil displacement per stroke (2°speed/stroke): 2.8 cm<sup>3</sup>
- Pump dimensions: 660x174x192 mm

A (mm)	B (mm)	C (mm)	D (mm)	E (mm)
660	174	192	17	461

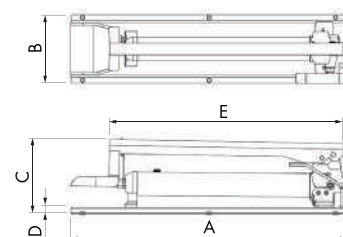

### Technical data - hose

- Conductive thermoplastic hose Ø9.7 mm
- Connection: 3/8" NPT
- Hose length: 1.8 mt

**GO** CODE **1040**  
1 with 1 pcs. 15 kg

**GLOCK**  
HYDRAULIC  
SCREW CONNECTION

**GO** CODE **1040Q**  
1 with 1 pcs. 15 kg

**GO QUICK**  
HYDRAULIC  
QUICK CONNECTION

Pump side (included)

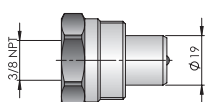

Cylinder side



Pump side (included)

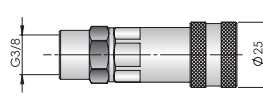

Cylinder side

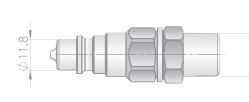





HYDRAULIC QUICK CONNECTOR SET 700 BAR



- The set allows to replace, on the hydraulic pumps on the market, the conventional screw coupling with the convenient quick coupling.

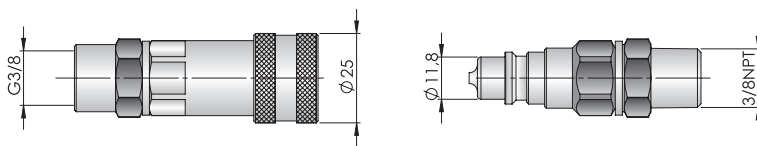

**GO** CODE **1031Q**  
 with 8 pcs. 0,3 kg



SCREW HYDRAULIC CONNECTOR FOR THE PUMP - 700 BAR



- Allows replacement of worn screw couplings.

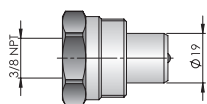

**GO** CODE **1033**  
 with 4 pcs. 0,2 kg

**Application**  
 Suitable for Enerpac, Sun, Celette, Sauer, Pichler, SW-Stahl etc.



QUICK HYDRAULIC CONNECTOR FOR THE PUMP - 700 BAR



- Allows replacement of screw couplings ensuring better handling when coupling and disconnecting hydraulic tools.

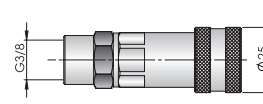

**GO** CODE **1033Q**  
 with 4 pcs. 0,2 kg

**Application**  
 Suitable for Nike, Cejn, Hazet, Walmeck, Vigor etc.

the toolmaker  
**GOVONI**<sup>®</sup>  
*...just blue, just perfect!*

# BODYSHOP

<b>DOORS</b>	<b>193-197</b>
<b>GLASS</b>	<b>198-199</b>
<b>SHEET</b>	<b>200-203</b>
<b>STACKING CABINET FOR GOBOX</b>	<b>204-206</b>

# G UNIVERSAL DOOR ADJUSTING LEVER



- This tool can be used to adjust the doors backlash on cars and vans.
- To align the door lock and to adjust the car door, the operator, through special pins provided, has to position the tool on the latch and, at the same time, on the car door cavity.
- The pins can be fastened and easily replaced, depending on the situation.

## STANDARD VERSION

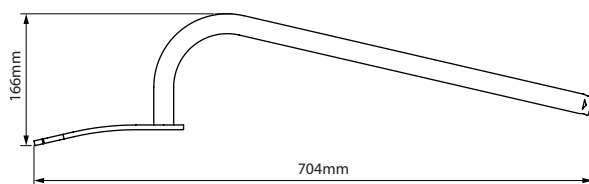

## LONG VERSION

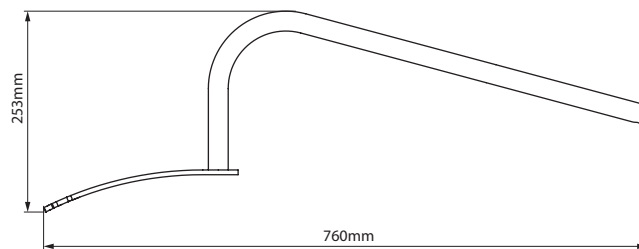

- ✓ Extended base plate for vehicles with a wider door leaf.
- ✓ More pronounced curvature of the handle tube for vehicles that have greater depth and a large overlap between the frame and plastics, in the external paneling of the leaf (e.g. SUV rear doors)

**GO** CODE **1176**  
 1 with 6 pcs. 1,5 kg

**GO** CODE **1177**  
 1 with 6 pcs. 1,6 kg



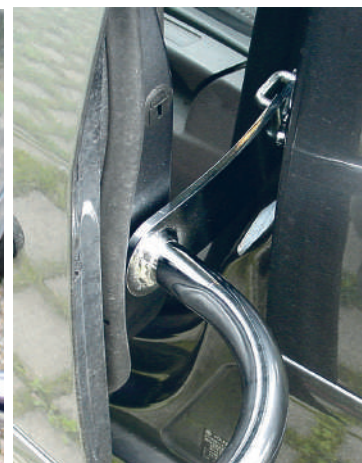

The tool is equipped with 5 special pins, stowed inside the handle, with different lengths and diameters.

PINS DIMENSION

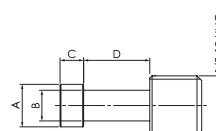

A (mm)	B (mm)	C (mm)	D (mm)
9	6,5	5	14
9	6	5	19
9	6,5	5	27
12	9,5	5	14
17,7	12,5	4,5	17

# G UNIVERSAL DOOR-OPENER TOOL



- The door-opener tool is a practical and useful accessory in bodyworks repair. The tool is equipped with 2 flat hooks, allowing the operator to use them even in narrow spaces. The side of the tool with round narrowing can be insert below the car doors or used on bolts.
- This tool can be paired with our slide hammer **GO438** or with others light chain hoists. In the middle of the tool there is a grip for slide hammer double hook **GO526**.



A (mm)	B (mm)	C (mm)
5	20	130
13,5	15	
10	12	

**GO** CODE **1175**  
 1 with 1 pcs.    kg 0,3 kg



## CLIP SPREADER PLIERS SET



### Application

Fiat, Ford, Nissan, Infiniti, Toyota, Opel/  
GM, Chrysler etc.

- These pliers enable the gentle disassembly of plastic clip rivets as well as clips on automotive cladding parts.
- As soon as the spreader is pulled, the rivets and clips can be removed without any problems and without damage and re-inserted later.
- The pliers are self-opening, which ensures optimal handling.

### Components

3 x pliers with 3 different gripper designs T-Type Rivets (Nissan, Infiniti etc.)

### Example of the clip rivets



GO1191

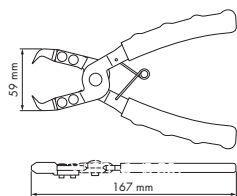

GO1192

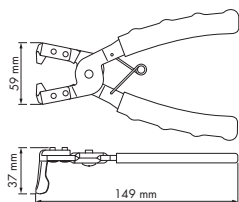

GO1193

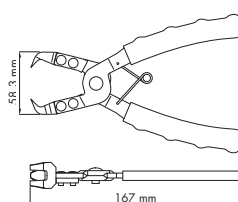

**GO** CODE **1190**  
1 with 3 pcs. 0,7 kg

CODE	TYPE	TECHNICAL SPECIFICATIONS			CLIP RIVETS MODEL
		angle	gripper	weight (kg)	
GO1191	1	0°	2	0,2	
GO1192	2	90°	2	0,2	
GO1193	3	0°	3	0,2	

**GO** CODE **1191**  
1 with 1 pcs. 0,2 kg

**GO** CODE **1192**  
1 with 1 pcs. 0,2 kg

**GO** CODE **1193**  
1 with 1 pcs. 0,2 kg



## UNIVERSAL DOOR OPENING LEVER KIT



- With the help of the plastic lever, the vehicle door is levered open until there is enough space for the use of an expanding cushion. Due to the convex back of the tool (rubber) it can be handled with one hand while holding the spreading cushion with the other hand is placed. Moreover, the contact surface on the vehicle is not damaged.
- The levers are made of high-strength polycarbonate plastic on both sides e.g. can also be used as a wedge.

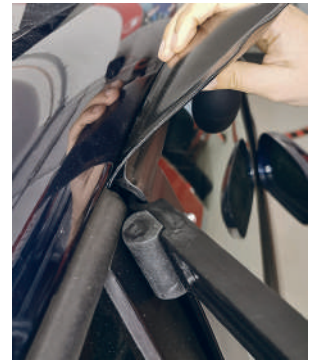

### Standard equipment

- 1 x door opening lever, wedge shape, L = 225 x 35 mm
- 1 x door opening lever, round shape, L = 250 x 35 mm

1  
2



**GO** CODE **1195**  
 with 2 pcs. **kg** 0,3 kg



## FIXING FOR ENGINE AND TRUNK STAND

Ø **10,2** UNIVERSAL - ALUMINIUM

- Suitable for fixing engine and trunk stands when the gas spring is defective.
- Aluminum body and locking screw with scratch-resistant brass bushing



### Technical data

- Fixing Ø max. 10.2 mm

**GO** CODE **1178**  
 with 1 pcs. **kg** 0,1 kg



## FIXING FOR ENGINE AND TRUNK STAND

Ø **13** UNIVERSAL - ALUMINIUM

- Suitable for fixing engine and trunk stands when the gas spring is defective.
- Aluminum body and locking screw with scratch-resistant brass bushing



### Technical data

- Fixing Ø max. 13 mm

**GO** CODE **1179**  
 with 1 pcs. **kg** 0,1 kg







## UNIVERSAL WIPER ARM EXTRACTOR



### Components

- 8 x fork puller
- 1 x wiper arm extractor, fork width 15 mm (to be used like OE T10369/1)
- 1 x wiper arm extractor, fork width 24 mm (to be used like OE T10369/2)
- 1 x wiper arm extractor, fork width 15 mm (to be used like OE T10369/3)
- 1 x wiper arm extractor, fork width 26.6 mm (to be used like OE T10369/4)
- 1 x nozzle cleaning and adjustment pin

### Application

VW, Audi, Seat, Skoda, Opel Honda, BMW, Mercedes Benz, Peugeot, Citroën, Renault, Volvo Nissan, Saab, Fiat, Ford, Alfa Romeo, Lancia etc.

- Kit designed to extract wiper arms.
- Pressure spindle or slide hammer can be used in combination with this kit.
- Ideal for wipers with nozzle located in the middle of the arm.
- Compatible with 450 wiper arms, 300 vehicles and 30 different car brands.

**GO** CODE **1152**  
 with 17 pcs. 5,6 kg



## UNIVERSAL WIPER ARM EXTRACTOR



TYPE	A (mm)	B (mm)	C (mm)	D (mm)
1	2,5	5	8	26,5
2	2,5	3	6	15

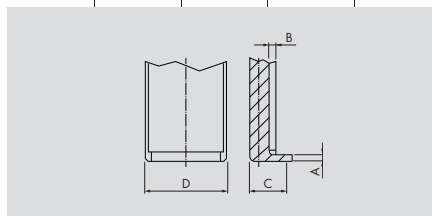

- Universal 2-arm extractor with two arm pairs.

Include two different pairs of arms



**GO** CODE **1153**  
 with 1 pcs. 0,7 kg



# G LOCKING WIPER PULLER WITH SLIDE HAMMER

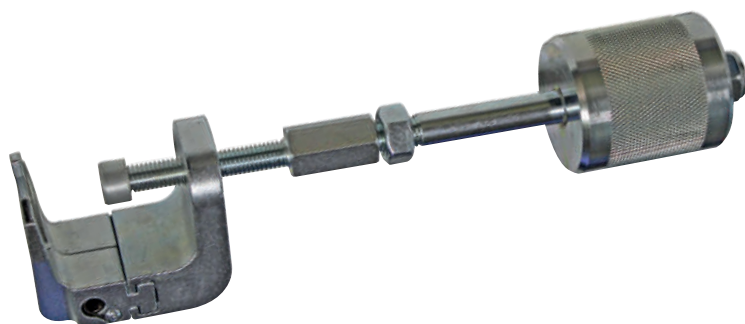

**Technical data**

- Adjustable fork width (spring mechanism)
- Screw: M10x1
- Connection: SW 17 mm
- Fork width: 16 - 38 mm
- Working height: 48 mm
- Weight: 0,5 kg



- Required to remove the wiper arm from the wiper arm shaft.
- The special design with infinitely adjustable fork width (spring mechanism) and the narrow fork ensure high model coverage and good access even in confined spaces.

**NEW:**

in addition to the normal pressure spindle, loosening is also possible using a slide hammer. This is important, for example, for versions where the washer nozzle is in the hollow shaft of the wiper arm and therefore there is no direct contact with the water. It is not possible to exert direct pressure on the wiper arm shaft.

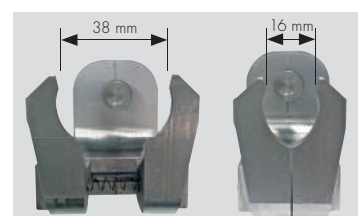

**GO** CODE **1127**  
 with 6 pcs.      kg 1,52 kg

# G UNIVERSAL WIPER EXTRACTOR WITH ADJUSTABLE FORK

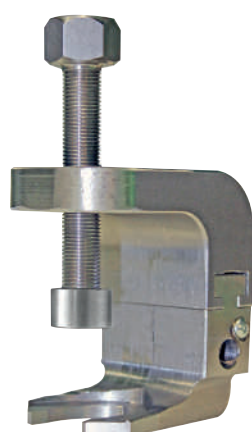

- Extractor for removing the wiper arm from the wiper shaft.
- Special version with adjustable fork spring controlled.
- Extraction spindle with turning head made of aluminium to prevent damage to shaft.
- The ultra-thin fork design allows the usage in very narrow spaces.
- Money saving - replacing countless other extractor tools!

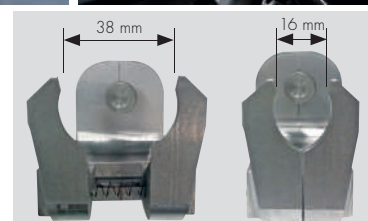

**GO** CODE **1151**  
 with 1 pcs.      kg 0,6 kg

**Technical data**

- Screw: M10x1
- Connection: SW 17 mm
- Fork width: 16 - 38 mm
- Working height: 48 mm
- Weight: 0,5 kg



## TOOLS FOR LIFTING AND REMOVING EXTERNAL AND INTERNAL CLADDINGS

**NEW**



- Set for removing exterior and interior trim, moldings, dashboards, door panels and clips
- Peculiarity of the tool, it is composed of a wedge, a lever and grooves of two sizes: 5mm and 7.5mm
- Made of unbreakable special steel.



**GO** CODE **1174**  
 with 2 pcs. 0,27 Kg



## METAL WEDGE TOOLS

**NEW**

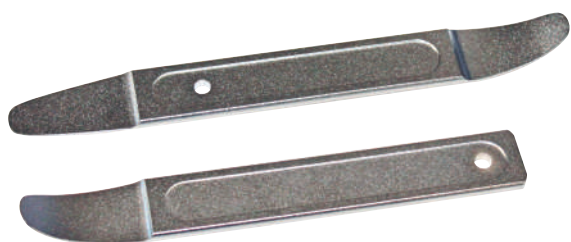

- The metal wedge is the tool to use (instead of the screwdriver!) when it is necessary to lever and move the ends of the sheet metal casing. Simply insert the thin curved blade into the slot and slide it along the edge to gently separate the car metal sheets components without causing marks and scratches
- Made of unbreakable special steel



**GO** CODE **1199**  
 with 2 pcs. 0,28 Kg



**SLIDE HAMMER - 9 KG**



- For powerfully releasing components and for bodywork straightening jobs.
- Extremely effective loosening effect via impact with a maximum force of approx. 8 ton.
- It loosens even the most firmly seized or rusty components, or connected with a cone.
- With the relevant accessories, suitable for removing injectors, wheel hubs, supporting joints etc.



**GO** CODE **520**  
 T with 1 pcs. kg 11,6 kg

**Technical data**

- Slide hammer with weight: 9 kg
- Total length: 770 mm
- Connection thread: M18x1.5



**SLIDING HAMMER 9KG, DEAD BLOW**

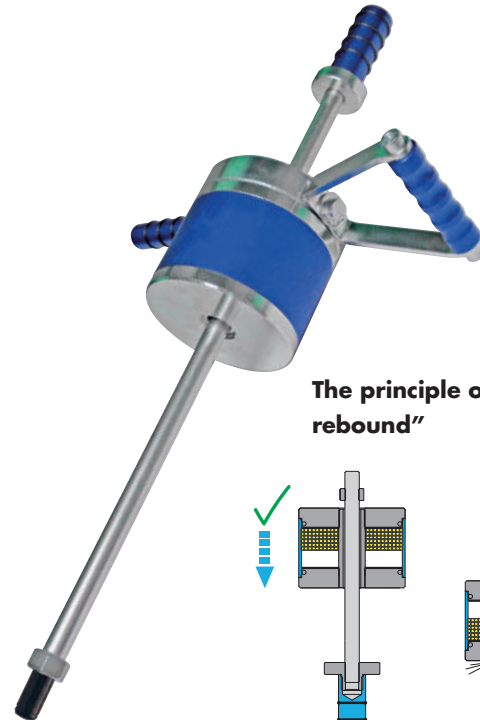

**The principle of "no-rebound"**

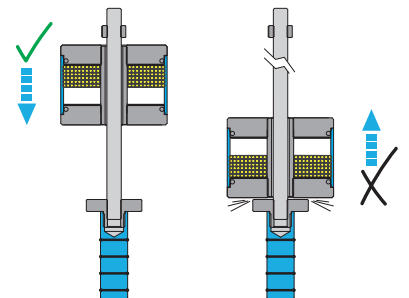

- For powerful expulsion of stuck components as well as for body straightening work.
- The new slide hammer version is filled with a steel shot. This prevents the weight from bouncing back against the abutment. The impact intensity is thus increased because the full impact force is transmitted to the component to be machined.
- This version is also very gentle on the joints and allows fatigue-free working.



**GO** CODE **530**  
 T with 2 pcs. kg 11 kg  
 § **PATENTED**



**G** PULL/HANGER HOOK,  
 EXTRA LARGE **UNIVERSAL**



**Technical data**

- Connecting thread: M18x1.5
- Height inside: 110 mm
- Hook width: 40 mm
- Total weight: 2,34 kg

**Application**

Universal, e.g. Ford Mondeo, MB Vito front axle

**GO** CODE **528**  
 1 with 1 pcs. **kg** 2,5 kg

**G** DOUBLE HOOK FOR SLIDE  
 HAMMER **UNIVERSAL**



**Technical data**

- Length: 117 mm
- Max. width: 53 mm
- Hook distance: 15 mm
- Triangle bore: 13 mm
- Triangle opening: 17 mm

**Application photo**

**GO** CODE **526**  
 1 with 1 pcs. **kg** 0,8 kg

**G** UNIVERSAL BODY PULL  
 CLAMP "MINI", FOR 2 PULL  
 DIRECTIONS



**Extra slim and small version.**  
**For slide hammer or chain.**

**Technical data**

- Traction: straight max. 3.000 kg/sideward max. 2.000 kg
- Mouth width: 36 mm
- Clamping depth: 10 mm
- Length: 150 mm



**GO** CODE **1145**  
 1 with 1 pcs. **kg** 1,2 kg

**G** UNIVERSAL BODY  
 TENSION CLAMP 90°  
 ANGLED



**Technical data**

- Traction: 2.000 kg
- Mouth width: 40 mm
- Clamping depth: 28 mm
- Length: 165 mm



**GO** CODE **1146**  
 1 with 1 pcs. **kg** 1,4 kg



**G** UNIVERSAL BODY PULL CLAMP "BASIC", FOR 2 PULL DIRECTIONS



2 traction directions

**Technical data**

- Traction: straight max. 5.000 kg/ sideward max. 2.000 kg
- Mouth width: 43 mm
- Clamping depth: 30 mm
- Length: 220 mm



**GO** CODE **1147**  
 1 with 1 pcs. **kg** 2,3 kg

**G** UNIVERSAL BODY PULL CLAMP "BOX", FOR 2 PULL DIRECTIONS



2 traction directions

**Technical data**

- Traction: straight max. 3.000 kg/ sideward max. 2.000 kg
- Mouth width: 35 mm
- Clamping depth: 60 mm
- Length: 245 mm



**GO** CODE **1148**  
 1 with 1 pcs. **kg** 2,3 kg

**G** UNIVERSAL BODY PULL CLAMP

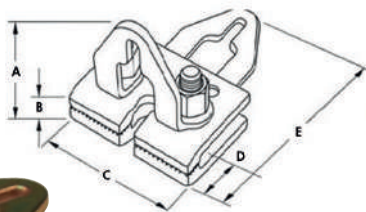
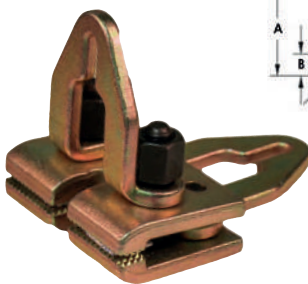

**Technical data**

- A = 140 mm
- B = 22 - 135 mm
- C = 120 mm
- D = 32 mm
- E = 175 mm

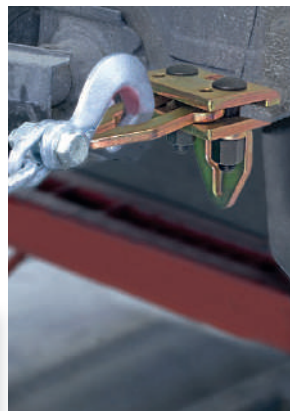

**GO** CODE **1155**  
 1 with 1 pcs. **kg** 2,9 kg



## SYSTEM STACKING CABINET FOR GOBOX SMART CASE



### Notice

- Supplied without case

### GOBOX case technical data Model 1

- Width: 500 mm
- Depth: 380 mm
- **Height: 85 mm**
- Material: ABS
- Product weight: 2.354 g



### GOBOX case technical data Model 2

- Width: 500 mm
- Depth: 380 mm
- **Height: 140 mm**
- Material: ABS
- Product weight: 2.822 g



### GOBOX case technical data Model 3

- Width: 370 mm
- Depth: 270 mm
- **Height: 85 mm**
- Material: ABS
- Product weight: 1.360 g



- Organisation system consisting of stackable modules for 3 or 5 GOBOX system cases that can also be screwed into each other.
- Ball-bearing-mounted telescopic extensions.
- Side panels and rear panel with square perforation.
- Central locking with two keys.

**GO** CODE **1401** **5 DRAWERS**  
 with 1 pcs. 22 kg

**Application**

- Stackable modules for nr.5 GOBOX System cases **H=85 mm**  
 Model **1**



**Cabinet technical data**

- Width x depth x height:  
580x455x490 mm
- Load per tray: 20 kg
- Colour: graphite black (RAL 9011)
- Material: Sheet steel Powder-coated

**GO** CODE **1402** **3 DRAWERS**  
 with 1 pcs. 18,5 kg

**Application**

- Stackable modules for nr.3 GOBOX System cases **H=140 mm**  
 Model **2**



**Cabinet technical data**

- Width x depth x height:  
580x455x490 mm
- Load per tray: 20 kg
- Colour: graphite black (RAL 9011)
- Material: Sheet steel Powder-coated

**GO** CODE **1403** **5 DRAWERS**  
 with 1 pcs. 22 kg

**Application**

- Stackable modules for nr.5 GOBOX System cases **H=85 mm**  
 Model **3**



**Cabinet technical data**

- Width x depth x height:  
455x290x490 mm
- Load per tray: 20 kg
- Colour: graphite black (RAL 9011)
- Material: Sheet steel Powder-coated







video online





# TRUCK

**SILENT BLOCKS**

**207-209**

**HUBS**

**210-215**

**ENGINE**

**216-218**

**BRAKES**

**219-221**

## **G** HGV SPLIT BUSH MASTER KIT WITH 17T HYDRAULIC CYLINDER



**GO1061 Hydraulic cylinder - included**



**INCLUDED:**

Lubricating grease to be used with threaded bars, nuts etc...



**INCLUDED:**

Hydraulic cylinder 17 ton

- Use this tool kit to remove and refit slotted bushes properly. The slight conical grinding makes it possible to extract and reuse bushes without damage.
- The tools may be fit directly on the vehicle without removing entire axes components. Pressers may also be used on the workshop press.
- By means of the locking device and relating half-shells, bushes are pre-tensioned carefully and parallel to one another so they can be pressed easily into their seat. While the bush is often damaged using commercial tapered sockets, the assembly operations do not damage/deform/detach the bearing's cover when this locking device system is used.
- The half-shells are fixed securely inside the locking device so they will not slip out.
- The kit includes a wide selection of the most common applications with high market coverage.
- Included the 17-ton hydraulic cylinder.

Internal diameter	Application
Ø75 mm	MB Actros (stabilizer)
Ø70 mm	MAN
Ø68 mm	MAN (front spring) ROR, SAF
Ø66 mm	IVECO Eurostar (driver's cabin)
Ø65 mm	MB Actros (stabilizzatore), Atego
Ø63 mm	DAF
Ø60 mm	MB/IVECO Eurostar (stabilizer), Renault Kerax, Magnum, Premium
Ø58 mm	MB 3229 B, 652, 650 / Volvo
Ø56 mm	IVECO Eurostar (driver's cabin)

**GO** CODE **1355**  
with 39 pcs. **kg** 23 kg

**Example of application**



Application with hydraulic cylinder

Removal



Assembly

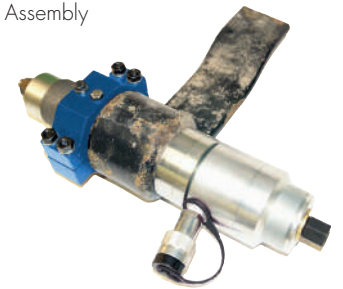

**Technical data hydraulic cylinder**

- Force: 17tons
- Stroke: 43 mm
- Dimensions: Ø90x155 mm
- Pressure: max. 700 bar
- Hole: Ø20.4 mm
- Connection: 3/8" -18 NPT
- Outside connection thread: 2" 3/4-16 UN
- Material: aluminium

**G WRENCH FOR HUBS**



**Technical data**

- 6-teeth
- tooth width 7,5 mm
- Ø Inner 63 mm - 1/2"

**Application**

Mercedes: Sprinter  
Models: HL0/3, HL0/6, HL0/7, HL1/2, HL1/3, HL1/8, HL1/9, HL2/2, HL2/3, HL2/5 HL2/9, HL2/11, HL2/12, HL2/15

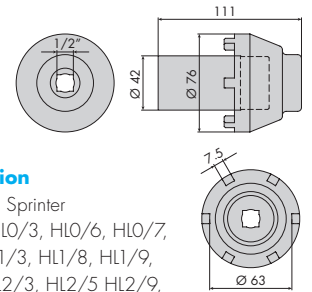

**GO** CODE **1354**  
T with 1 pcs. kg 3,5 kg

**G HGV SPLIT BUSH KIT**



- Use this tool kit to remove and refit slotted bushes **1** properly. The slight conical grinding makes it possible to extract and reuse bushes without damage.
- By means of the locking device and relating half-shells, bushes are pre-tensioned carefully and parallel to one another so they can be pressed easily into their seat.
- **The kit does not include the hydraulic cylinder.**



**GO** CODE **1310**  
T with 39 pcs. kg 21,7 kg

## WRENCH FOR HUBS MERCEDES

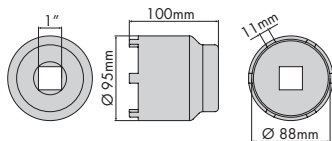

### Technical data

- 6-teeth - tooth width 11 mm
- Inner Ø88 mm - □ 1"

### Application

Rear axle models: VARIO 814 - SPRINTER  
616 - ATEGO HL2/43 DG 6.2

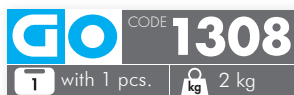

## WRENCH FOR HUBS MERCEDES

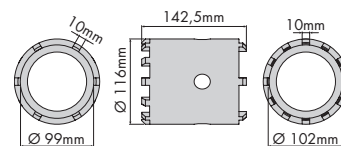

### Technical data

- 12-teeth - tooth width 10 mm - Inner Ø102 mm
- 6-teeth - tooth width 10 mm - Inner Ø99 mm

### Application

Rear axle models: 10TN/13TN, HL7/1, HL7/2, HL7/18, HO7/8, HO7/9, HL7/0, HL7/015, HL/021, HL7/3, HD7/2, HD7/19DG, HD7/016DG  
Front axle models: 7TN AL7/1



## WRENCH FOR HUBS MERCEDES

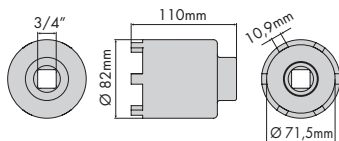

### Technical data

- 6-teeth - tooth width 10,9 mm
- Inner Ø71.5 mm - □ 3/4"

### Application

Rear axle models: HL2/2, HL2/7, HL2/13



## WRENCH FOR HUBS MERCEDES

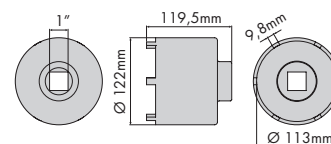
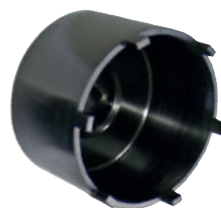

### Technical data

- 6-teeth - tooth width 9,8 mm
- Inner Ø113 mm - □ 1"

### Application

Axle models: NS4/2 - NS4/10  
Sprocket axle models: HL6/1, HL6/2, HL6/3, HD6/3



## WRENCH FOR HUBS MERCEDES

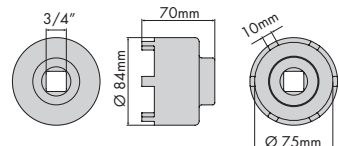

### Technical data

- 6-teeth - tooth width 10 mm
- Inner Ø75 mm - □ 3/4"

### Application

Rear axle models:  
HL2/14, HL2/30, KL2/16, KL4/1, KL4/16, KL4/17, KL4/23, KL4/28, KL4/29, KL4/4, KL4/8, KD4/6G, HO4/2, HO4/18, NR4/4  
Front axle models:  
AL3/1, AL3/2, AL3/3, AL3/4, AL3/7, AL3/8

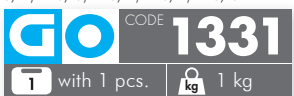

## WRENCH FOR HUBS MERCEDES

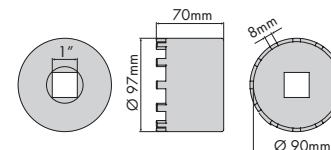

### Technical data

- 12-teeth - tooth width 8 mm
- Inner Ø90 mm - □ 1"

### Application

BRG year 2001  
Suitable for MERCEDES ACTROS 1840





## WRENCH FOR HUBS MERCEDES

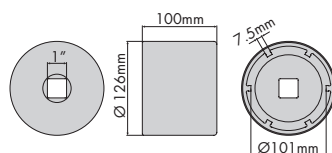

### Technical data

- 6-teeth - tooth width 7.5 mm
- Inner  $\varnothing$ 101 mm -  $\square$  1"

### Application

Suitable for MERCEDES ATEGO

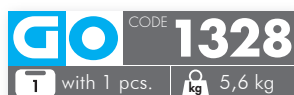

## HEXAGONAL WRENCH FOR HUBS MERCEDES

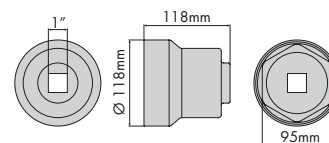

### Technical data

- Hexagonal nut 95 mm -  $\square$  1"

### Application

Rear axle  
Trailer axle  
Axle with compact bearings



## WRENCH FOR HUBS MERCEDES

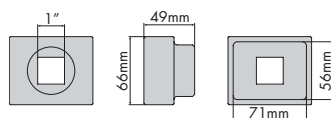

### Application

Axle models KÄSSBOHRER/SETRA: front axle 6,5 and 7,5t of type S 210 and 215, SG 219-221 and dead axle types S 216 HDS and S 228 DT types 0303, 0305-G and 0307

Axle models DAF, Mercedes: VL 3/8, 4/7, 4/9, 4/15, VD 4/14, of type 363, 385, 387, 389, 391, 393, 395, 617, 620, 621, 622, 623, 625, 649

Axle models Mercedes - Bus:

VO 3/10, 4/11, 4/13 and 4/19 of type 0303, 0305-G and 0307

### Technical data

- 56x71 mm -  $\square$  1"

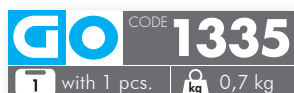

## WRENCH FOR HUBS MERCEDES, MAN

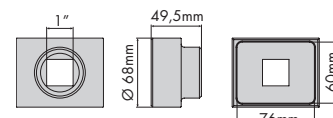

### Application

Front axle models:  
SK VL5/1 D9-2629 in 6x4.  
2635 in 6x4.  
3535K 8x4

Suitable for MERCEDES, MAN

### Technical data

- 60x76 mm -  $\square$  1"



## WRENCH FOR HUBS MERCEDES, MAN, TGA

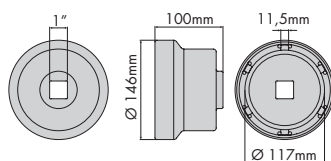

### Technical data

- 6-teeth - tooth width 11.5 mm
- Inner  $\varnothing$ 117 mm -  $\square$  1"

### Application

Rear axle models: TGA  
Suitable for MERCEDES, MAN

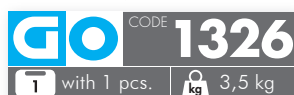

## WRENCH FOR HUBS MAN, TGA

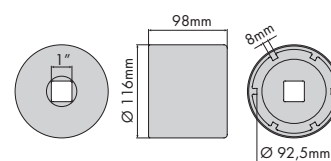

### Technical data

- 6-teeth - tooth width 8 mm
- Inner  $\varnothing$ 92.5 mm -  $\square$  1"

### Application

Front axle models: TGA V9 - 82L - 01  
Suitable for MAN



## G WRENCH FOR HUBS MAN

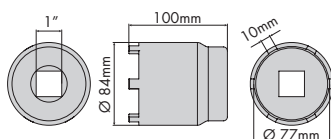

### Technical data

- 6-teeth - tooth width 10 mm
- Inner Ø77 mm - □ 1"

### Application

Front axle models: VW2 - VW4 - VW6.1 - 6.8  
Suitable for MAN

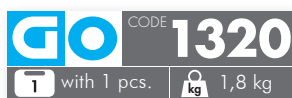

## G WRENCH FOR HUBS MAN

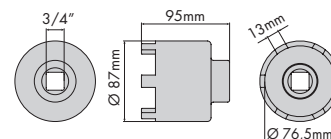

### Technical data

- 6-teeth - tooth width 13 mm
- Inner Ø76.5 mm - □ 3/4"

### Application

Front axle models: M3 - ME - MI  
Rear axle models with outer planetary unit: 3MR - 5MR  
Suitable for MAN



## G WRENCH FOR HUBS MAN

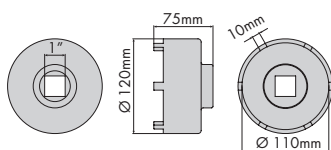

### Technical data

- 6-teeth - tooth width 10 mm
- Inner Ø110 mm - □ 1"

### Application

Low-platform bus with gantry axle HDNP-1300  
Suitable for MAN AUTOBUS

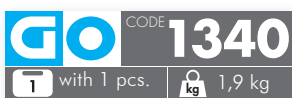

## G HEXAGONAL WRENCH FOR HUBS FRUEHAUF

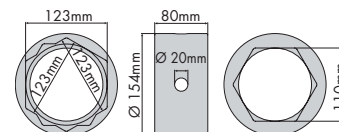

### Technical data

- Ø123 mm
- Hexagon 110 mm

### Application

Suitable for FRUEHAUF



## G WRENCH FOR HUBS BPW

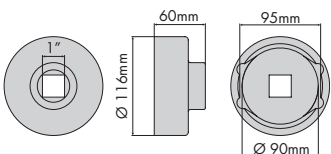

### Technical data

- Inner Ø90 mm - □ 1"

### Application

Suitable for BPW 9TN

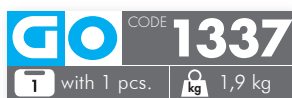

## G WRENCH FOR HUBS BPW

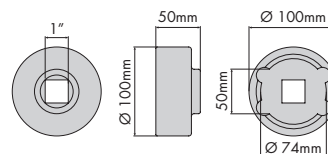

### Technical data

- Inner Ø74 mm - □ 1"

### Application

Suitable for BPW 12TN



## POLYGONAL WRENCH FOR HUBS R.O.R.

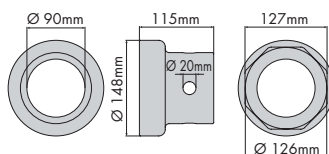

### Technical data

- Octagon 127 mm
- $\varnothing$ 126 mm

### Application

Suitable for R.O.R.



## POLYGONAL WRENCH FOR HUBS R.O.R.

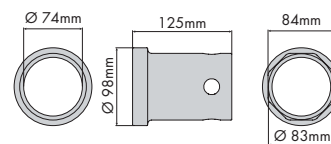

### Technical data

- Octagon 84 mm
- $\varnothing$ int. 83 mm

### Application

Suitable for R.O.R.



## POLYGONAL WRENCH FOR HUBS IVECO

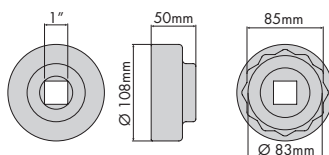
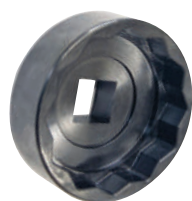

### Technical data

- Polygon 85 mm
- Inner  $\varnothing$ 83 mm -  $\square$  1"

### Application

Suitable for IVECO

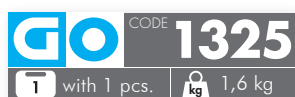

## WRENCH FOR HUBS IVECO

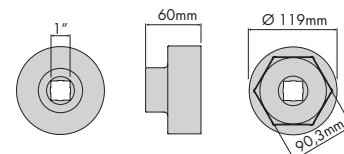
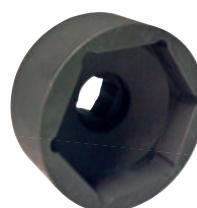

### Technical data

- CH. 90.3 mm -  $\square$  1"

### Application

Suitable for IVECO

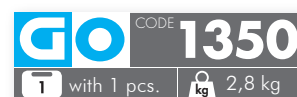

## WRENCH FOR HUBS VOLVO, RENAULT, FIAT

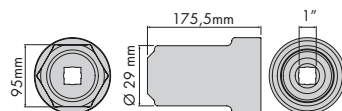

### Technical data

- CH 95 mm - depth 28 mm -  $\square$  1"

### Application

Suitable for RENAULT, VOLVO, FIAT

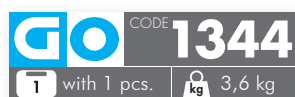

## WRENCH FOR HUBS VOLVO, RENAULT, FIAT, DAF

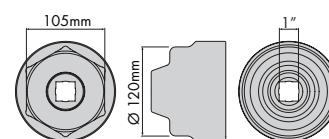

### Technical data

- CH 105.4 mm - depth 38 mm -  $\square$  1"

### Application

Suitable for RENAULT, VOLVO, FIAT, DAF

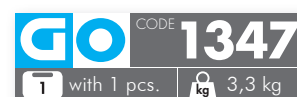

## G WRENCH FOR HUBS RENAULT

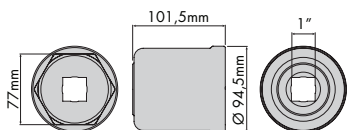

**Technical data**  
• CH 77 mm - □ 1"

**Application**  
Suitable for RENAULT

**GO** CODE **1341**  
T with 1 pcs. kg 1,6 kg

## G WRENCH FOR HUBS RENAULT

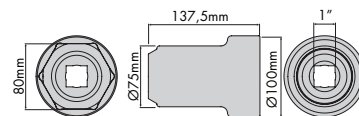

**Technical data**  
• CH 80 mm -  
depth 23 mm - □ 1"

**Application**  
Suitable for RENAULT BUS,  
EUROCARGO, EUROTECH

**GO** CODE **1342**  
T with 1 pcs. kg 2,2 kg

## G WRENCH FOR HUBS RENAULT

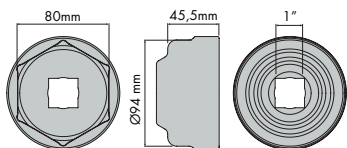

**Technical data**  
• CH 80 mm -  
depth 16 mm - □ 1"

**Application**  
Suitable for RENAULT

**GO** CODE **1343**  
T with 1 pcs. kg 1,2 kg

## G WRENCH FOR HUBS RENAULT

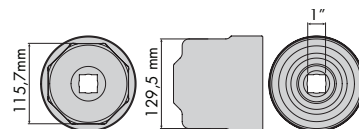

**Technical data**  
• Octagon 115.7 mm -  
depth 45 mm - □ 1"

**Application**  
Suitable for RENAULT

**GO** CODE **1345**  
T with 1 pcs. kg 3,6 kg

## G WRENCH FOR HUBS RENAULT

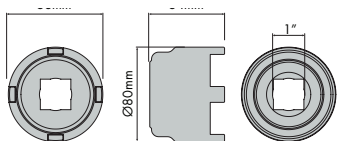

**Technical data**  
• 4-teeth - tooth width  
13.5 mm - □ 1"

**Application**  
Suitable for RENAULT

**GO** CODE **1346**  
T with 1 pcs. kg 1,1 kg

## G WRENCH FOR HUBS RENAULT

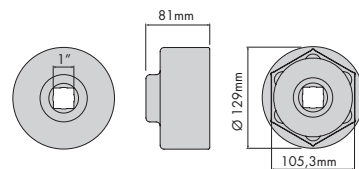

**Technical data**  
• CH 105 mm - □ 1"

**Application**  
Suitable for IRISBUS, VOLVO

**GO** CODE **1349**  
T with 1 pcs. kg 3,5 kg



## G WRENCH FOR HUBS SCANIA

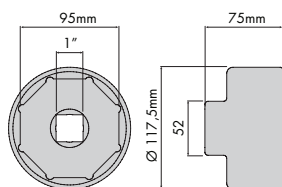

### Technical data

- CH 95 mm - □ 1"
- Octagon 65 mm

### Application

Suitable for SCANIA

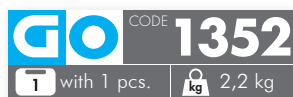

## G HEXAGONAL WRENCH FOR HUB RENAULT

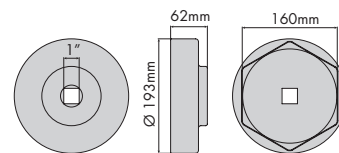

### Technical data

- CH 160 mm - □ 1"

### Application

Suitable for FONTENAC RENAULT



## G HEXAGONAL WRENCH FOR HUB S.A.F.

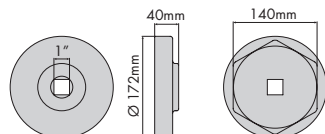

### Technical data

- CH 140 mm - □ 1"

### Application

Suitable for S.A.F.

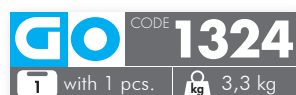

## G WRENCH FOR HUBS SCANIA NEW

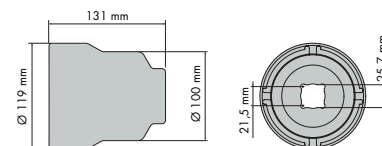

### Technical data

- 4-teeth - tooth width 8mm - inner Ø of the teeth 91mm

### Application

Suitable for SCANIA models rear axle



## G WRENCH FOR HUBS SCANIA

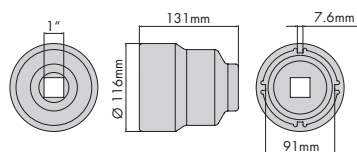

### Technical data

- 4-teeth - tooth width 7,6 mm
- Inner Ø91 mm - □ 1"

### Application

Rear axle  
Suitable for SCANIA

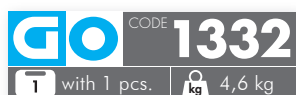

## G WRENCH FOR HUBS SCANIA

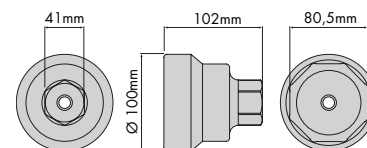

### Technical data

- CH 41 mm
- Octagonal 80,5mm

### Application

Suitable for SCANIA



## FLYWHEEL ROTATION TOOL IVECO

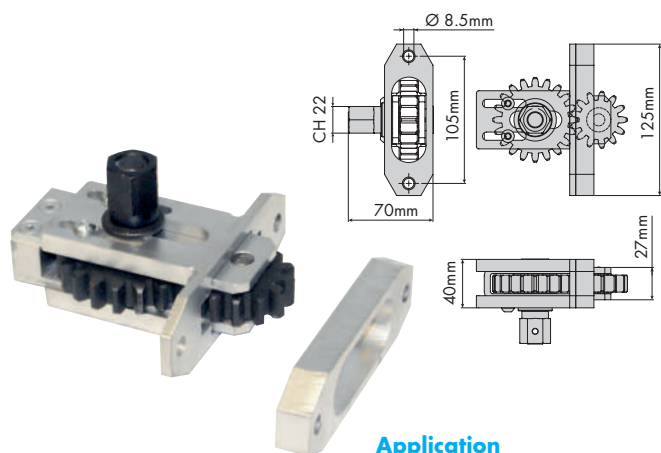

### Application

Euro Cargo, Cargo 150E27R  
PR, FPR 320E27T, PT Eurotech,  
Eurostar  
Engine code: 8360.46, F3A, F3B

**GO** CODE **1300**  
1 with 2 pcs. 1,9 kg

### Technical data

- 2 gears

## FLYWHEEL ROTATION TOOL IVECO

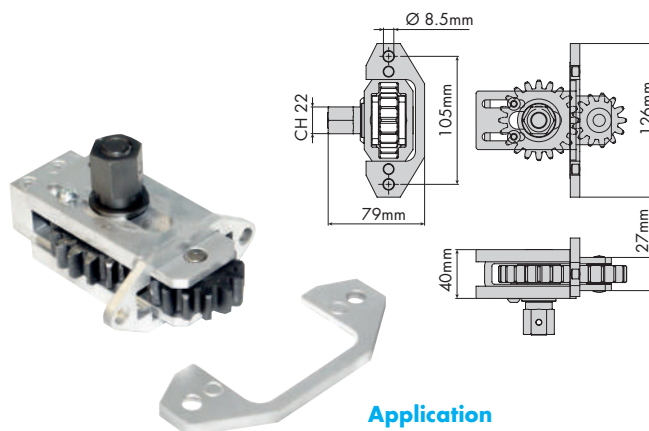

### Application

Euro Cargo, Cargo Eurotech  
Engine code: 8040-25-45, 8060-  
25-45, 8460, 8260, 8280,  
8210.42, 190.38, 190.42  
Heavyon, Off Road/Bus

**GO** CODE **1301**  
1 with 2 pcs. 1,6 kg

### Technical data

- 2 gears

## FLYWHEEL ROTATION TOOL MERCEDES

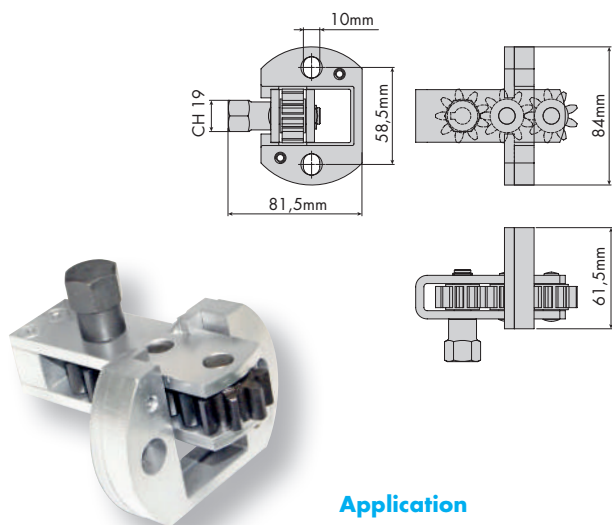

### Application

Mercedes: Actros, Atego

**GO** CODE **1302**  
1 with 1 pcs. 0,7 kg

### Technical data

- 3 gears

## FLYWHEEL ROTATION TOOL MERCEDES

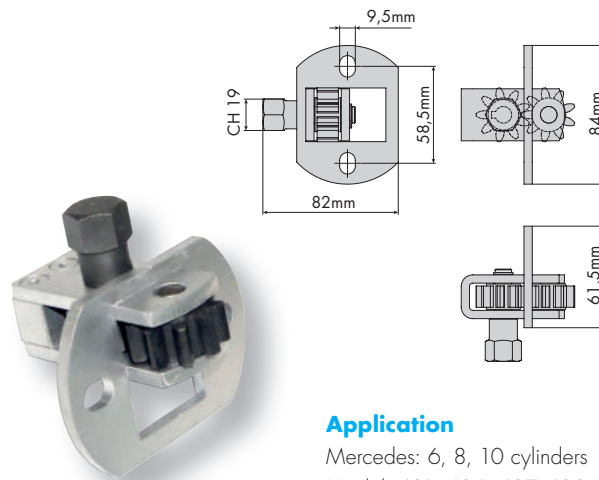

### Application

Mercedes: 6, 8, 10 cylinders  
Model: 401, 404, 407, 409 H/  
HA, 421, 424, 441, 444 A/LA,  
427, 429, 4289, 447 H/HA

**GO** CODE **1303**  
1 with 1 pcs. 0,6 kg

### Technical data

- 2 gears

## FLYWHEEL ROTATION TOOL RENAULT

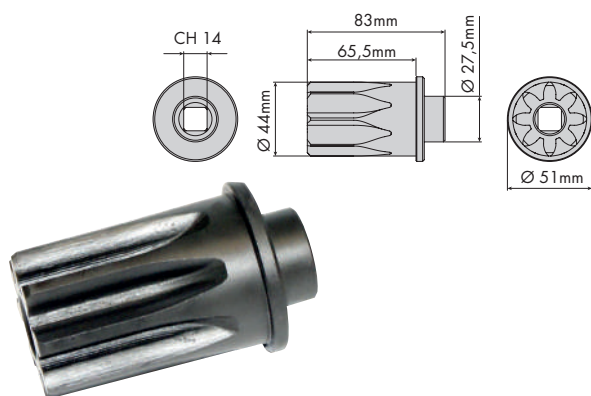

- Tool for engine flywheel rotation during the tappets adjustment.

### Application

Renault: Magnum

### Technical data

- Square 1/2"

**GO** CODE **1304**  
 1 with 1 pcs. **kg** 0,6 kg

## FLYWHEEL ROTATION TOOL RENAULT VOLVO

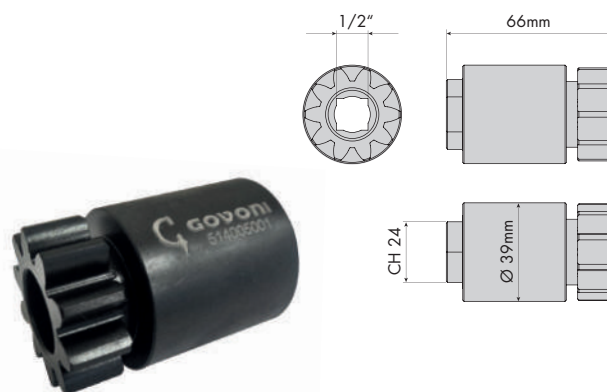

### Application

Brands: Renault, Volvo D13

### Technical data

- Square 1/2"

**GO** CODE **1305**  
 1 with 1 pcs. **kg** 0,6 kg

## FLYWHEEL ROTATION TOOL VOLVO

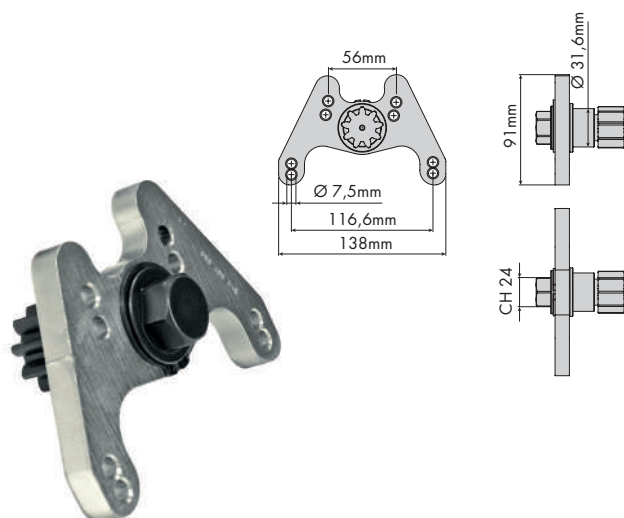

### Application

Volvo: 420, 460

### Technical data

- 1 gear

**GO** CODE **1306**  
 1 with 1 pcs. **kg** 1 kg

## FLYWHEEL ROTATION TOOL VOLVO

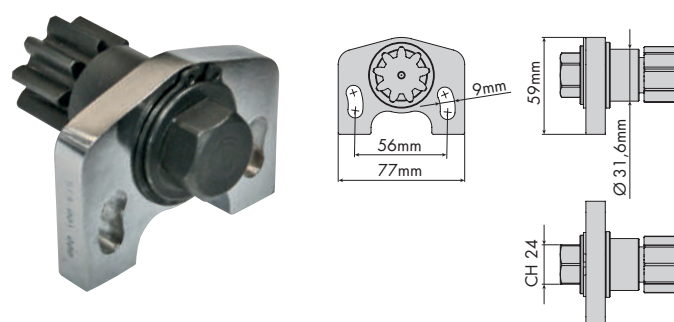

- Gear for engine flywheel rotation during the timing search.

### Technical data

- 1 gear

**GO** CODE **1307**  
 1 with 1 pcs. **kg** 0,7 kg



## DIESEL INJECTOR SEAL EXTRACTOR TRUCK - Ø10 MM



- Tool for the removal of the copper washer (placed on the bottom of the injector seat) post removal of diesel injectors.
- For easily and safely removal of copper washers glued on the bottom of the injector seat. Integrated slide hammer.



### Technical data

- For washers with holes Ø10 mm.
- Operation with a striking hammer of 0,5 kg.

<b>GO</b>	CODE	<b>511</b>
<b>1</b>	with 1 pcs.	<b>kg</b> 0,8 kg





## TORX SLOGGING BRAKE CALIPER WRENCH TRUCK



- They allow for the assembly/disassembly of the brake caliper fixing screws when working on the braking system.
- Used mainly on the front and rear axles of heavy vehicles.
- Even the most stubborn screws are released with the blow of a hammer on the end of the wrench.
- All wrenches are equipped with a  $\frac{3}{4}$ " square drive that also allows clamping, in combination with a torque wrench, according to the manufacturer's instructions.
- **Warning:** pay attention to the torque conversion formula marked on the wrench by means of a laser (necessary because of the lever's extension due to the type of construction).
- It is no longer necessary to remove the lever of the steering control tie rod.



**E18**



**Application**  
 MAN TGM - TGL etc.

**Technical data**  
 • Length: 220 mm

**GO** CODE **1311**  
 1 with 1 pcs. **kg** 0,6 kg

**E20**

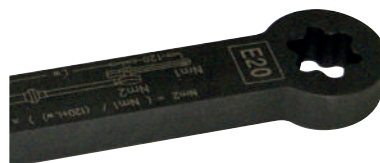

**Application**  
 MAN TGM, TGL/MB Atego  
 up to 9 ton etc.

**Technical data**  
 • Length: 220 mm

**GO** CODE **1312**  
 1 with 1 pcs. **kg** 0,6 kg

**E24**

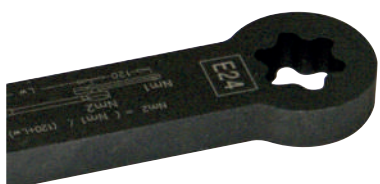

**Application**  
 MAN TGA, TGS, TGX/MB  
 Atego from 12 ton, Actros

**Technical data**  
 • Length: 220 mm

**GO** CODE **1313**  
 1 with 1 pcs. **kg** 0,6 kg

**M24**

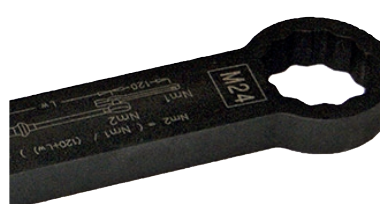

**Application**  
 MB Atego/Actros, SAF

**Technical data**  
 • Length: 220 mm  
 • 12-side profile

**GO** CODE **1314**  
 1 with 1 pcs. **kg** 0,6 kg

**M26**

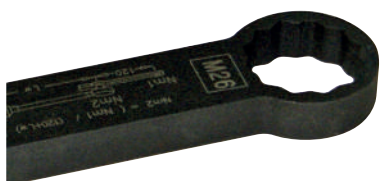

**Application**  
 DAF XF95/XF105/XF106/XF

**Technical data**  
 • Length: 220 mm  
 • 12-side profile

**GO** CODE **1315**  
 1 with 1 pcs. **kg** 0,6 kg

**M22**



**Application**  
 MAN TGL

**Technical data**  
 • Length: 220 mm  
 • 6-side profile

**GO** CODE **1316**  
 1 with 1 pcs. **kg** 0,6 kg

**M27**

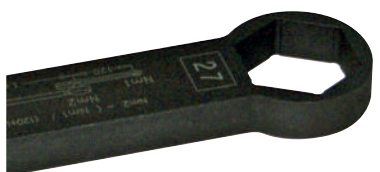

**Application**  
 MB Atego, Actros/Kässbohrer  
 Bus

**Technical data**  
 • Length: 220 mm  
 • 6-side profile

**GO** CODE **1317**  
 1 with 1 pcs. **kg** 0,6 kg

**M30**

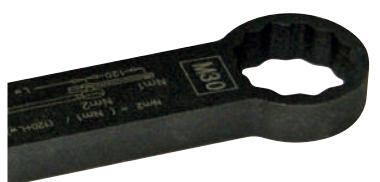

**Application**  
 Scania

**Technical data**  
 • Length: 220 mm  
 • 12-side profile

**GO** CODE **1353**  
 1 with 1 pcs. **kg** 0,6 kg

**GOVONI RANGE**

Code	Type	Profile	Application	Weight	Length	Picture
<b>GO1311</b>	E18	TORX	MAN TGM - TGL ecc.	0,6 kg	220 mm	
<b>GO1312</b>	E20	TORX	MAN TGM, TGL/MB Atego fino a 9 ton ecc.	0,6 kg	220 mm	
<b>GO1313</b>	E24	TORX	MAN TGA, TGS, TGX/MB Atego da 12 ton, Actros	0,6 kg	220 mm	
<b>GO1314</b>	M24	POLYGONAL	MB Atego/Actros, SAF	0,6 kg	220 mm	
<b>GO1315</b>	M26	POLYGONAL	DAF XF95/XF105/XF106/XF	0,6 kg	220 mm	
<b>GO1316</b>	M22	HEXAGONAL	MAN TGL	0,6 kg	220 mm	
<b>GO1317</b>	M27	HEXAGONAL	MB Atego, Actros/Kässbohrer Bus	0,6 kg	220 mm	
<b>GO1353</b>	M30	POLYGONAL	Scania	0,6 kg	220 mm	

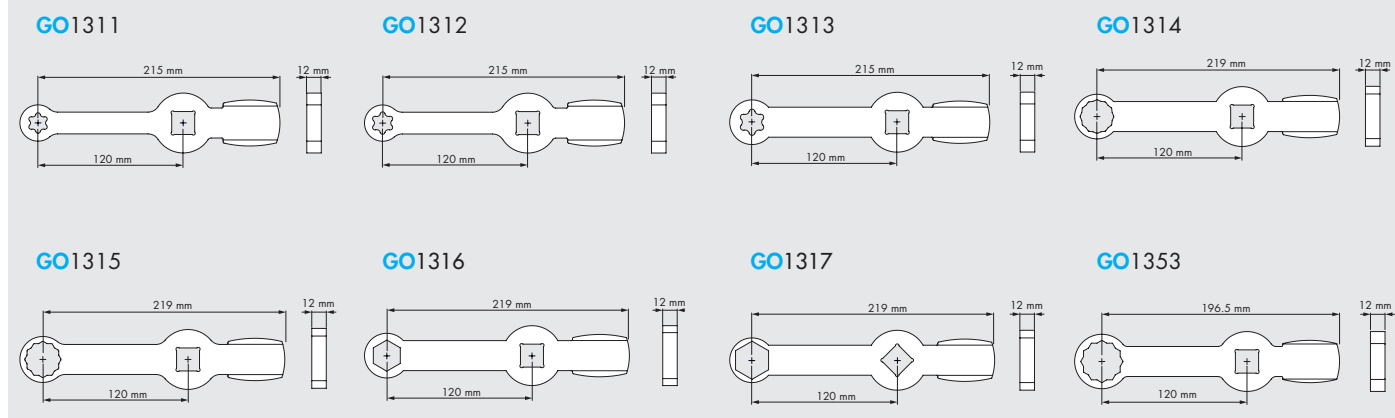

GO010.....	2	GO353.....	28	GO451.....	86	GO539.....	88	
GO011.....	3	GO354.....	28	GO452.....	87	GO540.....	89	
GO013.....	5	GO355.....	47	GO453.....	85	GO543.....	61	
GO015.....	9	GO356.....	41	GO454.....	71	GO559.....	61	
GO016.....	10, 188	GO357.....	41	GO455.....	72	GO560.....	66	
GO018.....	11	GO359.....	42	GO456.....	74	GO561.....	66	
GO019.....	12	GO361.....	40	GO457.....	75	GO562.....	65	
GO021.....	14	GO362.....	41	GO458.....	75	GO563.....	65	
GO022.....	14	GO363.....	29	NEW	GO459.....	75	GO564.....	65
GO025.....	15	GO364.....	29	NEW	GO464.....	76	GO601.....	129
GO030.....	16	GO366.....	45	GO469.....	72	GO602.....	129	
GO031.....	18	GO368.....	23	NEW	GO470.....	90	GO603.....	129
GO032.....	22	GO369.....	23	NEW	GO471.....	91	GO604.....	129
GO033.....	22	GO370.....	39	GO472.....	91	GO605.....	127	
GO034.....	22	GO371.....	38	GO473.....	91	GO612.....	118	
GO035.....	22	GO372.....	29	NEW	GO474.....	91	GO616.....	117
GO036.....	22	GO380.....	27	GO479.....	76	GO617.....	129	
GO038.....	49	GO384.....	44	GO484.....	77	GO619.....	99	
GO039.....	22	GO390.....	50, 160	NEW	GO489.....	92	GO620.....	120
GO041.....	10, 188	GO402.....	59	GO490.....	55	GO621.....	122	
GO045.....	24	GO403.....	63	GO491.....	75	GO622.....	120	
GO049.....	13	GO405.....	52	GO492.....	76	GO623.....	120	
GO055.....	21	NEW	GO406.....	71	GO493.....	74	GO624.....	126
GO054.....	19	NEW	GO407.....	69	GO494.....	76	GO625.....	126
GO060.....	8	GO411.....	74	GO499.....	92	GO626.....	120	
GO065.....	6	GO414.....	54	GO507.....	62	GO627.....	125	
GO068.....	112	GO415.....	81	GO509.....	92	GO628.....	126	
GO069.....	113	GO421.....	54	GO510.....	82	GO629.....	120	
GO070.....	4	GO423.....	72	GO511.....	218	GO630.....	126	
GO071.....	4	GO424.....	72	GO512.....	83	GO631.....	123	
GO072.....	4	GO425.....	60	GO513.....	83	GO632.....	124	
GO073.....	4	GO427.....	73	GO515.....	57	GO633.....	124	
GO074.....	4	GO428.....	78	GO516.....	78	GO634.....	123	
GO076.....	100	GO429.....	78	GO517.....	74	GO635.....	123	
GO077.....	133	NEW	GO430.....	78	GO519.....	73	GO638.....	116
GO100.....	30	GO431.....	78	GO520.....	25, 67, 201	GO639.....	116	
GO105.....	32	GO432.....	78	GO521.....	26	GO640.....	143	
GO110.....	33	GO434.....	64	GO522.....	26, 68	GO641.....	99	
GO115.....	31, 34	GO437.....	77	GO523.....	26, 68	GO643.....	123	
GO120.....	35	GO438.....	70	GO524.....	26, 68	GO644.....	123	
GO130.....	35	GO439.....	70	GO525.....	26, 68	GO645.....	100	
GO140.....	36	GO441.....	61	GO526.....	202	GO646.....	143	
GO142.....	36	NEW	GO442.....	72	GO528.....	202	GO647.....	144
GO314.....	41	NEW	GO443.....	72	GO530.....	25, 67, 201	GO648.....	142
GO316.....	45	GO444.....	72	GO532.....	66	GO649.....	142	
GO340.....	43	GO445.....	82	GO533.....	57	GO650.....	141	
GO345.....	44	GO446.....	82	GO535.....	140	GO652.....	122	
GO350.....	46	GO447.....	82	GO536.....	128	GO653.....	126	
GO351.....	28	GO448.....	82	GO537.....	58	GO654.....	121	
GO352.....	28	GO449.....	62	GO538.....	79	GO655.....	125	



GO656.....	121	GO711.....	178	GO761.....	163	GO816.....	175
GO657.....	121	GO712.....	161	GO762.....	181	GO817.....	174
GO658.....	122	GO713.....	149	GO764.....	159	GO819.....	174
GO659.....	120	GO714.....	181	GO765.....	171	GO820.....	162
GO660.....	117	GO715.....	179	GO766.....	167	GO821.....	166
GO661.....	121	<b>NEW</b> GO716.....	181	GO767.....	178	GO822.....	176
GO662.....	119	GO717.....	179	GO768.....	174	GO824.....	96
GO663.....	125	GO718.....	180	GO769.....	150	GO825.....	96
GO664.....	125	GO719.....	170	GO770.....	162	<b>NEW</b> GO826.....	158
GO665.....	122	GO720.....	168	GO771.....	160	<b>NEW</b> GO827.....	98
GO667.....	122	GO721.....	170	GO772.....	157	GO828.....	102
GO669.....	118	GO722.....	159	GO773.....	50,160	<b>NEW</b> GO829.....	3
GO670.....	122	GO723.....	150	GO774.....	175	GO830.....	168
GO672.....	125	GO724.....	153	GO775.....	167	GO831.....	169
GO673.....	121	GO725.....	171	GO777.....	154	GO832.....	97
GO674.....	126	GO726.....	158	GO778.....	163	GO833.....	169
GO675.....	123	GO727.....	172	GO779.....	164	GO853.....	165
GO676.....	127	GO728.....	166	GO780.....	157	GO854.....	165
GO677.....	128	GO729.....	162	GO781.....	170	GO855.....	150
GO678.....	121	GO730.....	165	GO782.....	166	GO858.....	98
GO679.....	125	GO731.....	151	GO783.....	178	GO859.....	154
GO680.....	124	GO732.....	166	GO784.....	177	GO860.....	159
GO681.....	127	GO733.....	173	GO785.....	180	GO861.....	153
GO682.....	124	GO734.....	162	GO786.....	154	GO863.....	165
GO683.....	137	<b>NEW</b> GO735.....	155	GO789.....	167	GO864.....	163
GO684.....	127	GO736.....	155	GO791.....	114	GO865.....	153
GO685.....	134	GO737.....	149	GO792.....	151	GO866.....	168
GO687.....	98	GO738.....	156	GO793.....	151	GO867.....	153
GO688.....	130	GO739.....	167	GO794.....	161	GO869.....	163
GO690.....	103	GO740.....	173	GO795.....	151	GO870.....	154
GO691.....	103	GO741.....	160	GO796.....	137	<b>NEW</b> GO871.....	169
GO692.....	137	<b>NEW</b> GO742.....	152	GO797.....	114	GO872.....	159
GO693.....	102	GO743.....	152	GO798.....	115	GO873.....	164
GO694.....	137	GO744.....	149	GO799.....	115	GO874.....	168
GO695.....	137	GO745.....	177	GO800.....	136	<b>NEW</b> GO875.....	156
GO696.....	142	GO746.....	161	GO800-X.....	136	<b>NEW</b> GO876.....	158
GO697.....	96	GO747.....	152	GO801.....	24	GO878.....	164
GO698.....	135	GO748.....	179	GO802.....	24	GO879.....	164
GO699.....	135	GO749.....	161	GO803.....	115	GO881.....	174
GO700.....	134	GO750.....	172	GO804.....	113	GO882.....	169
GO701.....	150	GO751.....	180	GO805.....	101	GO883.....	171
GO702.....	157	GO752.....	156	GO806.....	132	GO884.....	171
GO703.....	157	GO753.....	177	GO807.....	132	GO885.....	170
GO704.....	177	GO754.....	155	GO808.....	131	GO900.....	104
GO705.....	180	GO755.....	176	GO809.....	101	GO901.....	105
GO706.....	149	GO756.....	154	GO810.....	131	GO902.....	106
GO707.....	172	GO757.....	176	GO811.....	98	GO904.....	109
GO708.....	179	GO758.....	156	GO812.....	158	GO905.....	110
GO709.....	172	GO759.....	178	GO814.....	175	GO907.....	107
GO710.....	152	GO760.....	155	GO815.....	175	GO909.....	110

GO910.....	94		GO1060Q.....	186		GO1320.....	212
GO912.....	93		GO1061.....	187		GO1321.....	210
GO915.....	94		GO1061Q.....	187		GO1322.....	212
GO916.....	133		GO1062.....	187		GO1323.....	215
GO918.....	77		GO1062Q.....	187		GO1324.....	215
GO919.....	133		GO1070.....	188		GO1325.....	213
GO920.....	94		GO1070Q.....	188		GO1326.....	211
GO924.....	95		GO1110.....	84		GO1327.....	211
GO925.....	111		GO1111.....	84		GO1328.....	211
GO945.....	95		GO1112.....	84		GO1329.....	213
GO948.....	23	<b>NEW</b>	GO1127.....	199		GO1330.....	210
GO950.....	146		GO1145.....	202		GO1331.....	210
GO954.....	146		GO1146.....	202		GO1332.....	215
GO955.....	145		GO1147.....	203		GO1333.....	213
GO956.....	138		GO1148.....	203		GO1334.....	212
GO957.....	138		GO1151.....	199		GO1335.....	211
GO958.....	138		GO1152.....	198		GO1336.....	211
GO959.....	138		GO1153.....	198		GO1337.....	212
GO960.....	147		GO1155.....	203		GO1338.....	212
GO961.....	139	<b>NEW</b>	GO1174.....	200	<b>NEW</b>	GO1339.....	211
GO962.....	139	<b>NEW</b>	GO1175.....	195		GO1340.....	212
GO963.....	139	<b>NEW</b>	GO1176.....	194		GO1341.....	214
GO964.....	139	<b>NEW</b>	GO1177.....	194		GO1342.....	214
GO965.....	139	<b>NEW</b>	GO1178.....	197		GO1343.....	214
GO970.....	147		GO1179.....	197		GO1344.....	213
GO975.....	145		GO1190.....	196		GO1345.....	214
GO1010.....	185		GO1191.....	196		GO1346.....	214
GO1012.....	186		GO1192.....	196		GO1347.....	213
GO1012Q.....	186		GO1193.....	196		GO1349.....	214
GO1014.....	184	<b>NEW</b>	GO1195.....	197		GO1350.....	213
GO1015.....	185		GO1199.....	200	<b>NEW</b>	GO1351.....	215
GO1016.....	184		GO1300.....	216		GO1352.....	215
GO1017.....	187		GO1301.....	216		GO1353.....	220
GO1017Q.....	187		GO1302.....	216		GO1354.....	209
GO1018.....	187		GO1303.....	216		GO1355.....	208
GO1018Q.....	187		GO1304.....	217		GO1356.....	215
GO1020.....	188		GO1305.....	217		GO1366.....	48
GO1020Q.....	188		GO1306.....	217		GO1401.....	205
GO1030.....	189		GO1307.....	217		GO1402.....	205
GO1030Q.....	189		GO1308.....	210		GO1403.....	205
GO1031Q.....	191		GO1309.....	210			
GO1032.....	188		GO1310.....	209			
GO1032Q.....	188		GO1311.....	220			
GO1033.....	191		GO1312.....	220			
GO1033Q.....	191		GO1313.....	220			
GO1040.....	190		GO1314.....	220			
GO1040Q.....	190		GO1315.....	220			
GO1050.....	186		GO1316.....	220			
GO1050Q.....	186		GO1317.....	220			
GO1060.....	186		GO1319.....	210			

THE**TOOL**MAKER.COM

# THE**TOOL**MAKER.COM

the toolmaker  
**GOVONI**<sup>®</sup>

Via degli Orsi, n. 97  
40014 Loc. Beni Comunali  
Crevalcore (BO) | Italy  
+39.051.982688  
+39.051.980798  
info@govoni.it

